

# TRANSMITTING TOPICS

See Page 400



# Practical and Amateur Wireless

Edited by F. J. CAMM

Technical Staff:  
W. J. Delaney, H. J. Barton Chapple, Wh.Sch.,  
B.Sc., A.M.I.E.E., Frank Preston.

Vol. XIV, No. 355. July 8th, 1939.

## ROUND *the* WORLD *of* WIRELESS

### The 1939 Superhet

IT is doubtful if any type of receiver has received the popularity which has been gained by the superhet, and in spite of its many short-comings, it still holds the position of the ideal home-broadcast receiver. It is, of course, possible to make a superhet with only two valves, whilst at the other extreme as many as fifteen valves may be usefully employed in a superhet circuit. With the superhet go such refinements as variable selectivity; automatic-volume control in many forms; visual tuning indication, and similar arrangements. Many of these have been introduced of necessity due to the characteristics of the superhet arrangement, but others are advantages which are best seen in a receiver in which this feature is employed. In this issue we describe the construction of a seven-valve superhet (including rectifier) in which certain of these features may be seen, and a push-pull stage is incorporated so that really good quality at high power may be obtained. The receiver is economical to construct and maintain, and is not difficult to build. Many of the difficulties of construction in a superhet are found on the H.F. side, where a number of coils and switches have to be wired, but in the 1939 Superhet this has been avoided by using a commercial tuning pack. This incorporates the coils, switches and condensers, and thus the wiring operations are reduced, and higher efficiency may be expected. Full constructional details will be found on pages 396-398.

### Aerial Service Area

THE design of the transmitting aerial controls the useful service area, and wide claims are made for a new type of aerial which has been tried out at the Stolp relay station in Germany. It is claimed that a useful increase of 20 per cent. has been obtained during the hours of darkness by the new aerial which is supported on a circle of six masts at a height of 150ft.

### Radio Tunis

THE reconstructed station at Radio Tunis is practically ready for tests and it is anticipated that the station will be put into operation by the end of September. The power of the new station will be 120 kW.

### R.M.A. Television Service Area Map

A MAP showing the area in which reliable reception can be obtained from the Alexandra Palace television station has just been compiled by the R.M.A. from exhaustive information supplied by television receiver manufacturers' members.

The map, which measures approximately 31in. by 28in. is in three colours, shows all the important towns inside the service area, and includes county boundaries and the names of the counties.

It proves that, if it is desired to quote a round figure for the effective radius of the station, a figure of 40 miles can safely be used.

It is, of course, impossible to lay down a hard and fast line between the area where reception is satisfactory and that where it is unsatisfactory, so the outer boundary has been indicated by a broad shading covering an area roughly five miles wide.

Copies are available to anyone who is interested from the Radio Manufacturers' Association, 59, Russell Square, London, W.C.1, at 2s. 6d. each.

### ON OTHER PAGES

	Page
A Simple Remote Control	387
Car-radio Experiments—2.	389
On Your Wavelength	391
Short-wave Section	393
Readers' Wrinkles	395
The 1939 All-wave Superhet	396
Practical Television	399
Transmitting Topics	400
Relays and 'Phone Broadcasting	402
Readers' Letters	404
Queries and Enquiries	407

### New Air Station

THE Air Ministry have brought into operation a new station at Belfast Harbour, with the call sign GVE. This station operates on 857 metres (350 kc/s), and acts as the area station in place of Newtownards—which, in future, will be a collaborating station.

### German Radio Exhibition

THE Berlin Radio Show, which opens on July 28th, will again feature television apparatus, although apparatus previously exhibited has not yet been put into regular service. Worldwide propaganda for the show is in hand, and among the features will be a "Children's Broadcasting Corner," and sports in the garden.

### No Relay For Grimsby

AS a result of a deputation from the Grimsby Chamber of Trade and other local associations, the town's Highways Committee have decided not to consider an application for a relay service in Grimsby.

### New B.B.C. Service

ON July 3rd a new early morning service was inaugurated by the B.B.C. for Latin-American listeners. The programme is scheduled for 12.25 to 2.15 a.m.

### Licence Figures

THE total number of receiving licences in force at the end of May in Great Britain was approximately 8,984,250. This represents a rise which was not in evidence at the same period of last year.

### "Where's That Tiger?"

THE village of Ballymakillop was sinking into oblivion until Sarah McWhittrick saw a tiger in her hen-pen, and then its name splashed into the headlines of civilisation. Wires buzzed, telephones rang, planes zoomed across the Channel, and questions were fired off in the Commons. And while Ballymakillopians gasped "Where's that Tiger?" Sergeant Fogarty swore: "Oi'm a policeman, Oi am—not a big game hunter!" The Police Force and the Army caught it in the end—and then the world laughed! But, anyway, sleepy Ballymakillop lived its "short fierce hour and sweet." Those who listen to this half-hour frolic, the work of a Belfast journalist, to be broadcast on July 8th, will hear what happened when they caught the tiger.

# ROUND the WORLD of WIRELESS (Continued)

## The Revival of the Roman Era

THE privately owned transmitter, Radio Tunis, on 215 m. (1,395 kc/s), has now been re-named Radio Carthage. This 1-kilowatt station broadcasts daily from B.S.T. 12.00-14.00 and from 20.15-23.00.

## British Esperanto Listener Guest of Italian Authorities

MR. P. A. RODGERS, a young Esperantist of Darlington, returned to England on June 11th from a free holiday in Italy, which he gained as a prize through taking part in a wireless competition in Esperanto from the Rome stations. The award consisted of free second-class rail facilities and hotel accommodation for visits to Rome, Turin, Capri, Pompeii and Ostia. Throughout he received the utmost cordiality and friendship from Italian Esperantists and the authorities.

## Radio Bizerta

IN addition to the broadcasting station at Tunis, the French authorities also possess a small 100-watt transmitter at Bizerta. This station, which operates on 209 m. (1,435 kc/s), is on the ether every day between B.S.T. 12.30-15.30; and from 21.30-23.30.

## "Review of Revues"

FROM Midland shows which he has produced in the past, Martyn C. Webster has picked some of the gayest tunes for a broadcast under the title "Review of Revues," to be heard on July 7th. Reginald Burston will conduct the Midland Revue Orchestra, and the vocalists will include Marjery Wyn. Mr. Webster will return to Birmingham at the end of June after spending three months at Manchester as producer of light entertainment programmes in the North Region.

## Dance Cabaret from Torquay

DANCE Cabaret will be broadcast from the Grand Hotel, Torquay, on July 6th in the National programme.

## "My Week-end"

SHORT accounts by various people telling how they will spend the week-end out of doors and where they are going to spend it, will be broadcast fortnightly under the title, "My Week-end." The first of these broadcasts will be given in the Western programme on July 7th.

## Scarborough on the Air

SCARBOROUGH will be on the air twice during the evening of July 7th, when Northern listeners will hear Reg. Williams and his Futurists playing the Spa ballroom at the Yorkshire resort, sharing this pro-

## INTERESTING and TOPICAL NEWS and NOTES

gramme period with Larry Hall and his band, who will be playing in the Manchester studios. Later in the evening, for Regional as well as Northern listeners, Murray Ashford's "The Bouquets," a well-known Northern concert-party, which has often broadcast in the past, will be heard, also from the Spa at Scarborough.

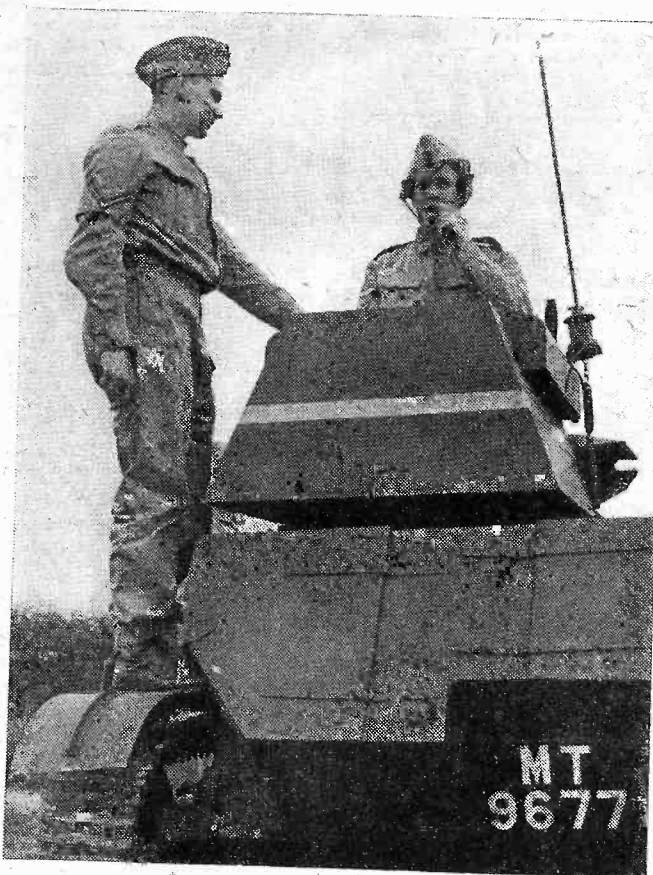

The Cambridge University Officers Training Corps recently had their voluntary camp at Cambridge. When the War Office cancelled all official O.T.C. camps last year, Cambridge decided to hold its activities on its own Rifle Range at Cambridge. Our illustration shows a tank in radio communication with headquarters at the camp.

## Dance Band from Liverpool

ADMIRERS of Jack McCormick and his Ambassadors, the band which plays at the Rialto Ballroom, Liverpool, will be interested to know that this combination is to have a half-hour broadcast on the Northern wavelength on Thursday evening, July 13th, direct from the ballroom.

## "New Brighton Night"

VICTOR SMYTHE is producing a "New Brighton Night" feature on July 6th, with broadcasts from the resort's Tower Ballroom, where the Playboys Dance Band will be heard: Frank A. Terry's show, "Pleasure on Parade," at the Floral Pavilion; and the variety bill at the Tivoli Theatre.

## The Royal Welch Fusiliers

THE Royal Welch Fusiliers is one of the oldest Regiments in the British Army. This year it celebrates the two

hundred and fiftieth anniversary of its foundation. This will be done in fitting style at Caernarvon Castle on August 5th, and in preparation for this event the microphone will visit the depot at Wrexham on July 7th for a sound picture of the Regiment's life in barracks.

## "Cabarette"

ON July 6th the artists in "Cabarette," presented by Leslie Bridgmont, will be Doreen Pullen (impressions), Compton Evans and Ray Monelle (in original songs at the piano), and Ruby Taylor and Frances Keyte (four hands and two pianos).

## Opera from Glyndebourne

THE whole of Verdi's "Macbeth" will be broadcast from Glyndebourne on July 7th, with the following soloists: Francesco Valentino, Margherita Grandi, David Franklin, David Lloyd and Eric Starling. Listeners will hear Acts I, III and IV in the National programme and Act II in the Regional.

## A Civil Air Guard on Gliding

TERENCE HORSLEY, a journalist who has broadcast several times from the North-East and has helped to arrange one or two programmes that have come from this part of the world, has joined the Civil Air Guard, and on the evening of July 10th he will present a short programme on flying, but on gliding in particular. He will bring to the microphone others concerned with this increasingly-popular sport, a thorough grounding in which provides a valuable basis for the training of potential aeroplane pilots. Horsley, who studied gliding closely before he returned as a newspaper man to Newcastle-on-Tyne, has broadcast on the subject before, describing Great Hucklow "meets" from the Manchester studios.

## SOLVE THIS!

### Problem No. 355

JACKSON was building an A.C. receiver in which was an H.F. pentode. The maker's instructions said that the screen should be supplied from a potentiometer consuming a greater current than the screen and therefore Jackson selected two suitable resistors, which he joined between H.T. positive and negative, with the screen taken to the junction. When tested the resistors got very hot, and he decided that the current was excessive. As results were good he decided that the H.T. on the screen was in order and to avoid altering this, but to reduce the current, he decided to add a resistance in series with that on the earth side of the screen. He did this, and although the resistances did not heat up, results were not so good. Why was this? Three books will be awarded for the first three correct solutions opened. Entries must be addressed to The Editor, PRACTICAL AND AMATEUR WIRELESS, Tower House, Southampton Street, Strand, London, W.C.2. Envelopes must be marked Problem No. 355 in the top left-hand corner and must be posted to reach this office not later than the first post on Monday, July 10th, 1939.

### Solution to Problem No. 354

When Matthews connected his receiver to the D.C. supply he overlooked the fact that one pole is positive and that therefore the mains plug has to be inserted in correct relation to the supply. Each time he inserted his plug he had it reversed and the receiver accordingly failed to work.

The following three readers successfully solved Problem No. 353, and books have accordingly been forwarded to them: J. Robertson, Aukengill, Wick, Caithness; J. R. James, Bank House, 46, Stafford Road, Wallington; G. Butler, 41, Station Road, Handsworth, Birmingham, 21.

# A Simple Remote Control

*How to Provide Full Control of a Receiver by a Push-button Unit Situated at a Distance from the Receiver*

RECENT developments in radio receiver design have been responsible for the introduction of many forms of automatic-tuning systems, by means of which a radio receiver may be tuned in to one or other of a number of predetermined stations simply by pressing a selected one of a number of press buttons representing the desired stations. In one system the tuning condenser of the receiver is coupled to an electric motor, and the press buttons control switches in a control network for the motor, so arranged that actuation of any one press button will cause the motor to move the tuning condenser to a predetermined station-selecting position. In another system the press buttons actuate switches, each one of which connects a selected one of a number of pre-tuned circuits into the circuit of the receiver, and in other systems the press buttons actuate switches which introduce pre-tuned coils or condensers of different values into the circuit of the receiver.

The use of press buttons is not, of course, limited to the selection of predetermined stations or frequencies; they may also be used for waveband selection and for other functions, such as volume control and frequency control.

Usually the press buttons are mounted on the receiver, but it is often desirable to be able to control the receiver automatically from one or more remote points. When a motor-operated tuning system is employed, this may be accomplished by arranging the press-button switches in a separate box or case and coupling them to the circuits of the motor by means of leads, such as a multi-core flexible cable. In other cases a duplicate set of press-button switches may be provided at the remote point and each switch is connected by leads in parallel with its corresponding press-button switch at the receiver, whereby the motor may be operated by actuation of either a local press button or a press button situated at the remote point, to tune the receiver to a desired predetermined station.

In either case it is necessary to provide at least one more lead than there are press buttons, and the cost of the multi-core cable becomes heavy if the number of press buttons is large and/or the run for the cable is long.

The provision of remote control when the switches controlled by the press buttons are included in the circuits of the amplifier of the receiver, such as in the pre-tuned circuit and like kinds of tuning systems, presents difficulties. The difficulties may be overcome by providing remote-control apparatus which will in effect actuate a set of local press buttons at the receiver, and in this article is described a remote-control system in which a radio receiver is provided with local press buttons which may be actuated to control the receiver, and with a remote control unit comprising a duplicate set of press buttons and means for actuating the local press buttons under the control of the duplicate or remote set of press buttons.

The remote-control unit may comprise a single member which can be moved under control of the remote press buttons into engagement with any desired local press

button, and then moved to actuate the selected press button, or a separate actuating member may be associated with each local press button. An important feature of this remote control unit resides in the control by means of relays of the member or members which actuate the local press button. This results in a considerable reduction in the number of leads required for a given number of press buttons, and the system may thus often be used with advantage in preference to other systems for motor-tuned receivers.

## Magnetic Operation

Preferably, the push buttons at the receiver are actuated by electro-magnets which are selectively energised by the push buttons at the remote control device. Selective energisation of the electro-magnets may be effected through the medium of relays which themselves are energised by operation of the push buttons of the remote control device, the latter buttons serving to apply current in one of two directions, say, in a positive or negative direction to the relays.

The relays employed may be of the self-centring type, wherein when no potential is applied to the coil of the relay, the contacts of the relay are in their central position; when a positive potential is applied to the coil of the relay the contacts may be caused to move in one of two directions, say, in a left horizontal direction, while when a negative potential is applied to the coil of the relay the contacts may be caused to move in a direction opposite to the aforesaid direction. Each of these positions for each relay may be combined with each of the positions of the other relays employed. Thus, when two relays requiring only two leads are employed and each has three possible positions, the two relays provide nine possible combinations. One of these combinations, however, corresponds to the condition when no potential is applied to the coils of both relays, and, neglecting this combination, it is seen that two such relays provide eight effective combinations. In a similar manner, three such relays, requiring only three leads and each having three possible positions of their contacts, provide 26 effective combinations.

Reference should be made to the accompanying drawings which represent an embodiment of the idea by way of example and in which Fig. 1 illustrates on the left-hand side the connections made at the

push-button control remote from the radio receiver, and illustrates on the right-hand side coils situated at the receiver which serve to actuate relays. Fig. 2 illustrates the circuit connections at the receiver.

In Fig. 1 the push buttons situated remote from the receiver are indicated as being utilised for operating the receiver to "on" or "off," and the volume to "up" or "down," and with ten other push buttons numbered 1-10 for operating the receiver to tune it to the various transmitting stations or any other functions that may be desired. Each push button is connected to one or both of the rectifiers X and Y, X and Y being rectifiers situated at the remote control which rectify in opposite directions, and to one or more of the terminals A, B and C.

## Relay Working

When one of the push buttons is pressed it serves to complete circuits between the rectifiers X and Y and the terminals A, B and C. It will be observed from Fig. 1 that some of the push buttons are connected with a single pair of contacts which are closed when the push button is pressed, whilst other buttons are connected with two pairs of contacts both of which are closed when the

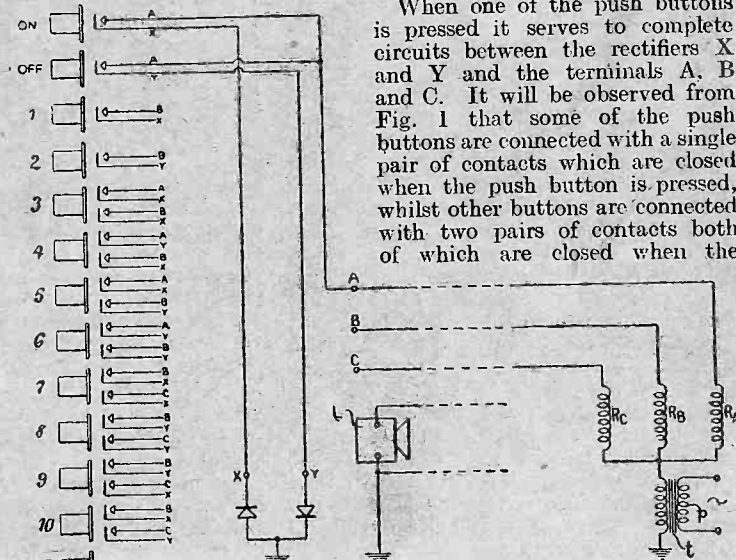

Fig. 1.—Practical arrangement of the Remote Control mechanism.

associated push button is depressed. The various contacts are lettered with combinations of the letters A, B, C, X and Y to indicate how the contacts are connected to the terminals A, B, C and to the rectifiers X and Y. Thus the button numbered 1 serves to complete a circuit between the rectifier X and the terminal B, while the button numbered 5 serves to connect terminal A with the rectifier X and terminal B with the rectifier Y. Leads run from the terminals A, B and C to the coils of the relays R<sub>A</sub>, R<sub>B</sub> and R<sub>C</sub> at the receiver, so that when one of the push buttons is operated, current flowing through either or both of the rectifiers X and Y is supplied to one or more of the relay coils R<sub>A</sub>, R<sub>B</sub> and R<sub>C</sub>. The rectifiers X and Y complete the circuits for the supply of potential to the coils R<sub>A</sub>, R<sub>B</sub> and R<sub>C</sub> of the relays when the push buttons shown to the left of Fig. 1 are depressed.

The source of the supply of potential for the coils R<sub>A</sub>, R<sub>B</sub> and R<sub>C</sub> is a transformer "t" shown to the right of Fig. 1 below the coils R<sub>A</sub>, R<sub>B</sub> and R<sub>C</sub>, and the primary of this transformer "p" is always connected

(Continued on next page)

## A SIMPLE REMOTE CONTROL

(Continued from previous page)

in circuit from, if necessary, a separate source of supply from that utilised for the radio receiver. This transformer "t" is connected in circuit during stand-by time and may be so constructed as to take an almost negligible amount of power, and it is so connected that on pressing the "on" button for the receiver the contacts of relay A are moved so as to complete the circuit for the primary of the transformer "t" which supplies the power for setting the radio receiver as is hereinafter explained.

The relay coils  $R_A$ ,  $R_B$  and  $R_C$  of Fig. 1 serve to actuate the movable contacts of the relays A, B and C of Fig. 2 respectively. Referring now to Fig. 2, current flowing through the rectifier X causes the contacts of the relays A, B and C to move to the left while current through the rectifier Y causes the contacts of these relays to move to the right.

The coils numbered 11 to 20 are energised from the source of alternating current potential indicated conventionally at 21, which is applied to the primary winding P of a transformer, T, the secondary winding 22 of which is connected to the coils numbered 11 to 20 through a rectifier 23. Whichever coil of the coils numbered 11 to 20 is energised depends upon the positions of the movable contacts of the relays A, B and C, and this in turn depends upon the potentials which are applied to the coils  $R_A$ ,  $R_B$  and  $R_C$  of the relays. For any of the electro-magnet coils numbered 11 to 20 to be energised it is necessary to complete the circuit through the electro-magnet coil from the rectifier 23 to earth. With the connections shown in Fig. 2, the coil 15 is energised when the contacts of the relay A are moved to the left and those of relay B are moved to the right, the circuits being completed through contacts  $A_5$  and  $B_1$ . To complete the circuits to the coil 15 the button 5 shown to the left of Fig. 1 is depressed and this causes the circuits to be completed to the coils  $R_A$  and  $R_B$ , these coils being supplied with current through the rectifiers X and Y respectively. The relay coil  $R_C$  is not energised thereby, so that the contacts  $C_1$  and  $C_5$  remain in the central position, shown in Fig. 2. As another example, for electro-magnet coil numbered 17 to be energised the button 7, shown to the left of Fig. 1, is depressed so that the coil  $R_C$  of relay C has applied thereto a current through the rectifier X, the circuit being made through contact  $C_2$  and the coil of relay B has applied thereto a current through the rectifier X, the circuit being completed through contact  $B_1$ . Thus, when any of the coils numbered 11 to 20 of the electro-magnets is energised by the remotely situated push buttons the corresponding push button located at the radio receiver is operated so that, in effect, the push buttons of the receiver are operated from a position remote from the receiver. In the means shown in connection with Figs. 1 and 2 this is effected by utilising only three leads from the remote press buttons to the relay coils situated at the receiver. A connection for earthing one side of each of the rectifiers X and Y is required and this earthing connection may be made at the remote point or a lead may be run from the rectifiers to the earth connection situated at the receiver. It is preferred to make the earth connection for the remote loudspeaker shown at L, Fig. 1, to the earth connection situated at the receiver.

## Switching "Off"

In order to switch on the radio receiver the button marked "on," shown to the left of Fig. 1, is pressed. This causes current through the rectifier X to flow through the relay coil  $R_A$  and thereby the contact  $A_1$  of relay A is moved to the left and completes a circuit through the primary coil of the transformer T shown in Fig. 2, from the source of supply 21 to earth. The current flowing through the primary coil P of transformer T energises the coil 24 of the rectifier 25 and the current through the coil 24 actuates a holding relay coil 26. This coil 26 serves to close contact 27, completing the circuit for the primary coil P of the transformer T independently of control  $A_1$ . Movement of contact 27 makes it unnecessary for contact  $A_1$  to remain in the left-hand position for energisation of the primary coil P and this contact  $A_1$  is hereby left free for further actuation by the source of potential X and Y. Further depression of any of the press buttons to the left of Fig. 1 supplying current through the rectifiers X or Y to the relay A causes contact  $A_1$  to move, the circuit from the primary coil of the transformer T still being completed through the contact 27.

It will be noted that only the "off" button shown to the left of Fig. 1 serves to short-circuit the holding relay coil 26 in Fig. 2. Depression of any other push button shown to the left of Fig. 1 serves to move the contacts of relay B either to the left or the right-hand position and thereby breaks the circuit for short-circuiting the holding coil 26 through contact  $B_2$  and contact  $A_1$  to earth.

In place of the electro-magnet coils of Fig. 2 which are utilised to operate the push button at the radio receiver a single electro-magnet may be used, this electro-magnet being brought opposite the required push button by the use of a selector drum. This selector drum may be in the form of a cylinder, having the single electro-magnet mounted on the periphery thereof and the amount of rotation of the cylinder may be made to depend upon the movement of the movable relay contacts which, in turn, depends upon the remote push button which is operated. The various amounts of rotation imparted to the cylinder may cause the electro-magnet to come opposite different press buttons situated at the receiver, the relay being arranged so that the electro-magnet is energised when the appropriate push button is opposite the

electro-magnet and the electro-magnet is de-energised when the required tuning function has been performed.

## Tuning Operations

The push buttons at the receiver may serve to effect tuning in any suitable manner. For example, they may switch into operation pre-tuned circuits or they may operate a motor for adjusting the tuning device of the receiver.

The lowermost push buttons to the left of Fig. 1 which are indicated as operating the receiver to cause the volume to increase and decrease respectively, cause currents through either the rectifier X or the rectifier Y to be applied to the coil of relay C. When current flowing through the rectifier X is applied to the relay coil  $R_C$  the movable contact  $C_1$  of relay C, Fig. 2, is moved to the left and the circuit

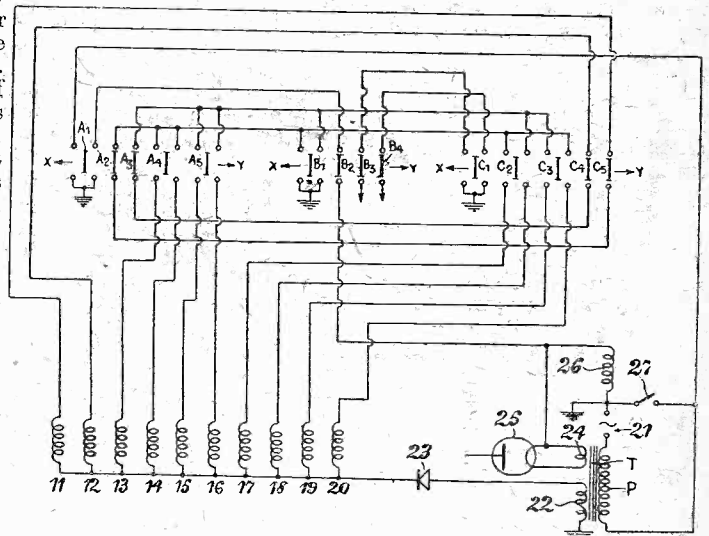

Fig. 2.—Theoretical circuit of the control mechanism.

is completed through contact  $B_3$ , while when current flowing through the rectifier Y is applied to the relay C the movable contact  $C_1$  is moved to the right and the circuit is completed to contacts  $B_4$ . From each of these contacts  $B_3$  and  $B_4$  a circuit is completed to actuate the volume control of the receiver; the circuit through contacts  $B_3$  serving to increase the volume output of the radio receiver and the circuit through contacts  $B_4$  serving to decrease the volume output of the radio receiver. The circuits from the contacts  $B_3$  and  $B_4$  may serve to operate a magnetic clutch of the motor so that the volume control spindle of the radio receiver is driven by the shaft of the motor, a circuit of which motor is completed from either of the contacts  $B_3$  or  $B_4$  to cause the volume control spindle to be driven in the required direction.

In one preferred arrangement, loudspeakers, which are employed at a position remote from the radio receiver and of which one is indicated at L in Fig. 1, are provided with volume controls which are situated adjacent to the loudspeakers. In order that such an arrangement may function properly an efficient system of automatic volume control is required to be embodied in the receiver, and a volume control is required across the loudspeaker at the receiver as well as at the remote positions. The difficulty of efficient automatic volume control and the expense thereby entailed may be practically overcome by causing the push button to operate a volume limiting device which is pre-set at the receiver according to the station which it is required to receive.

PLAN A CAMPING HOLIDAY WITH  
**NEWNES**  
**CAMPER'S HANDBOOK**

By David Balfour

Everything the camper wants to know

From all Booksellers 2/6, or  
by post 2/9 from the Publishers.GEORGE NEWNES, LTD. (Book Dept.), Tower  
House, Southampton Street, London, W.C.2.

# Car-radio Experiments—II

Continued from Last Week, this Article by FRANK PRESTON explains the Need for Suppressor Devices when Using an Improvised Car-radio Receiver

LAST week I dealt fairly briefly with some suitable forms of experimental car aeri-als. In addition to the roof and fishing-rod types, an illustration was given of an under-car V-type aerial, but shortage of space did not permit of a description of this aerial being given. The following brief particulars refer to the aerial shown on page 375 last week.

It is a V, with equal-length arms, the lead-in being taken from the apex. Ordinary aerial wire can be used, and it should be fitted with insulators, which can be attached to the ends of the axle case by binding with wire just outside the shock-absorber

relation to the design of the receiver, so the constructor cannot normally fit them with success.

### Extent of Suppression

Experiments soon show that the number and arrangement of suppressors are by no means standardised; sometimes only slight suppression is needed to remove interference entirely, whilst in other instances a considerable amount of care is taken. The design and layout of the ignition and electrical circuits of the car have a marked effect, but the effectiveness of the receiver screening is a factor which cannot be overlooked.

With most commercially-made receivers of modern design it is necessary only to include a suppressor resistor in the main high-tension lead to the centre of the ignition distributor and a condenser between terminal SW on the coil and earth. Special resistors are sold for the purpose, these having a bakelite shroud with shrouded push-in type connectors. For purely experimental purposes you can try an ordinary metallised or composition resistor of about 25,000 ohms, but it will be necessary to bind the ends with insulating tape. And since the proper

component is not expensive it is by far the best to buy one. In most cases it can be fitted simply by cutting the H.T. wire about 1in. above the distributor, when the two ends of the cut can be pressed into the ends of the resistor; sometimes there is a screw inside the end of the component, and then the wire ends should be screwed in position. Remember that the suppressor should be as close to the distributor as possible if it is to be fully effective.

An ordinary tubular condenser can be used for the coil, but this is not fully effective due to it being unscreened. A suitable value is about .25 mfd. A proper suppressor condenser in metal case is in every way to be preferred, and the bracket of this can be attached to any convenient engine, chassis or bulkhead screw near to the coil. The two essential suppressors are shown in Fig. 1, along with the method of fitting.

### Individual Plug Suppressors

When magneto ignition is employed it is clearly impossible to fit the main-H.T. suppressor, and in that case it is nearly always essential to include a resistor in each plug lead when using other than a carefully-designed special car-radio receiver. These resistors may have a value between 25,000 and 50,000 ohms, but here again, it is wise to use the special components which are supplied with terminal ends for directly fitting to the sparking-plugs and to the plug leads. These suppressors should be close to the plugs so that they are as near as possible to the actual spark gap—from which the interference is radiated.

There is a good deal of prejudice about the fitting of these resistors, but in few instances is it well founded. They do, of course, "slow-down" the spark to a slight degree, and it is by so doing that they prove effective. Except on a fairly highly-tuned engine, however, they seldom have any marked effect on either performance or fuel consumption. If it is believed that the behaviour of the engine is less satisfactory after the suppressors have been fitted, the effect of slightly reducing the sparking-plug gaps can be tried, except in those cases where special so-called wide-gap ignition is used.

It will sometimes be found that individual plug suppressors must be used in addition to the main H.T. component with coil ignition when there is no provision for suppression inside the set. The same remarks apply as when magneto ignition is fitted.

### Screened Ignition Leads

When wide-gap ignition is used (plug gaps set to between 25 and 45 thou.), or if it is feared that engine performance might suffer from the installation of individual plug resistors, it is frequently possible to obtain very satisfactory results by screening either the main H.T. lead or all leads carrying H.T. This can be done by using screened wire, taking care to keep the leads as short as possible and to earth the screening at not less than two points, or by passing all the leads through a metal tube with side holes through which the ends of the leads can be fed to the plugs. The tube can be attached to the cylinder-head studs by means of short brackets. See that the tube is sufficiently far above the cylinder head for the leads not to become unduly hot. With an o.h.v. engine the tube can generally be fitted to convenient

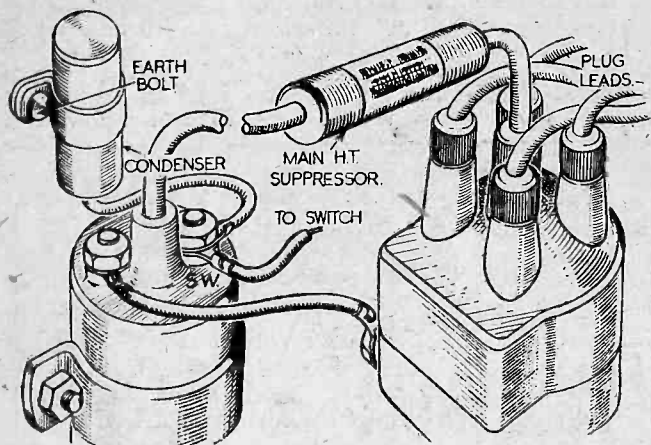

Fig. 1.—Connection for a main H.T. suppressor resistor and an ignition-suppressor condenser.

brackets. An insulator is also required at the forward end, and this should be fitted to the gearbox through a small spring which is in light tension; this allows for the movement of the rear axle.

If there is not a convenient gearbox bolt, a thin iron plate with large hole can sometimes be fitted under the flange of the drain plug. Take care, however, that the fibre washer is replaced on the plug and that the plate is flat and not more than 1-16in. thick. When the aerial would foul the chassis if attached directly to the gearbox it is not usually difficult to use a small iron bracket, which can be held under a chassis bolt, to lower the aerial slightly. As the lead to the set from this kind of aerial is generally so short it can be of unscreened wire.

With an open car it has often been found that a fairly effective makeshift aerial can be made simply by running a length of flex from the top of the windscreen to the tail, whilst another idea is to sew a length of flex to the inside of the hood cover, running it zig-zag from front to back.

### Interference Suppression

Even after attaching to the car the best possible aerial and taking care in earth-bonding the receiver, reception will generally be impossible while the engine is running unless suppressors are fitted to the ignition system. With commercially-made car-radio receivers ignition suppression is an extremely simple matter, but that is because suppressor inductances are included in the set, as mentioned last week. These call for special consideration in

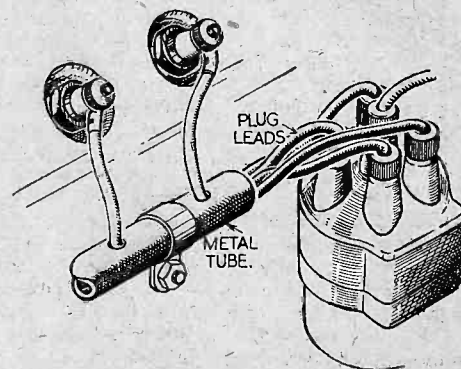

Fig. 2.—A method of screening the sparking-plug leads.

bolts or studs alongside the cylinder block or head (see Fig. 2). When the leads have to run for more than about 3in. from the distributor to the screening tube it might be necessary to pass them through a second short length of tubing, or to cover them with screening gauze which must be earthed to the engine, chassis or body.

It is scarcely necessary to emphasise the importance of ensuring adequate insulation between the earthed screening and the H.T. wires. At the same time

(Continued on next page.)

**CAR-RADIO EXPERIMENTS—II***(Continued from previous page)*

it should be pointed out that if there is any sign of perished rubber insulation of the leads, it is wise to fit new cables. There is a type of material on the market which has a silvered or glossy surface; this is very suitable since the insulation is very tough and impervious to oil.

**Earth-Bonding**

In the majority of cases it will be found that ignition interference is entirely eliminated by carrying out some or all of the work outlined. But if this is not the case re-examine the earth-bonding of the receiver and of the screening used for external leads before proceeding further. It should be possible, after having tuned in a station, to start the engine without any continuous noise being heard from the speaker; there will probably be a few crackles as the starter motor is switched on, but that is of little moment.

With the suppression system arranged as described it should even be possible to operate a fairly good portable receiver in the car while the engine is running, although it is better to have an external aerial connected to it. This type of set is seldom very satisfactory while the car

is in motion, because the A.V.C. circuit, if provided, will seldom be able to cope with the rapid and marked fluctuations in signal pick-up.

When ignition interference remains despite the steps outlined having been taken, it might occasionally be found that it is due to the proximity of the receiver and the coil. In that case a small can may be suitably drilled for the connecting wires and placed over the end of the coil to act as a shroud. For preference it should be a tight fit on the coil case and should be properly earthed.

**Other Sources of Interference**

Although the ignition circuit is mainly responsible for what might be termed dynamic (as opposed to static) interference, it is often found that some interference is radiated by the dynamo, direction indicators, windscreen-wiper motor, and lamp switches. Condensers—preferably metal-cased—can be used to “kill” the interference, by wiring them between the earth line and the “live” terminal, but before doing this it is wise to check and if necessary clean the contacts, commutator, bulb-holders and the like. The object of this is to prevent the occurrence

of the trouble rather than to cure it after it has been caused. Loose connections in any part of the electrical system can also be responsible for interference, and by arcing between H.T. leads and earth. It is evident, therefore, that it is far better to make a thorough check of the system than to fit numerous suppressors.

Static interference is far more difficult to trace, and an examination must be made for loose and rubbing metal parts, a loose exhaust pipe, loose body-holding-down bolts and things like these. This just brings to mind the difficulty experienced by a friend who fitted a running-board type of aerial of good commercial make. Interference was very bad, and in the end he decided to scrap the aerial and fit one of the roof type. When this was done reception was completely satisfactory, so he made a point of “advising” his acquaintances that running-board aerials were hopeless.

It so happened that he had fitted the aerial on the same side as the exhaust pipe, which was within a couple of inches of the aerial, and that the ignition coil was not very far from the front end. Had he transferred the aerial to the other running board it is more than likely that the interference would have been prevented.

**IMPORTANT BROADCASTS OF THE WEEK****NATIONAL (261.1 m. and 1,500 m.)**

Wednesday, July 5th.—Ronald Frankau revue, *Beyond Compeere*.

Thursday, July 6th.—*Life Begins at Sixty*, light entertainment.

Friday, July 7th.—*Macbeth*, Acts 1, 3 and 4, from Glyndebourne.

Saturday, July 8th.—*Summer Serenade: Up with the Curtain*, a variety entertainment.

**REGIONAL (342.1 m.)**

Wednesday, July 5th.—*Burford*, a programme from the Cotswolds.

Thursday, July 6th.—*The Classic Soil: Manchester to-day and a hundred years ago*, an interesting feature programme from North.

Friday, July 7th.—*Concert Party* programme.

Saturday, July 8th.—*Ithuriel's Hour*, adapted for broadcasting from the novel by Joanna Cannan. This is to be relayed from Wales.

**MIDLAND (296.2 m.)**

Wednesday, July 5th.—*Burford*, a programme from the Cotswolds.

Thursday, July 6th.—*Birmingham City Police Band*.

Friday, July 7th.—*Review of Revues: Orchestral concert*.

Saturday, July 8th.—*The Birmingham Air Port*. A recorded impression of the opening of the airport by the Duchess of Kent.

**WEST OF ENGLAND (285.7 m.)**

Wednesday, July 5th.—*Johann and Gertha*, a mime-ballet.

Thursday, July 6th.—*A Sonata Recital*.

Friday, July 7th.—*Light orchestral concert from the Continental Restaurant, Bournemouth*.

Saturday, July 8th.—*Ithuriel's Hour*, adapted for broadcasting from the novel by Joanna Cannan.

**WELSH (373.1 m.)**

Wednesday, July 5th.—*Radnor Forest: A programme compiled by Austin Jones and A. Watkin-Jones*.

Thursday, July 6th.—*A Concert from Bethania Congregational Chapel, Dol-lais*.

Friday, July 7th.—*The Royal Welch Fusiliers*, a sound picture of the regiment's life, relayed from the Barracks, Wrexham.

Saturday, July 8th.—*The Resurrection*, a story by Sam Jones, told by Clydach Thomas.

**NORTHERN (449.1 m.)**

Wednesday, July 5th.—*The North Country-woman—7*, a personal miscellany.

Thursday, July 6th.—*The Classic Soil: Manchester to-day and a hundred years ago*.

Friday, July 7th.—*Concert Party programme from the Spa Theatre, Scarborough*.

Saturday, July 8th.—*Pit Ponies at the Royal Show, Windsor*.

**SCOTTISH (391.1 m.)**

Wednesday, July 5th.—*The Scottish National Players in S for Sugar Candy*, a comedy by Donald Maclaren.

Thursday, July 6th.—*Scots Songs: Orchestral concert*.

Friday, July 7th.—*Students' Songs*.

Saturday, July 8th.—*Glints o' Sunshine*, a summer miscellany.

**NORTHERN IRELAND (301.1 m.)**

Wednesday, July 5th.—*Ballad Concert*.

Thursday, July 6th.—*Band Concert*.

Friday, July 7th.—*Gardening discussion*.

Saturday, July 8th.—*Where's that Tiger?* a farcical comedy by Ruddick Millar.

(See note on page 385.)

**NEW PLAY ABOUT GRACE DARLING**

THE story of Britain's first national heroine will be told in a new play, “The Fame of Grace Darling,” which is to be televised in the evening programme on July 9th, with Wendy Hiller in the name part. Incidentally, this will be Wendy Hiller's television debut and her first public appearance since her success in the Bernard Shaw film, “Pygmalion.”

The play has been written by Yvette Pienne, the well-known actress, who has been able to study television at first hand by taking part in several plays herself.

This original play gives the sequel to the story of Grace Darling's famous rescue off the coast of Northumberland. It will show that the heroine's reward was the perpetual turmoil which is the lot of anyone who becomes “news.” Besieged by trippers, pestered by souvenir hunters for locks of hair, and entreated by rival theatre managers to appear on the stage, the humble lighthouse keeper's daughter was quite overwhelmed until, under the strain, her health gave way and she died at the age of twenty-eight.

The Design Department at Alexandra Palace is now engaged in the difficult task of making scenery which shall give the impression of a lighthouse interior while allowing space for the actors. The “set” is being designed from a contemporary engraving of the Longstone Lighthouse, where Grace and her father lived.

It will be repeated in the afternoon programme on July 14th.



concerned is a member of a German short-wave club. If any lady readers are interested in short-wave matters (can there be lady short-wave readers of this journal?), I shall be glad to forward their letters, which should be addressed to me and marked G. K. in the top left-hand corner.

#### From an Old Wrinkler

**A**N old wrinkler residing at Castle Donington has conceived an idea to make the wrinkling public remember the coupon. The illustration (p. 391) shows his plan. Perhaps it is just as well that I should explain that "Wrinkle Writer" X in the diagram completes letter to the Editor *re* wrinkle, then proceeds to wet stamp on stamp lubricator (A), under which is concealed a press switch. This switch makes contact and completes circuit which causes patent vibrating pendulum (B) hanging on hook (C) to shake copy of PRACTICAL AND AMATEUR WIRELESS before the wrinkle-writer's eyes. The current from batteries K 1, 2 and 3 at the same time causes electromagnetic bolt (E) on door (D) to lock and sets into motion radiogram (F), which plays special record repeating "Do not forget the coupon" via loudspeaker (G) with 15 watts undistorted output. Meanwhile, electromagnet (H) is attached to the nails in wrinkle-writer's boots. This effectively prevents writer from going to the post. As magnet (H) is chained to stake (I) on the desk, trap door (J) flies up and on its surface is printed a copy of regulations concerning wrinkles "of the radio variety," which is read by the astonished writer of wrinkles, and he finds with horror that he must enclose a coupon with his wrinkle. This causes him to stop wetting the stamp, which releases the switch (to see the effect of releasing the switch the reader must read this instruction sheet backwards) and cuts the coupon from the PRACTICAL AND AMATEUR WIRELESS copy in front of his eyes. Thus another tragedy is prevented.

Wrinkle people who try this invention (given freely to the trade) are advised to tie two knots in their handkerchiefs, one to remind them about the coupon and the other to remind them why they built the machine herein described.

#### The "Practical Wireless Service Manual"

**O**N page 320 of this journal, dated June 17th, 1939, a printer's error occurred. The *Practical Wireless Service Manual* was announced as costing 3s. 6d. The correct price is, of course, 5s., or 5s. 6d. by post.

## Notes from the Test Bench

### Station Searching

**U**SERS of superhets of the standard type may have noted that some difficulty is experienced when searching for very weak stations due to the fact that the noise level rises with the A.V.C. action. A further point with this type of receiver is that C.W. signals cannot be obtained unless a regenerative stage is included. Both of these defects may, of course, be overcome if a beat frequency oscillator is fitted, as this enables the H.F. currents in the 2nd detector stage to set up a beat with the oscillations fed to it from the B.F.O. stage. If such a device is not fitted to the receiver it may, of course, be constructed as a separate unit and placed outside the receiver, but it must then be perfectly screened and a screened lead taken from it to the input to the 2nd detector stage. When adjusted, the reception of a station may be detected by a squeal in the same manner as when using an oscillating detector stage, and the oscillations must then be slackened off to render the speech or music intelligible.

### Multi Connections

**I**N some modern mains receivers and also in some battery sets it is often necessary to connect several wire-end components to one point. The difficulty which usually arises is that one or two parts are first placed in position and when additional parts are added the first connections come adrift. By using a number of soldering tags this difficulty may be overcome, but an alternative idea is to solder a length of bare wire to the point in question and then attach the various components round this lead at intervals, the result being that each may be made to point in the required direction and they may be added as wiring proceeds without risk of previous connections coming adrift.

### Microphone Feed-back

**T**HE main trouble when trying microphone circuits is that of feed-back which gives rise to a high-pitched howl as soon as the volume is turned up. Generally, this is due to the sound waves from the speaker impinging on the microphone and therefore the cure is so to place the two that they are "back to back" or as nearly so as possible. Instability can, however, give rise to a similar trouble and the input leads may have to be screened. The distance between mike and speaker is also a vital factor when instability of the type mentioned is experienced.

This valuable handbook is worth ten times the price charged.

### P.U.—Separate or Combined?

**F**.L., who resides in the salubrious district of Las Palmas, contributes his dicta, quota, opinion, pronouncement, moiety, or last word on the subject raised in a recent issue. This is what he says:

"I noticed in your article in No. 349 of PRACTICAL AND AMATEUR WIRELESS that you would like comments on the relative merits of plugging a P.U. into any old receiver, or building a complete radiogram.

"I have tried each and they both have their advantages and disadvantages.

"First of all why not use the transmitter's idea of the rack system? This was O.K., but hardly decorative, considering the whole was to be deposited in the living room.

"From this was evolved a unit with each section an independent unit—with multiple plugs for connections.

"Doors opening either sideways or downwards, according to which is most convenient, covering all panels except for the broadcast set—which is open to family use—this would hide the enormous multiplicity of knobs in which the real enthusiast delights.

"Switching or plugs could be used for connecting the individual receivers to the universal L.F. amplifier.

"The gram. turntable would be mounted on a hinged board swinging outwards for record changing, with gram-radio switch mounted on the broadcast panel, so that it, also, would be available for family use.

"The chief advantage of all this is, of course, that as each copy of PRACTICAL AND AMATEUR WIRELESS comes to hand, one could remove and modify any section according to the ideas therein, without having to dismantle the whole radiogram, or leave the family without music. (The L.F. section could be two sections also.)

### Arthur Askey's Life Story

**S**EEMS a long time ago now that most of England crowded round their loudspeakers every Wednesday night to hear Band Wagon with Arthur Askey. Many of the comedians who owe so much of their popularity to the radio are soon forgotten, but not "Big Hearted Arthur." I see he is now writing his life story for *Tit-Bits* and a most entertaining story it is too. He writes as he speaks. "Even when I cracked my first gag," he says, "It must have been an old one, because the rubber was perished."



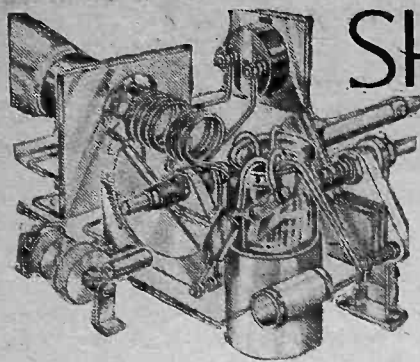

# SHORT-WAVE SECTION

## A SUPER-REGENERATIVE FOR THE ULTRA SHORTS

A Good Single or Two-valve Circuit for Portable or Standard Use on the Wavelengths below 10 metres.  
By W. J. DELANEY

value of about 20 or 30 m.mfd., and should preferably be of the ceramic type. A suitable component is obtainable in the range supplied by Webb's Radio, Raymart, Premier or Eddystone.

The condenser must be mounted on an insulated bracket. C1 and C3 are now indicated as variables, and the advantage of this is that it enables adjustments to be made when the receiver is first set up so that the maximum performance may be obtained. A small aluminium chassis should be used, and the two condensers, C1, an Eddystone type 978, and C3, a Bulgin C.P.4, should be mounted on the chassis—not the panel—as close to the grid and coil tap as possible. The H.F. choke, preferably the Eddystone wire-ended or a similar component on a ceramic base, should form the connecting link between the coil and C3. Other components may be perfectly standard, good-quality items, and no particular reference need be made. Wiring must, of course, be kept down to the minimum with due attention to spacing and right-angle crossings, and as the tuning of this type of receiver is not unduly sharp, there is no necessity for a high-class slow-motion drive for the tuning condenser. A moderately-g geared component in keeping with the general dimensions of the receiver should be used, coupled to the condenser through a ceramic type insulated coupling rod. The variable resistor in the H.T. feed must be a good component such as the Dubilier metallised, and if any alternative make is employed make quite certain that it has an insulated spindle and that it is smooth in its action. The remaining constructional details may be left to personal preference.

**A**LTHOUGH the superhet is obtaining well-deserved popularity for wavelengths down to 10 metres, there are many difficulties which arise when an attempt is made to get down to 5 metres or below. These difficulties are especially noticeable when portable receiver design is contemplated, and one of the most important is that of size. The superhet must use at a minimum four valves if it is to be worth while, but the frequency-changing stage is not entirely satisfactory down to 5 metres, unless special circuits are adopted, and even then the results often do not justify the use of the superhet principle. An H.F. stage also fails to pull its weight on 5 metres, and this forces the listener to adopt a straightforward detector-L.F. combination, and the many faults of this type of circuit become intensified on the ultra-shorts. The main sensitivity of the reacting detector is obtained from the reaction circuit, and therefore with

noise level or hiss which is obtained, but when it is properly set up it is definitely superior to the ordinary type of receiver, and this fact is borne out by the popularity of the circuit in special portable apparatus used by the Police and Army authorities. The essential features of a self-quench type of super-regenerative stage are shown in Fig. 1. It will be noted that the tuned circuit is across anode and grid instead of across grid and earth as in the usual arrangement, and the H.T. is fed to the centre of the tuning coil. Whilst the value of the grid leak is not usually critical, the grid condenser, C1, and the quench condenser C2 are of the utmost importance, and it is due to wrong values of these two components that most super-regen. receivers fail to give the desired results. A standard L.F. coupling may, of course, be connected in place of the 'phone terminals, and as this will introduce the need for higher H.T. to feed the following valve, some form

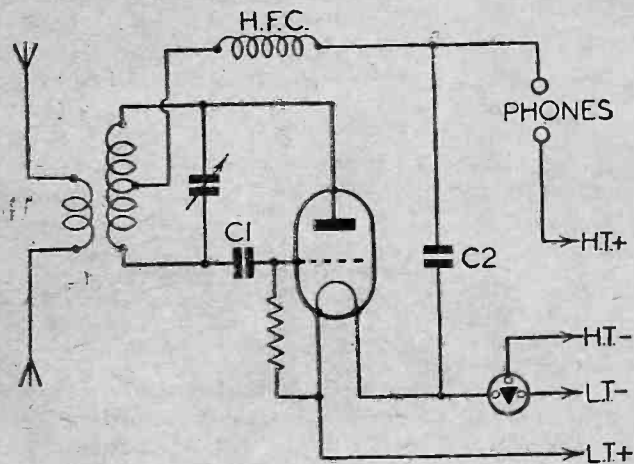

Fig. 1.—Main details of the self-quenching super-regenerative circuit.

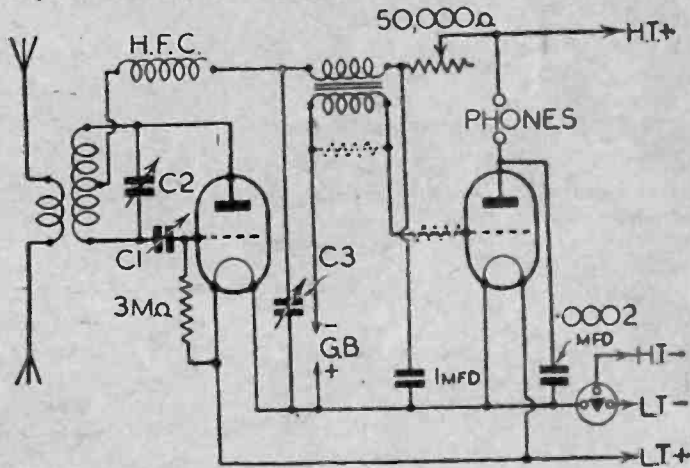

Fig. 2.—The complete 2-valve circuit using the super-regenerative arrangement.

a single valve it is necessary to rely upon some scheme which will enable the reaction arrangements to be operated faultlessly, especially if reliable long-distance reception is to be obtained. For the amateur transmitter this is one of the main points, and a receiver is needed with which the amateur band can be searched fairly quickly, but reliably.

### Reaction and Tuning

With the ordinary oscillating detector it is not a simple matter so to arrange things that the reaction setting is constant or so that it does not affect tuning, should it be found necessary to make a modification in the reaction setting. The super-regenerative type of receiver, on the other hand, may be made in a very reliable form, is extremely sensitive, and calls for no more elaborate apparatus than is used in an ordinary detector stage. Its main defect, from many listeners' point of view is the

of variable H.T. device must be included for the first stage.

### A Suitable Design

A two-valver is generally to be preferred on account of the better signal strength, where a portable type of aerial is employed, and this type of aerial will generally be used as no earth connection is then called for and the apparatus may thus be kept in use at all times. A full two-valve circuit is given in Fig. 2, and it will be seen that there is a minimum of components, thus enabling quite a compact set to be built up. For the tuning circuit and aerial coupling coil, the midjet Eddystone coil units (type 1050) are ideal, and it will be noted that a dipole aerial connection is indicated. Two short lengths of rod may be used, or if the apparatus is to be used with a cycle or ear, wires may be suspended in suitable positions for this purpose. C2 is a standard midjet short-wave condenser having a

### Operating Notes

When construction is completed, the receiver may be tested, and for preliminary working C3 should be adjusted to almost its maximum value and C1 to a mid-way setting. Connect phones and H.T. and slowly rotate the reaction control. A loud hiss should be obtained, and as the resistance is advanced this should cease. If the customary hiss cannot be heard, adjust both C2 and C3 slowly until you can obtain it, and endeavour to pick up a station—preferably a local amateur on 5 metres. When a signal has been obtained, it will be a fairly simple matter to adjust the two condensers mentioned until perfectly smooth results are obtained throughout the band covered by the coil in use. A setting of the resistance should be found, when the two condensers have been properly adjusted, where tuning may be carried out over the entire band of the coil

(Continued on the next page)

## Leaves from a Short-wave Log

### Rome on Ultra-short-waves

THE ultra-short wave transmitter which the E.I.A.R. recently opened at Rome (Italy) is now operating daily on 6.85 m. (43.8 mc/s) from B.S.T. 16.00-18.30. For the first time in the history of radio a new method of construction has been adopted. Instead of placing the transmitter at the foot of the aerial mast, it is actually built at the top, in a metal casing, and in this way loss of energy has been avoided. The station works with a power of 400 watts in the aerial.

### The Voice of the Orient

XMHA, formerly XGSB, a 20-kilowatt station at Shanghai (China), now works on 25.26 m. (11.875 mc/s) every day at B.S.T. 15.00. A news bulletin in the English language is broadcast at B.S.T. 15.45, followed by the Chinese National anthem. The address is: 445, Racecourse Road, Shanghai (China).

### Ici Radio St. Denis

FR8A, the 100-watt station at St. Denis, the capital of Reunion Island (French possession), has been heard by a listener in the British Isles between B.S.T. 19.00-20.00, broadcasting a programme of gramophone records. The wavelength is 31.25 m. (9.6 mc/s).

### Spain's Short-wave Stations

ALTHOUGH details of a regular schedule have not yet been published of the innumerable short-wave transmitters used during the Civil War, it would appear that the only ones still in operation are the following: EAR, Madrid, 31.62 m. (9.49 mc/s); EAQ, Madrid, 30.43 m. (9.86 mc/s); Malaga, 41.55 m. (7.22 mc/s); Burgos, 42.43 m. (7.07 mc/s); Valladolid, 42.43 m. (7.07 mc/s); EAQ1, Barcelona, 42.7 m. (7.03 mc/s); EAJ1, Barcelona, 21.35 m. (14.06 mc/s).

It is reported that the entire broadcasting network both on medium and short waves is to be reorganised in the near future.

### The 1940 Olympic Games

INFORMATION regarding the XII Olympic Games to be held in Finland next year is given out in a broadcast every first Monday and Tuesday in each month through Helsinki (3), Finland, on 49.02 m. (6.12 mc/s).

### Paris-Mondial Changes Channel

THE French Paris-Mondial broadcasts previously carried out on 31.41 m. (9.55 mc/s) are now heard on 41.21 m. (7.28 mc/s) daily from B.S.T. 16.15-18.45, and from 19.00-23.15.

### Radio el Mundo

THE Buenos Aires (Argentine Republic) stations LRU and LRX on 19.62 m. (15.28 mc/s), and 31.06 m. (9.66 mc/s) respectively, relay the programmes of the medium-wave studio LRI, operated by the owners of the daily newspaper *El Mundo*. LRU works from B.S.T. 13.45-15.30, and LRX from 15.45-05.00 daily. Address: Radio el Mundo, Calle Maipu, 555, Buenos Aires.

### A Call from St. Kitts

THE Caribbean broadcasting service is now establishing a regular schedule of broadcasts from its 250-watt transmitter ZIZ, situated at Basse-Terre in that island. The station works on 49.3 m., 6.085 mc/s.

### And from the Bahamas

ZNS, Nassau, a 200-watt station installed by the island authorities, provides a varied radio programme at B.S.T. 19.30-20.00, and from 02.00-03.00, on 49.26 m. (6.09 mc/s). The distance from London is roughly 4,400 miles. Address for reception reports: Office of Superintendent of Telegraphs, Radio Station ZNS, Central Pay Street, Nassau, Bahamas.



A studio portrait of Gloria Brent, the attractive "croonette," heard on the air with Bram Martin, Jack Jackson and other bands.

### The Short-wavers of Panama

IN Panama City (Republic of Panama) there are now five short-wave transmitters, of which HP5J, *La Voz de Panama*, is the most important. This station operates with a power of 3 kilowatts on 31.23 m. (9.607 mc/s) daily and reception of its broadcasts is an easy matter from midnight B.S.T. onwards. The studio closes down with a march: *The Black Horse Troop*. HP5G, a 750-watter, is frequently heard on 25.47 m. (11.78 mc/s). In a similar way to the U.S.A. studios, it puts out its announcements and call every fifteen minutes. HP5H, *La Voz del Pueblo*, also in the capital, is recognisable by its single-chime interval signal; the wavelength is 49 m. (6.122 mc/s). HP5A, giving as its call *Radio Teatro de la Estrella*, on 25.64 m. (11.7 mc/s), works on 300 watts and may be identified by its two-toned gong. An English news bulletin by an Englishman is given out nightly at G.M.T. 23.30. HP5B, *Estacion Miramar*, on 49.75 m. (6.03 mc/s), as an interval signal has combined the stroke of a gong with a cuckoo call. The power is 200 watts. Coupled to the call is the announcement in English that the broadcasts are from the

land which is divided so that the world could be united and "where palm trees grow and two oceans flow." In addition to the short-wave stations at Panama City there are smaller stations at Aguadulce, such as HP5I, *La Voz del Interior*, on 25.22 m. (11.895 mc/s); at David (Chiriqui) HP5L, *La Voz del Istmo* (Isthmus), on 25.55 m. (11.74 mc/s), 300 watts, and two stations at Colon, namely *La Voz de la Victor* (HP5K), on 49.96 m. (6.005 mc/s), 1 kW, and HP5F, *La Voz de Colon*, on 49.59 m. (6.05 mc/s), 300 watts, which in the early hours of the morning closes down with that popular melody *The Whistler and His Dog*.

### El Salvador Calls

SAN SALVADOR, in the Republic of that name (Central America), is said to be developing its broadcasting organisation. So far, only two short-wave stations in the capital have taken the air, namely, YSM, on 25.62 m. (11.71 mc/s), and YSH, on 31.51 m. (9.52 mc/s).

### SHORT-WAVE SECTION

(Continued from previous page)

without any other adjustment than the rotation of the tuning dial. In the event of erratic action throughout the range the value of the grid leak may be changed, but with most valves which are suitable for this type of circuit a value of 3 megohms will be found satisfactory.

It will be noted that two resistances are indicated in broken lines on the L.F. side of the receiver, and these may be necessary with some layouts to prevent threshold howl, a peculiar form of squeal which is not easy to describe but which is immediately identified should it occur. The resistance across the transformer secondary should be about  $\frac{1}{4}$  megohm, whilst the series grid-resistor should be between 15,000 and 25,000 ohms.

### Mains Operation

This same circuit may, of course, be included in a mains-operated receiver, but there are one or two points which must be watched carefully. Firstly, the difficulty of hum is not easily overcome, and preferably the receiver should be self-contained, in a metal box, with the mains unit completely separated. The choice of mains components in the mains section is not unduly critical, but the smoothing is of the utmost importance. Either valve or metal rectifier may be used, but the smoothing condenser on the receiver side of the choke should be 16 mfd. at least. This may be obtained from two standard 8 mfd. electrolytics connected in parallel. As a general rule, however, a receiver of this type would not be recommended for general "indoor" use, and therefore its main utility lies in the direction of portability with high sensitivity, for which purpose battery supplies must be used. For standard reception at home, a receiver with a good H.F. stage preceding a standard reacting detector would be calculated to give better results, but, of course, the layout and general design would be much more critical and the receiver would not be so compact.

### PATENTS AND TRADE MARKS

Any of our readers requiring information and advice respecting Patents, Trade Marks or Designs, should apply to Messrs. Rayner and Co., Patent Agents, of Bank Chambers, 29, Southampton Buildings, London, W.C.2, who will give free advice to readers mentioning this paper.



**T**HIS receiver has been designed for the more advanced constructor, and incorporates practically every device known to modern radio to obtain the best possible results in the simplest form. The tuning unit used is accurately aligned and needs no trimming adjustments—the only trimming needed is that of the I.F. transformers which, as described later, is very simple indeed. The set has been designed to provide a high standard of reproduction from local stations, and sensitivity and selectivity are adequate for most Continental transmissions on the broadcast bands and principal short-wave transmissions.

The wave-ranges are: 16.5-51; 200-500; 800-2,000 metres, and it has excellent sensitivity, giving loudspeaker reception of the principal stations of the world, through a push-pull output stage ensuring distortionless reproduction.

Construction itself is not very difficult, but is best not attempted except by those who can solder well.

The circuit consists of a triode-hexode frequency-changer valve preceded by a set of H.F. transformers with an I.F. filter incorporated on the long waves. The succeeding valves comprise an I.F. amplifier, double-diode-triode for detection, A.V.C. and L.F. amplification, phase-reversing valve and push-pull output stage with valve rectification for the power supply.

A triode-hexode has been chosen for the frequency changer as it is easier to secure freedom from serious interaction effects between the signal and oscillator circuits, especially on short waves. Moreover, there is less chance of the oscillator frequency being affected by the A.V.C. voltage applied.

All the tuning equipment is built on a rubber-mounted sub-chassis, and the frequency changer valveholder is also fixed to the main chassis through rubber grommets to reduce any tendency to microphony.

# The 1939 ALL-V

## A 6-stage, 7-valve (including Tuned Circuits which can be

tion on strong signals is considerably lessened.

The coupling between the frequency-changer and the I.F. valve is by means of a 465 kc/s I.F. transformer with top grid lead, and a similar I.F. transformer, but with all leads at the bottom, is used between the I.F. and detector stages.

### Second-channel Interference

An intermediate frequency of 465 kc/s has been chosen on account of the greater freedom from second-channel interference (in London, for instance, with two powerful local transmitters, there is one second-channel whistle only, and that occurs on the long-wave band and is greatly minimised by the filter coil incorporated in the tuning unit), and also because the tuning circuits in front of the frequency-changer can be made much more simple without sacrificing selectivity or sensitivity.

The diode detector is usual in every way. One diode is used for detection and, after rectification, passed on to the grid of the valve for amplification in the usual manner. Note the use of the I.F. filter resistance and condensers. The other diode is simply used for A.V.C. and derives its voltages from the first diode by means of a 0.0001 mfd. coupling condenser. Full A.V.C. is applied to both the I.F. and frequency-changing valves.

The bias applied to the double-diode-triode valve has been reduced to approximately 2 volts and, as this voltage is also

useful on short waves. We cannot claim that it will hold a rapidly changing short-wave signal, but it has been found possible to listen to Schenectady, U.S.A., for in-

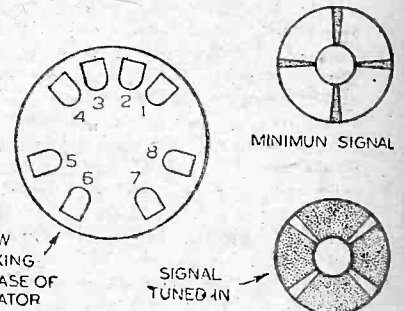
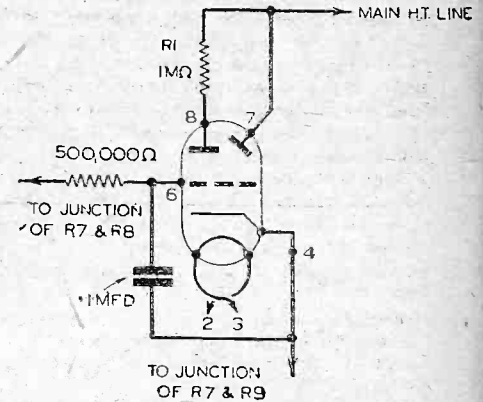

Connections and details of the visual tuning indicator.

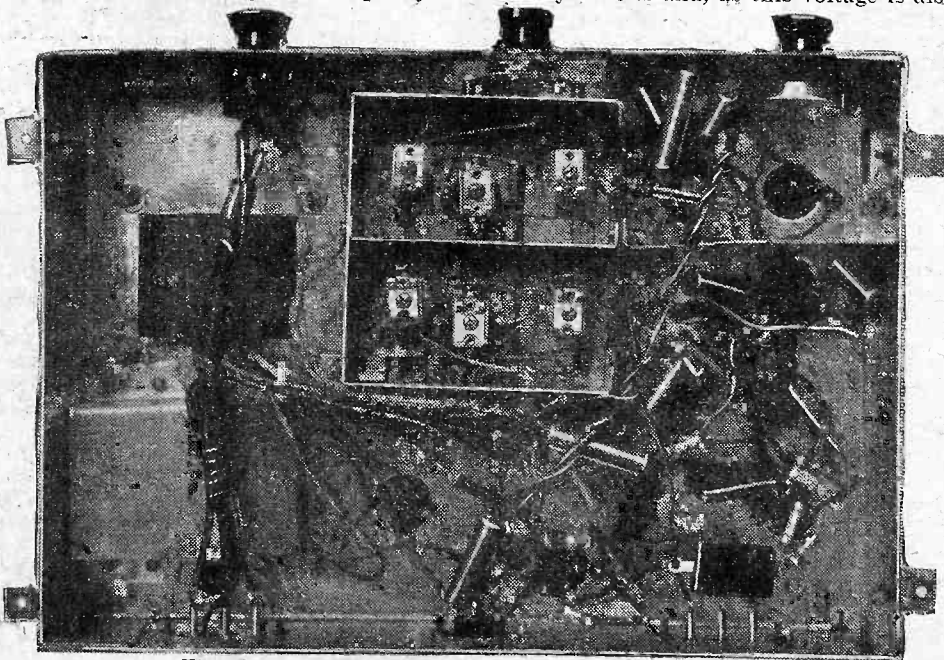

This shows the underside, with the coil trimmers and screens.

The I.F. valve is a variable-mu H.F. pentode controlled by the A.V.C. system. The screen is fed direct from the main H.T. line instead of through the usual potentiometer so that the grid base of the valve is lengthened and the possibility of distur-

the delay, results in the A.V.C. control being more than usually effective. It is not so great as to mar the performance of the receiver by cutting down sensitivity, but it is good enough to control all but the very weakest of stations, and is especially

stance, for well over an hour without the volume changing very much, although a meter in the anode lead of one of the controlled valves showed that the station was continually fading, at times very quickly indeed. It was only on the latter occasions that change in volume from the loudspeaker was apparent.

The output from the double-diode-triode valve is fed by resistance-capacity coupling to the grid of the phase-changing valve.

In order to make use of one of the diodes of the double-diode-triode valve for A.V.C. purposes, it was not possible to have the cathode of this valve at the same potential above earth as the cathode of the phase-changing valve. This meant that the latter valve did not amplify, but to have made it do so would result in added complications in the receiver caused by the addition of a separate A.V.C. valve or Westector. It was also found that the detector valve was very prone to hum under these circumstances, so this valve was made normal in every way and the AC/HL used for frequency-changing only.

### A Warning

It will be noted that the usual anode load resistance of the AC/HL has been split, and one half used in the cathode lead. It is well known that A.C. currents appear

# AVE SUPERHET

er) All-wave Superhet with Six  
for An Approximate Cost of £8

both in the anode and cathode leads of an L.F. amplifying valve, so that by putting a load resistance in each lead we are able to tap off A.C. currents from both the anode and the cathode, and these currents are always in opposite phase to one another. This is a very simple and inexpensive way of obtaining phase-reversal for feeding a push-pull output stage, but it has one snag in that the cathode is about 100 volts "up in the air." In other words, the voltage difference between the cathode and the heater is at least 100 volts, and there may be some danger of the insulation between them breaking down. Most modern valves will easily withstand this voltage difference, however, and we have no reason to believe that the life of the valve used will be impaired.

The push-pull output stage has been made as simple as possible, consistent with good quality.

Two Hivac AC/Z Harries power-output valves have been used. Each valve passes an anode current of about 30 mA, and the two valves require a load impedance of 12,000 ohms with 250 volts on the anode and screen. They are capable of an output of over 6 watts, and their high mutual conductance of 8 mA/V enables them to be operated direct from the diode detector without an intermediate L.F. stage. (As explained above, the AC/HL valve does not amplify at all.) The AC/Z valves employ the Harries critical distance anode principle, and give greater power output and sensitivity with a much lower level of distortion. For normal loads and drives, such as are encountered in this receiver, the distortion is as low as that of a triode.

When two valves in a push-pull stage are operated from separate filament windings

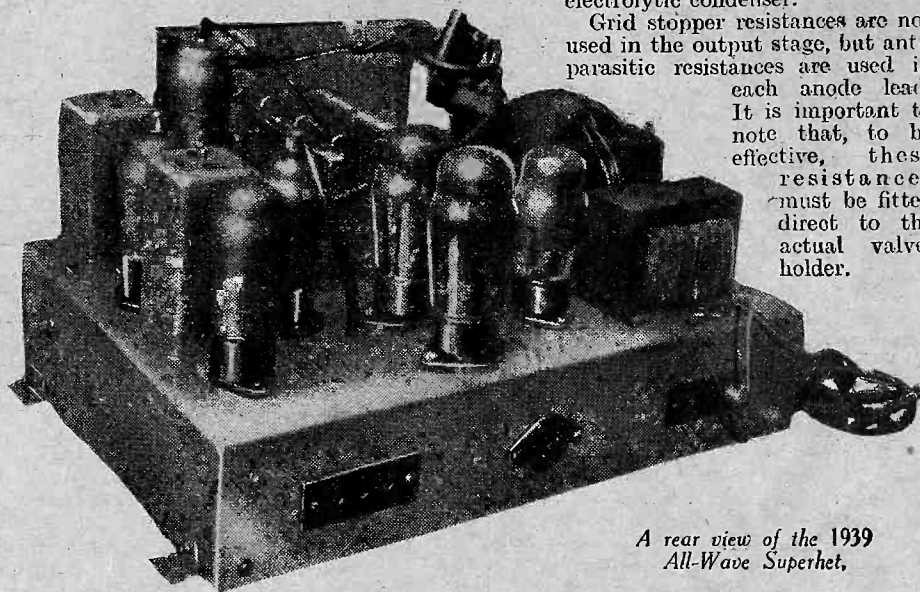

A rear view of the 1939 All-Wave Superhet.

balanced push-pull stage, no speech currents flow in the common cathode circuit, and by using this arrangement a saving is made of two windings on the mains transformer, a bias resistance and two condensers. Little is lost in performance, the only drawback being that there may be some reduction in valve life. As the emission of one of the valves falls, it passes a lower anode current and the grid-bias along the cathode resistor is reduced to offset the change. With the circuit used in this receiver, such a reduction in bias would affect both valves, so that the anode current of the good valve would tend to rise and the valve be over-run. In

### Good Stability

A glance at the circuit below will show that the receiver is devoid of practically all decoupling, and that even cathode by-pass condensers have been omitted. The receiver which forms the subject of this article has been found to be absolutely stable on all wavebands except at the very bottom of the long-wave band, where there are, of course, no stations to be received. The hum level is quite good, but as the designer is somewhat hypercritical on this score, an L.F. choke (Varley type D.P.51, 12s.) has been inserted between the rectifier and the speaker field. The 8+8 mfd.

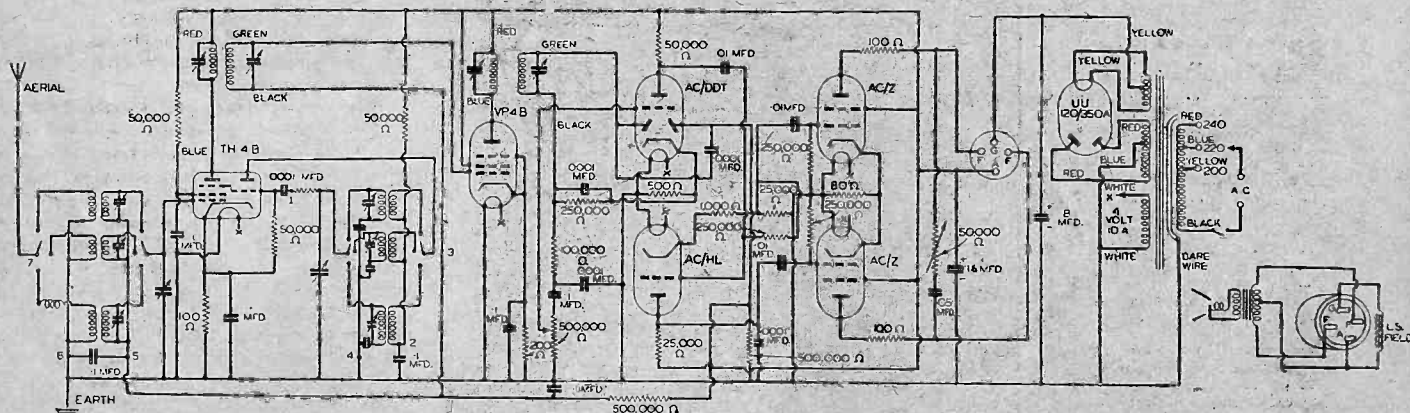

Complete theoretical diagram of the receiver, showing the speaker connections.

on the mains transformer, each must have its own cathode resistance and by-pass condenser. When they are run from a common filament winding, however, a common bias resistance may be used and no by-pass condenser is necessary. This is because with a properly designed and

practice, however, it will almost certainly be found that both valves will deteriorate to about the same degree, and unless, as is hardly probable, one valve fails very suddenly at an early stage of its life, no damage is likely to occur. Extended tests over a period of several months have not

condenser C.15 has been separated, one lead being taken to the main H.T. smoothed lead as before and the other to the junction of the choke and field.

Should a good earth not be available, however, instability and hum may occur.  
(Continued on next page)

1939 ALL-WAVE SUPERHET

(Continued from previous page)

The latter will almost certainly be picked up in the detector and phase-changing valves, and 10,000 ohm resistances and a 0.1 mfd. by-pass condenser should be tried in each anode lead in turn. It is probable that only one of the valves will need to be decoupled in this way, but in very severe cases, both valves may need this treatment. Instability will most likely occur in the anode of the frequency-changer valve, in which case a resistance of 2,000 ohms and a by-pass condenser of 0.1 mfd. in the lead to the I.F. transformer should effect a cure.

The mains equipment consists of a full-wave rectifying valve and reservoir condenser, smoothing being carried out by means of the speaker field and an 8 + 8 mfd. electrolytic condenser. All three condensers are contained in a common cardboard container.

The H.T. winding of the mains transformer is rated at 350-0-350 volts, the rectifier L.T. 2.0-2 volts 2½ amps., and the filament winding for the receiving valves 4 volts 10 amps. This winding allows ample reserve for the dial lights and a cathode-ray tuning indicator, if one is used. It is not centre-tapped, one end going to earth, simplifying heater wiring and minimising the possibility of hum, as one side of each valve-heater is taken direct to earth.

The mains transformer is of the skeleton type, but efficiency has not been sacrificed. Unnecessary trimmings only have been removed and colour-coded leads used as follows:

PRIMARY.

- Common .. Black
- 200/210 .. Yellow

- 220/230 .. Blue
  - 240/250 .. Red
- SECONDARY.
- Rectifier H.T. Red with blue centre-tap.
  - Rectifier L.T. Yellow
  - Receiver L.T. White cotton cover
  - Screen .. Bare wire

Tone control is carried out by means of an 0.05 mfd. condenser and a 50,000-ohms potentiometer connected between the anodes of the two output valves.

Construction and wiring is fairly simple and need not take more than an evening or two.

Having made the chassis, the first thing to do is to cut out a hole for the mains transformer and also one to enable the tuning condenser of the coil unit to project through the chassis. Mount these two components in place and then fix a metal screen, the total depth of the chassis (3in.), in the position shown by the wiring diagrams

and photographs. This screen is a good aid towards ensuring stability in a simple manner.

Mount the rest of the components and then wire up. It is a good plan to solder up all the leads to the mains transformer first of all and then carry on with the heater wiring. After this, each valve may be wired complete, commencing with one of the output valves and proceeding to the frequency-changer. Having completed this, check very carefully and make sure that all joints are sound. Look especially for dry joints as these can greatly mar performance.

No fuses are incorporated, so if you are at all uncertain, put a temporary 150 mA fuse in the H.T. lead; that is, between the rectifier H.T. centre-tap on the mains transformer and the speaker field.

Operating Notes for this receiver will be given next week.

WIRING DIAGRAMS

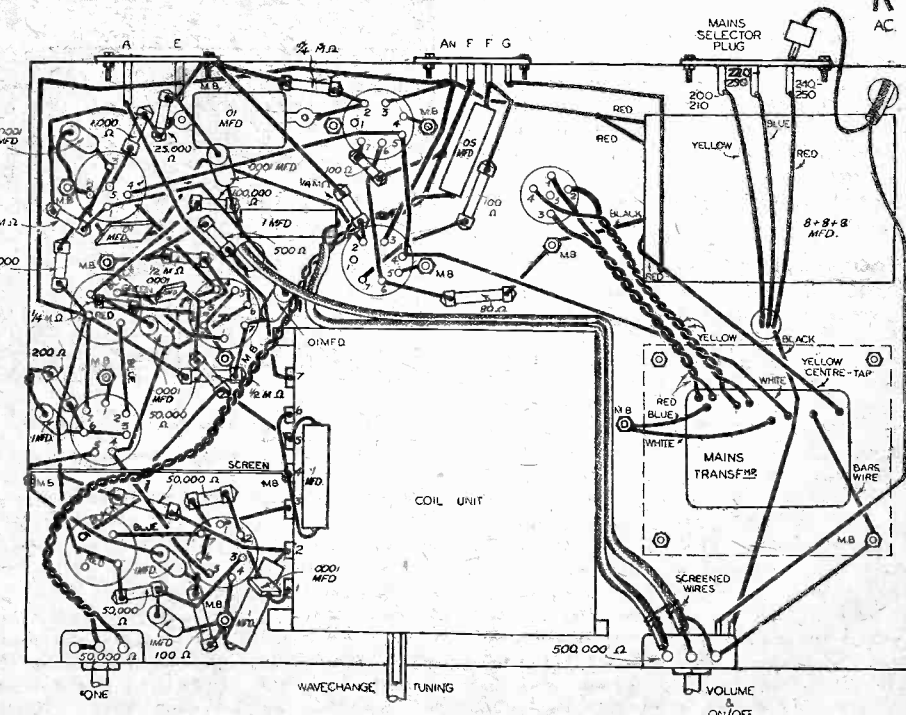
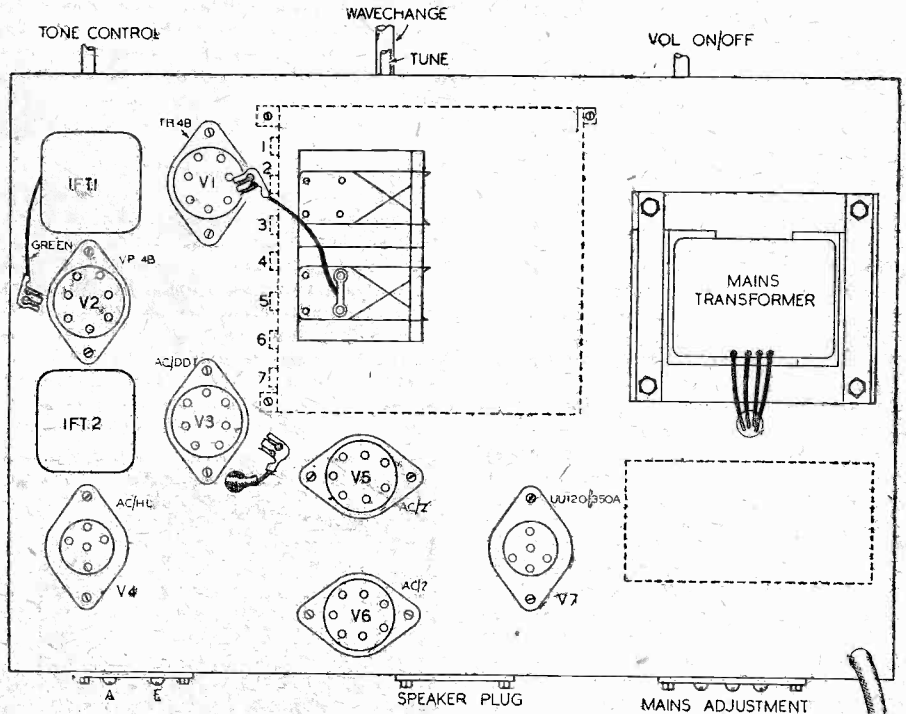

LIST OF COMPONENTS

	£	s.	d.
One J. B. Linacore all-wave tuner (mains model)	2	15	0
One Varley 465kc/s I.F. transformer type BP.122	7	9	
One Varley 465kc/s I.F. transformer type BP.123	7	9	
One volume control with switch, Dubilier type J. 500,000 ohm.	5	0	
One tone control (50,000 ohm), Dubilier type B	3	0	
Three 5-pin valveholders, W.B.	1	6	
One 7-pin ceramic valveholder, W.B.	1	6	
Four 7-pin valveholders, W.B.	3	4	
One A.E. terminal strip, Bulgin P.51	4	½	
One mains adjustment strip, Bulgin P.62	4	½	
One mains transformer, Varley special	1	17	6
Six 0.1 condensers, Dubilier type 4603/3	8	0	
Five 0.0001 condensers, Dubilier type 4601/S	5	0	
Three 0.01 condensers, Dubilier type 691W	6	0	
One 8 + 8 + 8 mfd. electrolytic block, Dubilier C.3107	6	6	
One 0.05 mfd. condenser, Dubilier type 4602/S.	1	3	
Four 50,000-ohm resistances, Dubilier F½	2	0	
Three 100-ohm resistances, Dubilier F½	1	6	
One 200-ohm resistance, Dubilier F½	6		
Four 250,000-ohm resistances, Dubilier F½	2	0	
One 100,000-ohm resistance, Dubilier F½	6		
One 500-ohm resistance Dubilier F½	6		
One 1,000-ohm resistance, Dubilier F½	6		
Two 25,000-ohm resistances, Dubilier F½	1	0	
Two 500,000-ohm resistances, Dubilier F½	1	0	
One 100 less 15 per cent. resistance (80 ohm nearest), Dubilier BW.1	1	0	
	£8	0	4

- One Mullard TH4B.
- One Mullard VP4B.
- One Hivac AC/DDT.
- One Hivac AC/HL.
- Two Hivac AC/Z.
- One Hivac UU/350/120A.
- Speaker—1,250-ohm field, transformer to match 12,000 ohms load—W.B.



# Practical Television

July 8th, 1939. Vol. 4. No. 159.

## Using Extreme Caution

IF one takes the trouble to investigate the television position in any country where development is taking place, it would seem that the watchword of those in control is caution. The latest to come within this category is America, as shown in a report just published by the Federal Communications Commission. The F.C.C. and the R.M.A. do not appear to see eye to eye in matters relating to television, especially on the question of picture standards. A word of warning was issued telling both the public and the industry not to expect too much from television in the near future. They voiced the opinion that the best practices would automatically become standards without any attempt at fixing them, for if the latter course was adopted this would tend to restrict the art into a single groove. While not objecting specifically to the picture standards recommended by the R.M.A. the F.C.C. rather felt they were not at present really applicable to the higher frequency channels now reserved for television. This may be taken to mean that the line dissection standard of 441 lines is not really sufficient to give pictures of outstanding quality as improvements in technique are brought about, and this seems a very reasonable assumption. In spite of the very marked public interest in the television transmissions inaugurated in New York, only 200 sets had been sold in the first two weeks of May, and this slow start is regarded with dismay by those connected with the receiver industry. The average set price is much higher than that ruling in this country, and British sets imported into New York have given better results than the American ones, and yet they are only listed at half the price of the American sets. Everyone is looking forward to the advent of mass production, and until this does occur there seems little likelihood of the F.C.C. licensing stations on a commercial basis whereby they can derive revenue from advertising, as is done by the various radio chains.

## Further Financial Inroads

THERE has been considerable controversy in the boxing world concerning the sum of money which can justifiably be expected as a contribution from television interests for rediffusion rights. First of all, the matter was considered by the British Boxing Board of Control at the annual meeting held in Cardiff. The board, in the past, has been paid a percentage on certain rights, but now a new resolution has been passed stating that in all championship contests and tournaments where the gross takings for admission, including fees for television, broadcasting, film and still picture photography are £2,500 or more, then 5 per cent of the gate receipts should be paid by the promoter to the B.B.B.C. It is significant that the television clause has now been included, it being felt that in the future this may represent a really substantial amount,

especially when more and more cinemas are equipped with big screen apparatus. Following on this, two of the foremost boxing promoters have decided that they will no longer accept the "facilities fee" of £75 to £100, usually paid by the B.B.C. for putting the match on the air as vision and sound signals. They maintain that the basis of investigation should be a percentage of the amount guaranteed to the boxers as purses. Whether this will prove satisfactory only time will tell, but as far as cinemas are concerned it would seem far more satisfactory to claim a percentage of the theatre's takings.

## A Renewed Television Attack

CERTAIN Members of Parliament have renewed their relay of questions to the Postmaster-General on the subject of television, and the latest seem to be directed more towards the Television Advisory Committee, which, contrary to expectations, has delayed the issuing of its report. The reasons for this delay are something of a mystery, and the Parliamentary questions are designed with the object of clearing up this unsatisfactory

instead of a paltry one. Germany has already made known its plans in this connection, and unless moves are made swiftly, this country will be left behind in national television as opposed to a service from a single station. The radio, theatrical and cinema interests have all sent deputations to Major Tryon, and whereas the last two may be apprehensive of competition, it should be possible to introduce safeguards to ensure that existing forms of entertainment are not seriously injured by television. Readjustments must take place, and it is common knowledge that similar doubts and fears have been expressed from time to time, by the entertainment industry, on the effects of broadcasting from the theatres, cinemas and music-halls. It is now realised, however, that broadcasting can provide an invaluable publicity medium, and the same will ultimately be found with television if its progress is not restricted by the expression of petty jealousies from other quarters.

## The Big Screen in New York

A FEW days ago the Baird big screen receiving equipment was demonstrated in New York to a large audience which included representatives of all the leading American newspapers, cinema circuits, and theatre interests. According to reports which have so far come to hand this event was acclaimed as an outstanding success, the programme being furnished by an hour's broadcast from a television studio. So far the Americans have only been able to see results on home receivers where the picture screen size has an average below that obtaining in this country. The occasion was historic, therefore, as for the first time those in the



W. Kirby, Managing Director of Currys Ltd., photographed "on the set" with stars Mary Maguire and Richard Ainley. The radio shop scene was built by Currys for the new film "An Englishman's Home," now being directed by Albert De Courville at Denham Studios.

situation. To his last two questions the P.M.G. had to admit that no decision had yet been reached regarding extending television facilities into the provinces, but said that due consideration would be given to the claims of all densely populated areas. Now that it is felt generally that Birmingham will be given the first provincial station, other big cities have put forward their claims with renewed vigour, and will not rest until provincial facilities are provided for several areas

theatre saw a 15ft. by 12ft. television picture, for no other television company in the United States has yet attempted to show results of this nature. It was conceded that this triumph of British enterprise should do much towards accelerating the development of the industry in that country. The equipment was identical in character to that used recently in London, except that alterations had to be undertaken in the electrical circuits to suit the standards of the American radiated picture.



Further P.A. Considerations. Triodes and Pentodes; Feed-back and its Elimination, and Fixed and Variable Bias, are Dealt with in this Article.

By L. O. SPARKS.

TO avoid any misunderstanding over Class B operation, as described in the issue of last week, it must be appreciated that the curves used to depict the operating conditions only applied to a single triode valve. This point is stressed as some readers might try to apply them to an L.F. Class B amplifier with rather confusing results.

When considering the L.F. application, the fact must be appreciated that two

It is highly probable that a beginner will think of a simple triode of the power or super-power type for use as a P.A. In view of the previous remarks it might seem that such an arrangement would be the easiest and most satisfactory, but, unfortunately, there are certain snags which reduce the advantages which appear to exist at first sight.

The first of these is the question of instability. It must be remembered that in a

circuits, it is usually essential to provide some means of nullifying the inter-electrode capacity of the valve itself, apart from paying attention to the layout and wiring of the associated components. The process of eliminating the inter-electrode capacity is known as *neutralisation*, but that must be dealt with in detail in the next article.

Apart from this little snag, if a triode is operated under Class A conditions its efficiency is on the low side, as it requires a comparatively powerful input signal to drive the anode circuit to maximum output.

The efficiency of such an arrangement can be improved considerably by using two triodes in Class A push-pull, as this will increase power output and reduce any, even harmonic, distortion. Neutralisation must, of course, be still applied to each valve; in fact, if perfect conditions are

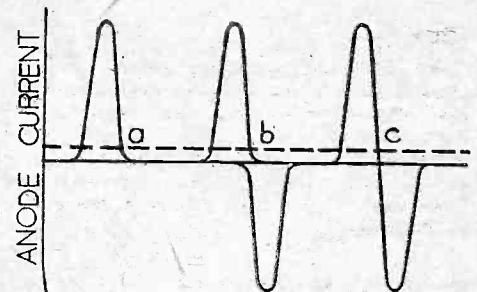

Fig. 2.—The output of a single valve is shown as "a". The effect of using two is "b" and the final result is as shown by "c".

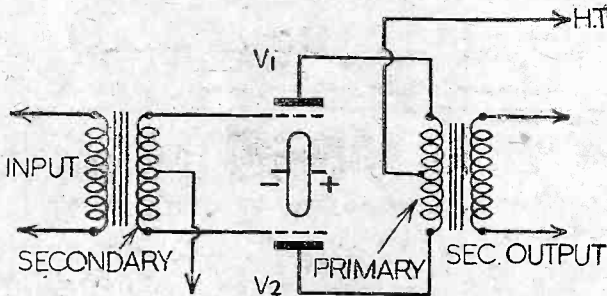

Fig. 1.—This shows the L.F. arrangement for Class B operation. Note the two triode sections.

separate triodes, or, as in the case of a modern Class B valve, where two triode sections are enclosed in a single glass bulb, are used, so that the single peak output waveform is converted into an amplified version of the input signal. Space does not permit a detailed description, therefore Figs. 1 and 2 must suffice to illustrate the operations. When the signal in the upper half of the input transformer is positive, anode current will flow in V1, while the anode current of V2 will be practically zero. Within a minute fraction of a second, however, the conditions are reversed, and the bottom half of the input secondary becomes positive, and current flows in V2, while V1 is idle.

The output transformer has a centre-tapped primary which enables these two distinct operations to combine to induce in its secondary a signal having a wave-form identical, though, of course, amplified to that of the input signal. Fig. 2 shows the actual result.

**Triodes and Pentodes**

With so many of us, the choice of a circuit or apparatus is not always governed by technical considerations; more often than not the available components play an important part in deciding the issue. The selection of a P.A. circuit is no exception, so let us see what each form of amplification has to offer, so that full use can be made of the valves which might be to hand.

P.A. stage the grid and anode circuits are tuned to the same frequency, therefore, unless particular care is taken in circuit design and operation, the valve will act as a T.P.T.G. oscillator, and completely ruin the whole circuit.

With the grid and anode circuits tuned to the same frequency, the slightest trace

required, the valves themselves should also be matched as regards loading and characteristics.

**Pentodes**

In view of, shall we say, the defects associated with triodes, they are not now so widely used in low-power rigs, as it has been found to be far more simple to take advantage of the characteristics of pentodes. By virtue of their construction the inter-electrode capacity of a pentode is practically eliminated owing to the screening between the grid and anode circuits, therefore, in the majority of cases when a well-designed pentode is used, neutralisation is rendered unnecessary. This not only simplifies construction but increases ease of operation. It must not be thought, however, that by using a valve of this type the question of layout and wiring can be treated lightly, as every precaution must still be taken to

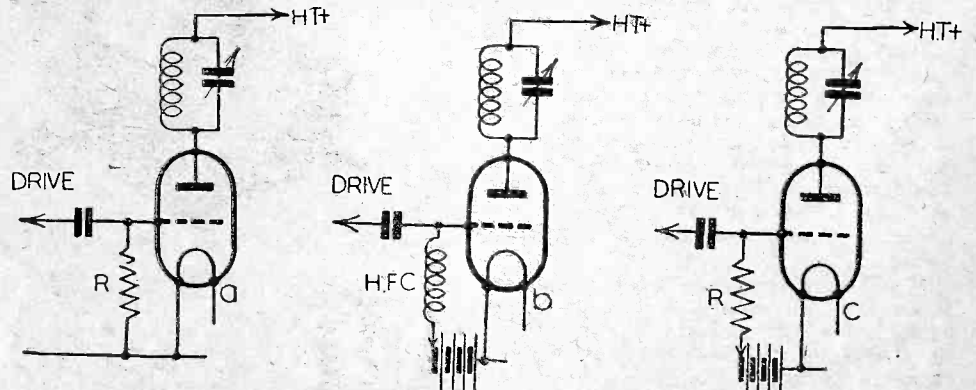

Fig. 3.—Biasing methods: "a" plain grid-leak; "b" batteries only, and "c" batteries and grid-leak.

of feed-back will produce oscillations, and as such feed-back can be introduced magnetically, i.e., by poor layout, long connecting wires or interaction between the two circuits externally, and, secondly, by capacity between the grid and anode

see that no feed-back is introduced externally.

**Class B**

The efficiency of valves in a P.A. stage operating under these conditions is much



higher than similar valves in Class A, but, owing to the losses across the grid circuit which are introduced by the grid current, the preceding stage must be capable of providing the additional drive thus required. By the correct use of suitable meters it is not a difficult matter to produce the correct operating conditions, but, all the same, the beginner would be wise to avoid such circuits until a sound general knowledge of Class A and valve adjustments has been acquired.

In certain transmitting circuits, the radio-frequency currents are actually amplified after modulation has been applied, and in such instances it is essential for linear amplification to be obtained. It is in this connection that Class B amplification becomes essential. Another word of warning: The beginner is not advised to try his hand at this operation.

**Class C**

An amplifier operating under Class C conditions has very little application to low-frequency circuits, but, owing to its high anode efficiency, it is certainly very effective for P.A. work, providing the driving power, which must be even much greater than that required for Class B operation, is available.

**General Considerations**

With self-excited oscillators it has been mentioned that for stability and output a high value of capacity and low inductance were desirable. With P.A. circuits, however, the conditions are reversed and it is very essential to use the largest possible inductance together with the smallest capacity. There are, of course, limiting factors, and the question of the L/C ratio is one which should be fully investigated by all would-be transmitters, therefore more detailed consideration will be given to the subject at a later date.

**Bias**

With any of the forms of amplification already mentioned certain grid-bias voltages have to be applied, and in the case of Class B and Class C the safeguarding of the grid-bias voltage becomes absolutely essential if the life of the valves is of any consideration. It is possible to obtain bias by means of a simple grid-leak resistance, the bias voltage being produced across the resistance by the grid current flowing in the case of Class B and Class C operation.

It is quite usual, however, to employ suitable batteries to provide the required voltage, and this has the advantage of maintaining a constant value and protecting the valve in the event of the input signal failing or being suddenly removed. In many circuits use is made of a grid resistance and battery as this reduces the size of the battery required, owing to the fact that use is made of the bias voltage developed across the resistance, as mentioned above.

When a grid resistance only is employed, it must be appreciated that if the input signal is removed no grid current will be developed and likewise no bias voltage created, therefore the valve would be receiving a high anode voltage which, with no bias on the grid, would cause excessive anode current to flow, with detrimental effect to the valve.

**The CYCLIST - - 2d.**  
Every Wednesday.

**1939 All-Wave Superhet Pilot Kits**

● Build this "Pr. Wireless" Winner!  
**KIT "A" CASH £9:3:0 or 15/9 down**  
and 12 monthly payments of 15/9.

Pilot Kit A comprises all specified parts for Receiver including J.B. All-wave tuner, mains transformer, condensers, drilled steel chassis, wire, flex and screws, but less valves, speaker and cabinet.  
7 specified valves 88/6, or add 5/10 to deposit and monthly payments.

**KIT BITS.** Supplied in Kit A. Detailed price list on request.  
Specified Peto-Scott drilled chassis. 7/9.  
Specified J.B. Linacore Tuner. 65/-.  
Specified Varley I.F. Transformers (2). 15/6.  
Specified Varley Mains Transformer. 37/6.

**AERIAL EFFICIENCY!** The congested state of the ether and the presence of man-made interference make the use of a Peto-Scott All-Wave Anti-Noise Aerial essential for reliable all-wave listening. 17/6 only cash or C.O.D. or 8 monthly payments of 2/6.

**PETO-SCOTT CO., LTD.**  
77 (Pr. 47), City Road, London, E.C.1. Tel. Clissold 9875.  
41 (Pr. 47), High Holborn, London, W.C.1. Tel. HOLborn 3248.

SEND FOR LISTS

**FOR SHORT-WAVE RESULTS**

You need a T-R-O-P-H-Y!



**TROPHY 8.** All-British 8-valve A.C. communications type receiver. Wave-range 7-550 metres, continuous band spreading. Switched A.V.C. and B.F.O. Stand-by switch. Phone jack. For use with separate speaker. Cash, C.O.D. 12 mos. or 15/6 down and 18 monthly payments of 15/6. **15/6** down 12-month guarantee includes valves.

**TROPHYS from 25.15s.**

A NEW BOOK OF SPECIAL INTEREST

**PHOTOGRAPHY for PROFIT**

By "NETTEL"

*The most authoritative work yet produced on the money-making potentialities of the still camera.*

A BRIEF OUTLINE OF THE CONTENTS:—  
Landscapes and Views. Advertising Photography. Press Photography. Caption Writing and Placing Photographs. Competitions. Sidelines and Useful Tips. Lenses and Stops. The Law of Copyright. Classified List of Markets.

**OVER 60 HELPFUL PHOTOGRAPHIC ILLUSTRATIONS**

**5/- NET (By post 5/6)**

From all Booksellers, or by post from the Publishers  
**GEORGE NEWNES, LTD. (Book Dept.),** Tower House, Southampton St., Strand, London, W.C.2.

**J. B. "LINACORE"**

**Simplifies All-Wave Superhet Construction!**

The J.B. "LINACORE" is an ALL-WAVE TUNER designed with the definite idea of producing a highly efficient unit in a simple and economical form.

**Specified for the 1939 ALL-WAVE SUPERHET described in this issue**

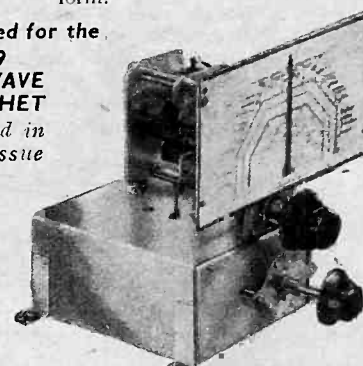

A J.B. PRECISION PRODUCT

Every unit is accurately aligned before leaving our factory.

The Tuner is made in two types. Model AW for A.C. Mains and Model AWB for Battery operation.

Price for either model, complete as illustrated **55/-**

Send for our latest Lists of Condensers and Dials and full details of LINACORE Tuner.



**JACKSON BROS. (London) LTD.**  
72, ST. THOMAS STREET, LONDON, S.E.1

**● AROUND the SALES**

**INFORMATION that SAVES you MONEY!**

If you're after an AC All-wave 4-valve Superhet Chassis—fully tested and complete with valves—there's an excellent N.T.S. bargain going at £2 12/6: you get a free matched speaker by the way, and 5/- secures the lot, balance in 16 monthly payments of 7/-. My advice to battery users is secure the N.T.S. All-wave SG 3-valve Battery Chassis model 7032, marked down this week at 47/6 (less valves) or 62/6 with British valves: 5/- deposit again secures. Amazing Bargains these.

Don't miss these Amplifier offers: 70/- (or 5/- deposit) only, buys a 7-watts AC model from N.T.S., built on a steel chassis and four valves fitted. If you must use a battery amplifier, invest in a 4-watts output model going complete at 55/- or 4/- down. Recommended lines for Public address work.

Kit with valves given free! Owing to the increase in short-wave listening, the N.T.S. Bandsread 4-valve SG-Pentode output model is a good "buy" at 49/6 or

Tested Receivers

**MR. CAMM CONFIRMS!** Pentakit Receiver is an admirable performer, with no instability." You know perhaps that this marvellous-value kit provides for building a 1-, 2- or 3-valve 9 to 2,000 metre receiver or short-wave Adaptor or Converter. Kit, coils and three valves costs 42/- or 2/6 deposit and 12 payments of 3/9.

3/6 down and 12 at 4/3. Or, for headphone use only there's the N.T.S. One-Valve with 'phones at 27/6 or 2/6 down: both kits mentioned are supplied with coils for 12 to 94 metres. You should certainly go in for a WORLD All-wave Kit. The 3-valve SG model is a snip at 29/6 or the more powerful WORLD SG4 is bargaining off at 42/- or 2/6 down and 12 monthly payments of 3/9. Complete set of WORLD self-locating coils for 9 to 2,000 metres, costs 17/6 (add 1/6 to payments only). Don't forget you get FREE valves and station-name scale with all WORLD Kits.

Wish I had space to give all N.T.S. equipment bargains but note these: complete Cosmovald Pickups, 6/6. 2-gang .0005 mfd. condensers, 2/3. AC 2-volt 1-amp. trickle charger 10/- and the famous N.T.S. Bargain parcel at 6/6 post free, all really amazing offers.

**FREE** The following catalogues post free on request: 1938 Bargains, Chassis, Kits, Amplifiers, Valves and the N.T.S. revised Short-Wave book. N.T.S. cash prices are the lowest and Terms are the easiest.

**NEW TIMES SALES CO.**  
58 (Pr. W46), LUDGATE HILL, LONDON, E.C.4  
Phone: City 5516. Est. 1924.

# Relays and Phone Broadcasting

Report of Speech by the Postmaster-General, Major the Rt. Hon. G. C. Tryon, M.P., in the House of Commons on Friday, June 16th

THE following is a report of the main portions of the P.M.G.'s speech relative to the position of Relay Companies and the new 'phone broadcast system:

"I understand that at the request of the Opposition, the Committee will be discussing to-day the subject of wire broadcasting. This, of course, includes the problem of the Relay Exchanges.

"The House will, of course, be familiar with the Relay Exchanges which exist in many parts of the country for the purpose of receiving broadcast programmes and distributing them over a local wire network to subscribers. The phrase, 'Wire Broadcasting' is used in a wider sense to include any and every method of distributing broadcast programmes by wire to subscribers. That is, it includes both the Relay Companies' system and the proposed telephone broadcasting system.

"Three years ago this House approved the Government's decision that the licences of the Relay Companies should be extended for a further three years and that meanwhile the Post Office should undertake technical research and practical experimental work in distributing broadcast programmes by wire. Since then the position has changed in several very important respects. In the first place, technical research and practical experiments carried out by the Post Office have established the possibility of providing a wire broadcast service of high quality over our telephone wires without interfering with their normal use for telephone purposes.

"I now come to an even more important change which has occurred since we last debated this matter—the change in the international situation. This has led to a greatly increased recognition in all quarters of the importance of defence considerations and of the imperative necessity of doing everything possible to expedite defence measures. . . . The Ullswater Committee which considered the question of the future of wire broadcasting in 1935 made no reference in its Report to its importance from the point of view of national defence.

"As I informed the House on March 30th last the main consideration which led the Government to decide that the public interest would best be served by the development of both the Relay Companies' services and a Post Office telephone service, was its importance from the point of view of national defence and national safety.

## Value in Time of War

"The Government recognised—as I think everyone in this House will recognise—the very great value of broadcasting in time of war, as a means both of communicating information of vital importance to the public and of maintaining morale. As I also said, although it is the intention that wireless broadcasting should be continued in the event of war, the wireless broadcasting service will be liable to deterioration or occasional interruption as a result of interference from which a wire service would be immune. The Government, therefore, came to the conclusion that it was important that wire broadcast-

ing should be developed to the maximum possible extent.

"In our earlier debates on this subject, the discussion centred round the question whether wire broadcasting should be exclusively conducted by the Relay Companies or by the Post Office. The Government, however, in reviewing the matter in the light of present-day circumstances, realised that the vitally important objective of securing the maximum possible degree of development would only be achieved by employing the resources of both the Relay Companies and the Post Office.

"It recognised on the one hand that the Relay Companies possessed important resources in the form of operational experience and technical skill as well as of physical assets, which would enable them, given reasonable security of tenure, to make a valuable contribution towards the achievement of this objective. At the same time it recognised that the Post Office, with its extensive network of telephone wires and its highly skilled engineering staff, was in an exceptionally favourable position to provide a complementary service over the telephone wires.

## Tax on Resources

"At the present time the resources of the Post Office are being heavily taxed to meet the very great demands made upon it for the provision of telephone service for the defence services and to keep pace with the unprecedented expansion of the public service which has resulted from the progressive reductions of charges made in recent years. Its resources will be further taxed in the provision of the new telephone broadcasting service.

"It reflects no discredit on the Post Office to say that if it had at the same time to take over the separate-wire systems of the Relay Companies, wire broadcasting could not expand so rapidly as under the Government's proposals. On the contrary, the maximum rate of development will be ensured by the Government's decision to leave the Post Office to concentrate on the development of a system of wire broadcasting over telephone lines and to encourage the Relay Companies to expand their system.

"Before I proceed to deal with the Government's proposals in greater detail, there is one very important subject on which I should like to say a few words. I have shown that the Government attaches great importance to the development of wire broadcasting for defence purposes, and for this reason is particularly anxious that the Relay Companies should expand their activities as rapidly as possible. To this end the Government hopes that the Companies will establish relay services in fresh areas as soon as possible.

"The Government, however, has no power to grant Relay Companies the wayleaves which they must have before they can put up their distribution wires. It rests with the local authorities to give or withhold the necessary facilities.

"It has come to my notice that in a few cases local authorities have refused to allow the establishment of relay services in their areas. I should like to make a special appeal

to local authorities to co-operate in this work of national importance, by satisfying themselves first that applicants are, suitably qualified technically and financially, and then giving expeditious and sympathetic treatment to their requests for the necessary facilities.

## Details of the Government's Proposals

"In giving details of the Government's proposals, I will deal first with those that affect the Relay Companies. The function of Relay Companies' is to distribute programmes from recognised broadcasting stations and not to originate broadcasts themselves.

"As I informed the House on March 30th the Relay Companies' licences will be extended for a further period of 10 years from January 1st next, subject to certain modifications regarding the programme supplied to subscribers and the control of exchanges in time of emergency. Licences granted to new Companies will also be terminable on December 31st, 1949, and will be subject to similar conditions.

"The new licences will require that all existing services which give at present more than one programme, and all services opened in future, will have to offer a choice between at least two programmes. Furthermore, provision will be made for a definite percentage of B.B.C. programmes to be provided.

"(a) Existing one-programme services will have to provide a B.B.C. programme for at least 90 per cent. of the total time during which such a programme is available.

"(b) Two-programme services will have to provide a B.B.C. transmission on one programme at all times when it is available and in addition a second B.B.C. transmission for at least 75 per cent. of the total weekly time when two B.B.C. programmes are available.

"(c) Services giving more than two programmes will have to provide two B.B.C. programmes when they are available, or one B.B.C. programme when only one is available.

"Outside these limits, the Companies will be free to give what programmes, including advertising programmes, they like subject to the continuance of certain safeguards contained in the present licences. For example, the distribution of programmes containing religious, social or political propaganda in English from abroad is, and will continue to be, prohibited. The new licences will contain a provision enabling the Postmaster-General to require a Relay Company to lease wires at a suitable rental for the purpose of obtaining programmes from B.B.C. studios entirely by wire.

"The value of this provision in time of war when wireless reception may deteriorate or be subject to occasional interruption or interference, is obvious. Details of this arrangement are being worked out and will be discussed with the relay organizations. So far as control in time of emergency is concerned, the new licences will provide that the Postmaster-General may require the working of the exchange to be continued

(Continued on facing page)

**RELAYS & 'PHONE BROADCASTING**

*(Continued from previous page.)*

under his direction or subject to his instructions as regards the matter to be relayed.

"Provision will also be made enabling the Postmaster-General to require the Relay Exchanges in time of emergency to transmit any special announcements ordered by the local A.R.P., National Services or Police Authorities—this was done during the crisis last September.

"In this connection I should like to mention that I have received several applications from local National Service and A.R.P. organisations for permission to make announcements over the local relay exchanges in present circumstances. Similar requests have been received in the past for permission to relay charitable appeals.

"As I have said the function of the Relay Exchanges is to distribute programmes from recognised broadcasting stations and not to originate programmes themselves. In other words, they are concerned with the receiving and not with the transmitting side of broadcasting. There are obvious dangers in allowing them to extend their activities to the originating of broadcasts. It has, therefore, been the practice to refuse all requests for permission to distribute local announcements through the local relay exchanges in normal times.

"When I received some applications for permission to relay National Service appeals and the like, I thought it only right to consult the Departments responsible for A.R.P. and National Service publicity—the Lord Privy Seal's Department and the Ministry of Labour—as I felt that I must be guided in a matter affecting the whole country by their views. The conclusion was reached that the advantages were not sufficient to justify a departure from the rule in the prevailing circumstances.

**Telephone Broadcasting**

"I come now to the proposed Post Office Telephone Broadcasting Service for which a Supplementary Estimate will be required. Under this service a subscriber will be able to receive broadcast programmes over his telephone and will be able to telephone at the same time as his receiving-set is in use. This system differs from the separate wire system used by the Relay Companies in an

important respect. Under the Relay Companies' separate wire system, the listener only requires a loudspeaker.

"Under the telephone broadcasting system, the listener will have to have a receiving-set the same as—or similar to—those already in use for ordinary wireless reception. Indeed, he will be able to use his set as he wishes, either for ordinary wireless or for wire broadcasting, with its very much higher quality of reception and its freedom from interference. The new telephone broadcasting service will not, therefore, reduce the demand for receiving sets.

"I understand that the radio trade is prepared to supply and maintain receiving sets of special design which will enable the best use to be made of the telephone broadcasting service. On the assumption that these arrangements will prove satisfactory, I propose to start the service on the basis that all sets used by subscribers will be supplied and maintained through the usual trade channels. It follows, therefore, that the Post Office telephone broadcasting service will not compete with the radio trade.

"It is proposed at the outset to offer the Post Office service to telephone subscribers only. It would be technically possible to extend to non-subscribers, and the question of extending it in this way will be reviewed later. As regards programmes, it is proposed on the telephone broadcasting service to give a choice of three or four programmes, including the B.B.C. National and local Regional programmes at all times when they are available.

"The Post Office is in consultation with the B.B.C. concerning the arrangements to be made for the selection of continental programmes to supplement the B.B.C. programmes.

"As I told the House on the 30th March last, the service will, I hope, be started this year in a few districts and the charges and other details will be announced in due course. I am now able to tell the House that I hope about the end of this year to make a start with a Post Office telephone broadcasting service covering the Central London area and practically the whole of Edinburgh, Birmingham and Manchester.

"The charge for this service is not yet fixed, but I hope that it will be possible to make it less than 1s. a week. This does not include the receiving set, which in most cases the subscriber would already possess."

**TELEVISION AND SCHOOL LIFE**

ALTHOUGH the study of television and the use of receiving equipment has been included in the normal curriculum of several technical schools and colleges within the Alexandra Palace area, it is only of more recent date that the educational and interest items broadcast by the B.B.C. in their afternoon transmissions have been used by schools for instructional purposes. Those responsible for the training of the young mind realise that when there is an appeal to the eye as well as the ear the attention of scholars is arrested, and that is why television shows such a material advantage over the normal aural broadcasts to schools which have been undertaken for such a long period by the B.B.C. Headmasters have realised this, and when funds permit a set has been purchased and installed in the classrooms for the use of the boys and girls where the programme matter is suitable. A careful study of each week's programme reveals a surprising number of items which can be turned to educational account. Citizenship and general knowledge have been brought

home to both boys and girls through the medium of televised news reels, and outside broadcasts such as the Armistice ceremony, Trooping of the Colour, their Majesties' departure for America, etc. Then the series of talks from the farm near Enfield and the discourses on maps have proved invaluable to the child mind, which can very rarely form a true impression of things it cannot see. There is no doubt that as the television service extends the B.B.C. will give due consideration to the introduction of regular weekly items designed entirely for educational purposes, and this move will be welcomed by all progressive teachers who see in this new medium a means for supplementing lessons by specialists' talk and demonstrations.

**WIRELESS CONSTRUCTOR'S ENCYCLOPEDIA**

5/- or 5/6 by post from  
George Nennes, Ltd., Tower House, Southampton Street, Strand, London, W.C.2

For that little extra sensitivity —  
and that little extra top response —  
that slight extra 'forwardness' —  
that slight extra smoothness —  
which add so MUCH to your set's value,  
**FOLLOW Mr. CAMM'S EXAMPLE**  
**AND USE A**

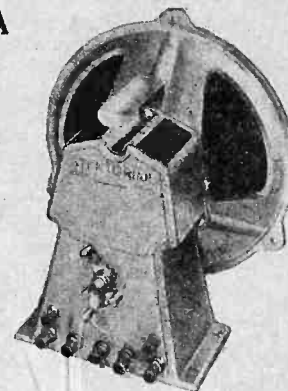

Chassis from 17/6. Ask your dealer.



**Stentorian**

The Universal Permanent Magnet Speaker  
WHITELEY ELECTRICAL RADIO CO., LTD.  
MANSFIELD, NOTTS.

**A Book to Read and Discuss**

**RUDE LETTERS TO YOUTH**

From **BILL BACK-BENCH, M.P.**  
including letters from  
**Bernard Joy, G. O. Allen,**  
**H. G. Owen-Smith**

introduction by  
**IAN HAY**

(Major-General J. H. Beith, C.B.E., M.C., Director of Public Relations at the War Office)

Illustrated by **BATEMAN**

Pertinent comments on contemporary matters, including Conscription, Compulsory Physical Training, Uncollective Insecurity, Capitalism, Nazism, Fascism and Communism.

**WHAT THE PRESS SAYS**

"Provides a live commentary upon the controversial politics of the hour."—*Daily Telegraph*.  
"—A naiveté which endears the author no less than it delights the reader."—C. E. M. Joad, in *The Spectator*.  
"—A very provocative book, frank, sensible, and cogent."—*Sunday Times*.

**2/6 NET**  
(By post 2/8)

Proceeds of the sale of this book will be given to the National Playing Fields Association.

Available at all Booksellers or by post from the publisher, C. Arthur Pearson, Ltd. (Book Dept.), Tower House, Southampton Street, London, W.C.2.

# LETTERS FROM READERS

The Editor does not necessarily agree with the opinions expressed by his correspondents. All letters must be accompanied by the name and address of the sender (not necessarily for publication).

## Correspondents Wanted

SIR,—I have been a regular reader of your extremely fine paper for about one year, and I certainly intend to stick to it because I always find interesting features in it.

I don't know too much about radio, but I am very keen on it. I should be very pleased if you would put me in touch with any of your readers residing in North Africa, South America or Egypt or elsewhere, preferably outside Europe.

I also should be very glad to exchange my S.W.L. card with anyone interested.—RAGNAR A. ANDRESEN, Krokettønnen, Drøbak, Norway.

SIR,—I have been a reader of your book for one year, and I have always been interested in your short-wave logs, so I submit mine to you.

From May 1st-20th: 14 mc/s: W1QM, 1AJW; 1BLQ; W2DIQ, 2DH, 2EZI, W3AL, 3BEI, 3GFG; W4DIS, 4DIF, 4DI; W5CDD, 5CZ; W7GEA; W8OPD; W9EJT; ZB4AI, EA7BA, CY4FT, PY4EJ, PY5BL, CX2CO, VQ2PM. I should also like to correspond with a boy living in U.S.A. interested in S.W.L. I wish your book all the success in the future.—GORDON ZEDY, 6, Norfolk Park Cottages, Maidenhead, Berks.

SIR,—I have been a reader of the PRACTICAL AND AMATEUR WIRELESS since the first issue, and I find your articles very interesting. I am very anxious to correspond with any S.W. enthusiast in any part of the world. Every success to your fine paper.—F. H. LADD, Harold Court, Harold-wood, Essex.

SIR,—Here is my complete log of 20-metre phone amateurs, started on January 6th, 1939, to May 26th. My listening hours were varied: W1, 64; W2, 51; W3, 30; W4, 31 (W5DNI, GYH); W6, 7; W8, 22 (W9MM, NER, ASK, RUK); VE1, 10 (VE3LL, QL, HG, XQ); VO2N; CT2BP (CO2WM, AM, JJ, 3HY, 7EV, 8AR; (VP9L) (CP9AM) (CP2CP) (HH2B); PK1RI; VK2AGU, VU2FQ (ZB1L, E) (CN8MB, MT, BA, MI, AR); FA3FB; EK1AF (SV1CA, MP, KE) (SU1, 7; 5BO); CT1, 20; II, 11; HB9, 7; YU7VX (YR5PB, VV, AA); HA, 7; PA, 6 (OK1SZ) (SP1QE, 2OE); SM, 13 (ON4USU, LP); ES5C (LY1AA, S); LA, 10; F3, 16; F8, 7; LXTW; OH2QM; OZ, 6.

My latest calls are: YV1AQ, 4AE, 5ABQ; VP3CO (PY2BH, BN, PY1GR, PY4??); LU5CZ; ZP2B; HR5C (TI2RC, AV); CX2CO; CE3AT; K4EJF; VQ26M, all during the last week 22.45-23.45 B.S.T.

The above was received on a battery-3 (except VK and PK) reception on phones; my aerial is the inverted "L" type, 60ft. long, 4ft. from the ground free end, rising to 28ft.

I would like to get in touch with a reader

living around my district, interested in C.W., as I would like to learn it, and if any reader in U.S.A. would like to correspond with me on S.W.L. and exchange news and magazines.—T. DUMAYNE, BSWL 1137, 65, Gaer Park Avenue, Newport, Mon.

## A 40-metre Log

SIR,—I have been a regular reader of PRACTICAL AND AMATEUR WIRELESS for some time now, and I have been very interested in the short-wave logs submitted by readers each week.

Perhaps they would be interested in a 40-metre log that I received on Sunday morning, between 10.45 and 11.20 a.m.

My receiver is an 0-v-1/2 with a vertical aerial of 25ft.

W3DAJ, 4DIA, 2DL, G4IK, G3RK, W26S, G5FA, G5IT, G4IP, CT2AB, G2PU, G8IT, G5MM.

Besides the usual Americans and Europeans. I also find that in my case a power valve is better than a pentode output.—A. SIMONS (Newton Abbot).

## 14 mc/s Log

SIR,—Not having seen a log of stations from this district, may I submit my 14 mc/s log, which may be of interest to other readers: W1(33), W2(25), W3(17), W4(14), W6(8), W8(18), W9(5), VE(21), VK(8), VU(5), PY(17), CO, CM(8), YV(5), LU(4), SV(5), ZS(15), CX(3), CE(4), KA(3), J(2), SU(19), VQ2(2), ZEI(2); also VQ4KTB, K75ST, HP4DF, K4FAY, VP9L, PK4JP, H13N, V8TRA, VP3CO, FNIC, ZP6HF, ZC6HS, K6MYV, VP5CF, CT2BP, 17B (located in Asmari in Ethiopia), W6 has been coming in well around 06.00-09.00 G.M.T. the last fortnight. I use a 2-valve set with a 60ft. inverted L. Good luck to your fine paper.—C. W. SPENCER (Loughborough).

## Card Exchange

SIR,—I would like to exchange my S.W.L. card with other S.W.L. throughout the world. I will reply to every card. ROBERT D. PITTLO (BSWL776) "Wansfell," Queen Margaret St., Kinghorn, Scotland.

# Radio Clubs and Societies

Club Reports should not exceed 200 words in length and should be received First Post each Monday morning for publication in the following week's issue.

**WOODFORD AND DISTRICT RADIO SOCIETY**  
Secretary: Mr. R. A. Ledgerton, (2ABC), 64, High Road, Woodford Bridge, Essex.

Meetings: Every Tuesday.

THE above society, which has recently been formed, held its first meeting on June 20th. A committee was elected, including Mr. John Hunt (2FSR) as chairman, Mr. R. A. Ledgerton (2ABC) as secretary-treasurer, and other A.A. licencees and short-wave listeners.

The aim of the society is to foster interest in short-wave radio, and to provide members with an opportunity of meeting and discussion, special attention being paid to Morse. It is also hoped to build a society receiver and transmitter, and to organise listening contests.

All radio enthusiasts in the district are cordially welcomed, and the secretary will be pleased to forward further particulars to anyone interested.

**COXHOE AND DISTRICT AMATEUR RADIO SOCIETY**

Headquarters: Slake Terrace Inn, West Cornforth, Co. Durham.

Secretaries: D. F. Chatt, 23, North View, Sherburn Hill, Co. Durham. R. Bowes (2DTA), 10, Blackgate, Coxhoe, Co. Durham.

Meetings: Fortnightly at present. Under discussion.

A MEETING was held on Monday, June 19th, at the above H.Q. at 7.30 p.m. In the absence of Mr. Ayton, Mr. D. F. Chatt gave some Morse instruction, and Morse practice is becoming quite popular. Mr. W. Bates gave some instruction to beginners on the use of various components in the club receiver. The future course was discussed and it was decided to build the following apparatus for beginners.

(a) An O.V.O. receiver. (b) An L.F. amplifier for the O.V.O. receiver.

A committee meeting was called to further discuss the programme and also to arrange the times for meetings.

Further particulars may be obtained from the secretaries.

**SALE AND DISTRICT RADIO SOCIETY**

Headquarters: St. Mary's Schools, Barkers Lane, Sale, near Manchester.

Secretary: S. C. O. Allen (2FCQ), 31, Ennerdale Drive, Sale.

Meetings: Held weekly at 7.30 p.m.

MR. NORMAN POSTLES (2CXH) continued his series of lectures at the last meeting with an explanation of the Tuned Plate-tuned Grid and Crystal Controlled Transmitters. The operation of these circuits was considered and methods of tuning were fully covered. Mr. Postles pointed out that for amateur purposes crystal-controlled transmitters were essential unless elaborate frequency measuring instruments were available.

The Hon. Treasurer of the society (Mr. G. E. Taylor) has been allotted the call sign 2HDB.

Readers of PRACTICAL AND AMATEUR WIRELESS who are interested in amateur radio transmission and reception will be welcomed at any meetings of the society. Subscriptions: sixpence per week, with an entrance fee of one shilling.

**BRISTOL EXPERIMENTAL RADIO CLUB**

Headquarters: 21, King's Corridor, Old Market Street, Bristol 2.

Publicity Manager: D. J. James (2DCX), 40, Robertson Road, Eastville, Bristol 5.

Meetings (Summer Season): Second Tuesday of each month at 8.0 p.m.

AT the meeting of the above club held at headquarters on Tuesday, June 6th, a selection of amateur communication receivers was described and demonstrated. These included an Eddystone "All-World Two," a Hallicrafter "Sky Chief," and a Meissner fourteen-valve superhet. The latter was of special interest, as it was home-constructed by a club member, Mr. A. Taylor. Although one section of this set had not been completed, excellent reception of American short-wave broadcast stations was obtained when using only a short length of flex as an aerial.

Arrangements were made for the first Club "Field Day" held on Sunday, June 11th. On this date a party of nine members with three receivers visited Dundry, and another of six members with two sets went to Penpole Point. A fairly good log of American and European amateur stations was obtained by each group; all those present had a very enjoyable afternoon and there were many requests that a "repeat performance" should be arranged as soon as possible.

The next meeting will take place on Tuesday, July 11th, when G3YT will demonstrate his transmitter and details of a suggested visit to the operating box of a local cinema will, it is hoped, be announced. All those interested are invited.

# Music of the Week

**EVERYONE**, no matter in which direction his own particular tastes may lie, instinctively admires someone who has achieved indisputable success in another line. And with success, popularity. A thousandth broadcast is an event which few will ever be called upon to perform, but this remarkable feat is being done by Reginald Foort on the B.B.C. Theatre Organ on July 9th. His programme is made up of suitable "memories of the

## Criticism hat & Comment

By MAURICE REEVE,  
The Famous Radio and Concert  
Pianist.



A recent portrait of Mr. Maurice Reeve.

past." Let's all listen-in to it and congratulate him.

Another "Music Bee" is down for the same day, and also a concert by the B.B.C. Midland Orchestra under W. K. Stanton. During the close season in the concert world the B.B.C. Symphony Orchestra, their star performers, are not unnaturally taking a well-deserved rest. The arduous nature of their labours from mid-August till June is sufficient to compel this brief respite. Consequently the duties of providing us with studio programmes devolves on the excellent regional orchestras. They are all on this week from their various studios, and are giving us some really good programmes. It is usually the job of the Regional orchestras to play the excellent music for which the main orchestra hasn't the time. One will always find most interesting works, sometimes very seldom heard, in their programmes, and next Sunday's, which includes Chabrier, Boccherini, Dvorak and Grainger, is no exception.

The last two broadcasts from Glyndebourne, where the audience spends the intermission strolling about the beautiful lawns and shady groves surrounding the opera house, are, on the 9th and 13th, Act 1 of Mozart's "Magic Flute" and Acts 1 and 2 of Donizetti's "Don Pasquale" respectively.

### Schubert's Songs

Although Schubert's songs are often enough heard, we seldom have the oppor-

tunity of listening to his cycles in anything like their entirety. One of these, "The Fair Maid of the Mill," should not be missed on the 11th, especially as it is being sung by Keith Faulkner. Schubert discovered them in a book called "Poems found among the Papers of a Travelling French Horn Player," one Wilhelm Muller. So successful were they that he turned to the same source for the even greater set, "Die Winterreise."

A welcome return to the studios is made on the 13th by the Edrice Cundell Chamber Orchestra—leader, Carl Taylor. Mr. Cundell got his orchestra well under way before he was made Principal of the Guildhall School of Music. The programme contains the type of work just mentioned as usually appearing in the programmes of either the Regional or visiting orchestras: Schubert's 5th Symphony, a beautiful work from his early twenties.

Music libraries may sound rather stuffy and not made of very entertaining material, but my interest, at any rate, has been aroused by an item down for the 13th, a description of the library of St. Michael's College, Tenbury, one of the most famous private collections in the world. When it is learnt that the manuscripts include that of the "Messiah," that W. K. Stanton will conduct the strings of the B.B.C. Midland Orchestra in illustrations to the Rev. Canon E. H. Fellowes' talk on the library, of which he is the librarian, it should be agreed that a most satisfactory half-hour is in store for us.

### The Harpsichord

The gay and chivalrous old-world is nowhere more perfectly symbolised than in the "Sonatas" for harpsichord of old Domenico Scarlatti, 1683-1757. All the grace and charm of that fast-receding world are contained in the 500 examples in the Longo edition. Our curiosity is awakened by the news that four unpublished examples, together with one with violin, will be performed by Richard Newton and Lionel Salter from Mr. Newton's home at Yardley, Birmingham, on the 14th. No previous performance of them has been traced. The performance will be given on Mr. Newton's own harpsichord.

Mr. Victor Hely-Hutchinson is known as one of the best of the younger British musicians, and he has done crowds of good work for the B.B.C. in London and Birmingham. On the 14th he is conducting the Midland Regional Orchestra and singers in a concert of his own compositions.

The story of how Beethoven wrote some of the world's greatest musical masterpieces, either when partially or totally deaf, is the story of one of the Wonders of the World. The whole of Beethoven's life, in fact, is so packed with drama and incident that it is strange it should not have been made into a play as successful as were the "Damask Rose" or "Lilac Time." On the 9th, however, the omission will be partly repaired, at least, when a version of Arthur Watkyn's "Muted Strings," first produced by the Birmingham Repertory Co., will be brought to the microphone. It should afford an absorbing entertainment as it sets out to tell the story of the years when the Master, only just over thirty, first realised that the impairment of his hearing would be a life-long affliction. More next week.

## ELECTRADIX BARGAINS

### Summer Redecoration Sale !!!

We are having a rapid clearance sale to clear goods from our Stores at rubbish prices, as space is needed.

**TRANSMITTERS.** Aircraft 2-valve, old type R.A.F., with valves, 17/6. Field Transmitters, old Army type, 1 and 2 valve, portable, totally enclosed with Valves, folding key and aerial meter, 40/-. Sullivan variable R.F. inductances, 7/6. A.C. Hand Generators, P.M., geared drive, 80 volts, 20 m.a., 5/-.

**100 ELECTRIC DRILL STANDS.** Massive Wolf polished Steel Stand, Geared rise and fall with counter-weight. Suitable large or small machines, 7/6, carr. fwd.

**MORSE PRACTICE SETS.** No. 3, with key buzzer and lamp for sound and visual, line plug, etc., 7/-. Sound Type, 1A type key and buzzer, 3/-. Visual Type 2A, key and lamp, 2/-.  
No. 4

**ONE HUNDRED** 10-watt Moving Coil Magnets by Darwin. New 4-claw 4lb. weight, 4s. each, post 1/-.

**5,000 RESISTORS.** 1 and 1 watt, 0.1, .025, .05, 1, 5 and 1 meg. Glass vacuum, wire ends, worth 1/- each at 1/- per doz., or 9/- gross.

**400 VARIABLE CONDENSERS,** single, .005 mfd. Tokade, 1/3. .005 S/W Formo, 2/-, 2-gang, 2/6. 3-gang, 3/6.

**200 EARTH** ground spikes for radio or telephones, 6/- doz., carr. fwd.

**60 NEW 3-VALVE** unwired Battery Sets with oak cabinet, aluminium panel, lettered, fitted 2 varia. condensers 13 x 7 x 6. Suitable A.R.P. valve or crystal set, 10/-, 2/- post and packing.

**X-RAY TUBES.** Brand new W.D. pattern, cost 5 gns., 10/- each. As we must clear these quickly for the room, 2/6 packing.

**Marine Type Switchboard** with Ammeter, maximum and minimum Auto. Cut-out Mains Switch and Fuses, Field Regulator, 25/-.

**MOTORS! MOTORS!** Tiny, Small and Medium horse-power. We have a large stock of really high-grade Motors, at low prices for immediate delivery. Battery Motors, A.C. Mains Motors, 100/250v., D.C. Mains Motors, 50/250v., at prices from 15/-.

**DOUBLE CURRENT DYNAMOS.** 6v. and D.C. 600 volts 100 m.a., 32/6. 7-watt P.M. model, 35/-; 15-watt 220 D.C./220 A.C. ball bearings, lam. field, silent running, enclosed, 65/-.

Latter sizes 50 watts, 100 watts and 200 watts to 3 kw. M.G. Sets D.C. 220v. to 6v., 5 amps., 65/-.

**MICROPHONES AND PARTS.** "W.W." No. 11 TABLE MIKE. A splendid Microphone for speech and music. Bakelite case, containing a 2in. transmitter and transformer on bronze pedestal, detachable Switch and plug. Unrivalled for quality and price, 15/-.

Other types: Lesdix No. 10B Pedestal, 10in. high, 12/6; Lesdix Superior No. 12BB Ring 14 in. Pedestal, 18/6; Hand Mikes in 2in. case, No. 11 at 5/6; Superior type No. 11A, 7/6. Buttons, 1/-; Eisel public address and hand Mike (Reisz principle), 55/-.

Ask for illustrated Mike List "W" of 25 models. Our Famous PARTS for making your own mike. Carbon Granules in glass capsule; Grade No. 2, 1/-; No. 3, fine, 1/6; No. 4, extra fine, 2/-; Black Blocks, 4d.; Diaphragms, thin carbon, 6d.; Buttons in 14 in. hard wood case with 2in. mica diaph., 2/6. Ditto mounted on pedestal, 3/6.

**METERS.** Weston model 334, Central zero 1 to 15 amps, pol. mag. Flush panel, 2in. dial. Sale price, 7/6. 0-20 volts, 5/9; 50 volts, 5/9; 0-100 volts, 5/9; 200 volts, 6/-; for A.C. or D.C. Hoyt CZ mov. coil milliammeters, 25-0-25 m.a., 10/-; Weston 0 to 30 m.a. mov. coil milliammeters, 17/6. 0-100 m.a., 17/6. Switchboard Meters all sizes, cheap.

**CAR CHARGERS.** From A.C. Mains for 5 amps., D.C., 24/7/6. Smaller Model for 2 amps. charge, 75/-.

**CHARGERS—WESTINGHOUSE** Metal Rect. Units, 110 volts 2 amp., 35/-; 55 volts 1 amp., 37/6; 29 volts 3 amps., 40/-; 9 volts 2 amps., 28/-.

The Lesdix "NITNDAYS" are the cheapest and best; reliable and for any mains voltage, 100 to 250 volts A.C.; steel chassis, Transformers and Westinghouse Rectifiers Model N/A 6/8 volts 1 amp. Car Trickle Charger, 15/-; Model N/B 6/8 volts 1 amp. Car Charger, 25/-; Model N/C 6/8 volts 2 amps. Car Charger, 38/-; Model N/D 12/15 volts 1 amp. Car Charger, 32/-; Model N/D 12/15 volts 2 amps. Car Charger, 55/-.

**THE FEIGH RECORDER.** Still a Few Left. Positive drive, worm gear and rack. Complete for use, only 37/6.

Super Feigh Fidelity Set, 42/6. Tracking Gear only 21/-. Either 4/- doz. metal blanks can be used or the glass-coated simplets, 10in. 3/- each. Pre-amplifiers for Recording Mikes, 1-valve Battery Model in cabinet, 25/-; A.C. Mains pre-amplifiers, with valve rectifier, steel-cased model, 60/-.

**GREAT BARGAIN** in 5/- PARCELS. 10lbs. of Servicing parts, resistances, tubulars, micas, variables, wire, sleeving, vol. controls, coils, magnets, chokes, switches, terminals, mouldings, etc.

**ELECTRADIX RADIOS**  
218, Upper Thames Street, London, E.C.4  
Telephone: Central 4611

For Everything that is new in Flying, Read—

# FLYING

The Popular Air Weekly  
Of All Newsagents and 3 D. Every Friday  
Bookstalls

FREE ADVICE BUREAU  
**COUPON**

This coupon is available until July 15th, 1939, and must accompany all Queries and Wrinkles.  
PRACTICAL AND AMATEUR WIRELESS, 8/7/39

# LATEST PATENT NEWS

Group Abridgments can be obtained from the Patent Office, 25, Southampton Buildings, London, W.C.2, either sheet by sheet as issued on payment of a subscription of 5s. per Group Volume or in bound volumes price 2s. each.

**Abstracts Published.**

**ELECTRIC SWITCHES.**—Compton Organ Co., Ltd., J., and Bourn, L. E. A. No. 499330.

In an electrical musical instrument wherein the partials of the notes are separately produced, vertical rows of contacts may be operated by the electromagnetic means shown in Fig. 1. The contacts consist of horizontal silver wires 1 whose free ends pass through apertures in insulating vertical slides 4 and project under bus-bars 2. Depression of a key energizes a magnet 5, the L-shaped armature 8 of which, loosely pivoted at its angle on a rib 13 and controlled by an adjustable screw-head 11, lifts the slide 4 against the action of a spring 10 and allows the wires to make contact with the bus-bars by their own resiliency. The wires 1 are connected to resistances 14 inserted in holes in the board 15. Specifications 403444, 433050 both in Group XXXVIII, and 501339 are referred to.

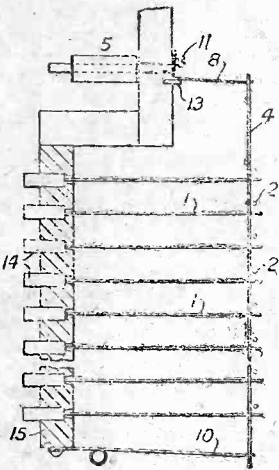

Fig. 1.

**ADJUSTING WIRELESS APPARATUS; GEARING.**—Marconi's Wireless Telegraph Co., Ltd., and Norwood, H. C. No. 501348.

Coarse and fine adjustment mechanism having a single operating-knob and a train of gears is provided with means operated upon endwise movement of the driving member for locking the gear train so that no slip occurs during gear change, a solid drive occurring during coarse adjustment. The knob C, Fig. 2, is held in position for fine adjustment by a light spring N, the drive being through gear D, F, D', J to the shaft M. The gear train is mounted between carrier plates E, H on which are formed friction surfaces engaging the knob C and fixed ring member G respectively. Endwise movement of the knob for coarse adjustment first overcomes spring N, closes clutch members E, C, and then opens the clutch parts G, H, the gear train driving solid with the knob.

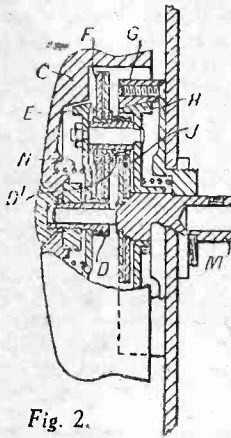

Fig. 2.

Relates to pick-ups and sound-boxes having means for protecting the stylus if the pick-up is dropped on a record or other surface, such means consisting of a member normally projecting below the point of the stylus and adapted, when the pick-up

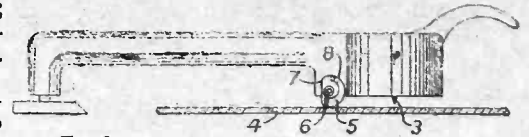

Fig. 3.

is placed on a record for playing, to be rotated so as to lower the stylus gently. According to the invention, the protecting device consists of a rotatable disc or roller 5, Fig. 3, pivoted so that it normally projects below the pick-up casing. The disc may, as shown, be pivoted at its centre 6 and be partially flattened at 7, a spring 8 so acting upon the disc that the circular part normally extends beyond the point of the stylus 3. When the pick-up is placed on a rotating record 4, the latter turns the disc 5 sufficiently to lower the stylus into engagement. A modification is described, in which the protective device consists of an eccentrically pivoted circular disc, weighted near its periphery.

Printed copies of the full Published Specifications may be obtained from the Patent Office, 25, Southampton Buildings, London, W.C.2, at the uniform price of 1s. each.

## A CHANGE OF FRONT?

THE Secretary of the Football Association, when expressing a personal opinion recently, warned football league clubs against the fear of innovations. He said it might not be wise for them to refuse to allow matches to be televised. The reason for this was the possibility of big-screen rediffusion allowing the clubs to claim an agreed percentage of the cinema takings when the televising of a match was undertaken. The same feeling seems to be growing in the boxing world, where there is a fear that actual attendance at a fight may be adversely influenced if television pictures are radiated for both home and public viewing. A readjustment of financial returns is always necessary when a new method of presentation is developed, and past history has shown that in the long run no one actually suffers. The position was ably summed up by Thermion, in a recent issue, in his usual trenchant and provocative style. Opposition only stimulates a new development to unexpected lengths to gain its ends, whereas co-operation brings a train of benefit, and a quicker settlement of differences with value to all concerned. All new inventions pass through the same phase, and yet we do not seem to benefit from past experience. Old industries that are in the least affected very often adopt a truculent attitude, refusing to give way a little because of the benefits they have enjoyed for a long period, but this has always proved to be a short-sighted policy. The public are always ready to try something new, and in television there is the essence of a new form of education and entertainment which may alter the whole outlook of life in general.

## NEW PATENTS

These particulars of New Patents of interest to readers have been selected from the Official Journal of Patents and are published by permission of the Controller of H.M. Stationery Office. The Official Journal of Patents can be obtained from the Patent Office, 25, Southampton Buildings, London, W.C.2, price 1s. weekly (annual subscription £2 10s.).

### Latest Patent Applications

- 16956.—General Electric Co., Ltd., Bligh, N. R., and Bloch, A.—Wireless heterodyne receiving apparatus. June 9.
- 16955.—General Electric Co., Ltd., Jacob, J. E. B., and Jesty, L. C.—Cathode-ray tubes. June 9.
- 16958.—General Electric Co., Ltd., Turner, H. C., and Tomlin, G. M.—Thermionic valve circuits. June 9.
- 17286.—Kolster-Brandes, Ltd., and Tiller, P. A.—Adjustment devices for radio-receivers. June 13.
- 16820.—Liguori, G.—Electromagnetic sound-recording, etc., apparatus. June 8.
- 17328.—Monge, G. de.—Television. June 13.
- 17275.—Scophony, Ltd., and Lee, H. W.—Television receivers. June 13.
- 16803.—Thornton, A. A. (Philco Radio and Television Corporation)—Detector coupling-circuits. June 8.
- 16804.—Thornton, A. A. (Philco Radio and Television Corporation)—Wide-band amplifiers. June 8.
- 16805.—Thornton, A. A. (Philco Radio and Television Corporation)—Synchronizing-circuits. June 8.
- 17261.—Thornton, A. A. (Philco Radio and Television Corporation)—

**GRAMOPHONES.**—Telefunken Ges. Für Drahtlose Telegraphie. No. 498963.

- Electrical discharge circuits. June 13.
- 17262.—Thornton, A. A. (Philco Radio and Television Corporation)—Power supply systems. June 13.

### Specifications Published

- 506911.—Ring, F.—Fluorescent screen arrangement particularly for television purposes.
- 507059.—McGee, J. D., and Lubszynski, H. G.—Television transmitting systems.
- 507144.—Kolster-Brandes, Ltd., and Smyth, C. N.—Combined apparatus for television reception and film projection.
- 507146.—Scophony, Ltd., and Okolicsanyi, F.—Television receiving-apparatus.
- 507181.—Marconi's Wireless Telegraph Co., Ltd., and Wright, G. M.—Direction-finding radio receivers.
- 506933.—Ferranti, Ltd., and Taylor, M. K.—Electron beam discharge tubes.
- 506856.—Ferranti, Ltd., and Wood, H.—Television and like receiving systems.
- 506876.—British Thomson-Houston Co., Ltd.—Automatic frequency control circuits for radio receivers.
- 506877.—Toulon, P. M. G.—Television and like electric systems. (Addition to 497367.)
- 506977.—Lorenz Akt.-Ges., C.—Radio systems.
- 506987.—Naamlooze Vennootschap Philips' Gloeilampenfabrieken.—Radio-receivers comprising means for suppressing disturbances of short duration.

## WORKSHOP CALCULATIONS TABLES AND FORMULÆ

By F. J. CAMM

3/6, by post 3/10 from

George Neumes, Ltd., Tower House, Southampton St., Strand, W.C.2.

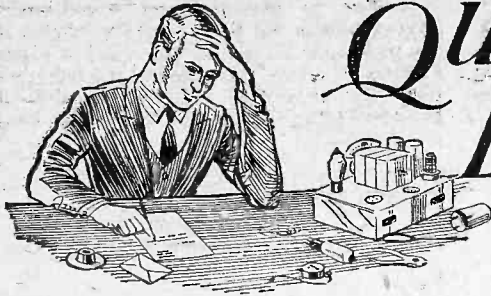

# QUERIES and ENQUIRIES

## Aerial Mast

"I should like to erect a fairly high mast in the garden and require about 40ft. My garden is, however, only 15ft. long, and I wonder what is the best way of setting about the mast. I anticipate having a transmitter eventually and, therefore, should like a reliable structure. Do you recommend the lattice type or a skeleton built from material such as 2in. by 2in. batten? Could you recommend any book on the subject?"—F. S. (S.E. 10).

THE ordinary type of mast has to be laid along the ground and hoisted into position, and this means that you would have to have an unobstructed 40ft. of garden space available for your proposed mast. In view of the restricted space we therefore suggest a lattice structure, made in sections. The top section should be placed on the spot where the mast is to stand and guy wires or ropes attached to the top and taken out to suitable anchor points. You will need assistance, and preferably should have someone at each guy point. Placing the

**RULES**

We wish to draw the reader's attention to the fact that the Queries Service is intended only for the solution of problems or difficulties arising from the construction of receivers described in our pages, from articles appearing in our pages, or on general wireless matters. We regret that we cannot, for obvious reasons—

- (1) Supply circuit diagrams of complete multi-valve receivers.
- (2) Suggest alterations or modifications of receivers described in our contemporaries.
- (3) Suggest alterations or modifications to commercial receivers.
- (4) Answer queries over the telephone.
- (5) Grant interviews to querists.

A stamped addressed envelope must be enclosed for the reply. All sketches and drawings which are sent to us should bear the name and address of the sender.

Requests for Blueprints must not be enclosed with queries as they are dealt with by a separate department.

Send your queries to the Editor, PRACTICAL AND AMATEUR WIRELESS, George Newnes, Ltd., Tower House, Southampton Street, Strand, London, W.C.2. The Coupon must be enclosed with every query.

sections handy, the top section should be lifted and the next section slipped beneath it. If the right material is used and the sizes are correct each section may be lifted quite easily. Bolt together, and lift the two sections and so on. Towards the end, owing to the weight, you may find that small pulley tackle is needed to lift, but three persons should be able to manage a well-constructed lattice mast provided that the guys are suitably held to prevent side sway. We do not know of any book on the subject, but we have published constructional details in the past.

## Stage Gain

"I am rather at a loss to know how to compute the gain of an L.F. stage where resistance-capacity coupling is concerned. I believe that the anode load should be as high as possible, but this in turn governs the anode current and, incidentally, the voltage drop across the resistance. On the other hand, an optimum load value is always given for an output valve. Why not for an L.F. valve? Perhaps you could help me on these points."—D. R. B. (Wealdstone).

THE anode resistance value must be chosen both in conjunction with the valve impedance and with the H.T. voltage which is available. Obviously an increase beyond a certain value will be of little use owing to the voltage drop, but the amplification of the stage is dependent upon the value of the load resistance, just as the output stage has to be matched, and most manufacturers give suitable values for the resistance.

## Battery Leads

"My receiver is battery-operated and I have a small cabinet which I wish to use. Unfortunately, there is only room at the top for the set and the batteries must therefore go down below. To make the appearance tidy I was thinking of taking H.T. and L.T. leads all together up the back of the set, but I wonder if this will lead to any trouble, or whether they should be well separated. Perhaps you could help me in this direction."—W. W. (Rotherham).

H.T. and L.T. leads may be bunched, and the only point to watch is that insulation is adequate to prevent short-circuits between the two sets of leads. To keep the appearance neat the leads should be laid side by side and tied with good twine in half-hitches throughout the length. It is also possible to place loudspeaker leads with these, but the aerial and earth leads should preferably be kept at the opposite side of the cabinet, and if the aerial lead has to cross over the speaker leads it would be preferable to allow a long length of wire for the lead-in, let this droop to the floor and then rise up to the aerial terminal.

## Stations Receivable

"I have received the blueprint No. A.W. 449, which illustrates the Twenty Station One-valver and I would like to know the names of the stations which the receiver will receive."—M. W. (Manchester, 9).

IT is not possible to give a complete list of the stations which formed the title of the above receiver as so much depends on local conditions, efficiency of aerial in use and such things as operating considerations. It is not a difficult matter, however, to receive more than the twenty stations, providing local conditions are normal. If the object of the question is to make a station-named dial, we would suggest that you select the most powerful stations received in your area and mark off a dial accordingly.

## Faulty Oscillator

"I have built a 5-valve all-wave battery-operated receiver which is perfect on all bands except the medium wave. On that section I can only get the local (Athlone 531 metres). Coils and everything else appear to be O.K."—P. J. F. (Co. Westmeath).

AS you do not give complete details of your receiver, we are unable to determine whether it is a straight employing ordinary H.F. amplification, or whether it is of the superhet type. If it is the former, we should imagine that some trouble must exist in the H.F. section, such as incorrect coil connections, instability, or a fault in the aerial tuning circuit. If, however, it is a superhet circuit, the trouble is no doubt in the oscillator stage, which we should imagine is not functioning on the particular band mentioned.

The coupon on page 405 must be attached to every query.

## World Time

"I find it very difficult to know when to search for certain long-distance signals. I am keen on getting an 'all-world' log, but the different times confuse me. Is there any book or table published which gives the equivalent times in different places, as most of the time tables I have seen give the actual station time and not G.M.T.?"—L. D. (N.W.5).

MOST programmes published in this country give G.M.T. or B.S.T. (British Summer Time). However, there is always a certain amount of interest in knowing the exact time at any given moment in various parts of the world, and although they may be computed from the World Map or Globe obtainable from Messrs. Webb's Radio, the Williss All-World clock is very much more useful as it is a standard time-piece and indicates G.M.T. or Summer Time, and enables the differences in various places to be seen at a glance. Correction for Summer Time may be instantly made in any part of the world.

## A.V.C. Circuits

"I wish to add A.V.C. to my superhet, which is a mixture of commercial and home-made apparatus. There are two I.F. stages and although a double-diode-triode is not fitted, I can easily re-wire the second detector stage to take this valve. Could you supply me with a suitable high-efficiency circuit for the purpose?"—N.M.W. (Belfast).

UNFORTUNATELY there are many types of A.V.C. circuit and, therefore, without a diagram or details of your receiver, and full details of the type of set you need, we cannot supply constructional or circuit data. In its simplest form A.V.C. would probably be of little use in a really high-class superhet. Amplified, delayed or a combination of these is to be preferred, and if the receiver is for short-wave use it may also be desirable to include a circuit which also gives noise suppression. We are, however, preparing an article on the subject, and this will be published within the next week or two, and we think this will assist you.

## Earth Connection

"The house into which I have moved has three-socket mains connectors, one socket being, I understand, an earth connection. Is this sufficiently reliable to warrant its use as an earth connection to my radio, and, if not, is there any way of getting a good earth as the building is let off in flats and I am on the upper floor, leading to a long wire to the ground level?"—L. W. (W.14).

THE earth pin may certainly be used as an earth point for your receiver and would no doubt give very much better results than would be obtained by a long lead running down to ground level, although the mains earth pin eventually has to go to earth. The connection from the mains supply is no doubt made to iron girders in the building or some similarly well-earthed metal body and, therefore, may be regarded as quite efficient from a radio point of view.

# Practical and Amateur Wireless BLUEPRINT SERVICE

These Blueprints are drawn full size. Copies of appropriate issues containing descriptions of these sets can in some cases be supplied at the following prices, which are additional to the cost of the Blueprint. A dash before the Blueprint Number indicates that the issue is out of print.

Issues of Practical Wireless	.. ..	Ad. Post Paid.
Amateur Wireless	.. ..	4d. .. ..
Practical Mechanics	.. ..	7d. .. ..
Wireless Magazine	.. ..	1/3 .. ..

The index letters which precede the Blueprint Number indicate the periodical in which the description appears: Thus P.W. refers to PRACTICAL WIRELESS, A.W. to Amateur Wireless, P.M. to Practical Mechanics, W.M. to Wireless Magazine.

Send (preferably) a postal order to cover the cost of the blueprint and the issue (stamp over 6d. unacceptible) to PRACTICAL AND AMATEUR WIRELESS Blueprint Dept., George Newnes, Ltd., Tower House, Southampton Street, Strand, W.C.2.

**PRACTICAL WIRELESS** No. of  
Date of Issue. Blueprint.

**CRYSTAL SETS.**  
Blueprints, 6d. each.  
1937 Crystal Receiver .. .. PW71  
The "Junior" Crystal Set .. 27.8.38 PW94

**STRAIGHT SETS. Battery Operated.**  
**One-valve : Blueprints, 1s. each.**  
All-Wave Unipen (Pentode) .. PW31A  
Beginners' One-Valver .. 19.2.38 PW85  
The "Pyramid" One-valver (HF Pen) .. 27.8.38 PW93

**Two-valve : Blueprints, 1s. each.**  
Four-range Super Mag Two (D, Pen) .. PW36B  
The Signal Two (D & LF) .. 24.9.38 PW76

**Three-valve : Blueprints, 1s. each.**  
The Long-range Express Three (SG, D, Pen) .. 24.4.37 PW2  
Selectone Battery Three (D, 2 LF Trans) .. PW10

**Sixty Shilling Three (D, 2 LF (RC & Trans))** .. PW34A  
Leader Three (SG, D, Pow) .. 22.5.37 PW35  
Summit Three (HF Pen, D, Pen) .. PW37

**All Pentode Three (HF Pen, D (Pen), Pen)** .. 22.5.37 PW39  
Hall-mark Three (SG, D, Pow) .. 12.6.37 PW41  
Hall-mark Cadet (D, LF, Pen, RC) .. 16.8.35 PW48

**F. J. Camm's Silver Souvenir (HF Pen, D (Pen), Pen) (All-Wave Three)** .. 13.4.35 PW49  
Genet Midget (D, 2 LF (Trans)) .. June '35 PM1

**Game Midget Three (D, 2 LF (Trans))** .. 8.6.35 PW51  
1936 Sonotone Three-Four (HF Pen, HF Pen, Westector, Pen) .. PW53

**Battery All-Wave Three (D, 2 LF (RC))** .. PW55  
The Monitor (HF Pen, D, Pen) .. PW61  
The Tutor Three (HF Pen, D, Pen) .. 21.3.36 PW62

**The Centaur Three (SG, D, P)** .. 14.8.37 PW64  
F. J. Camm's Record All-Wave Three (HF Pen, D, Pen) .. 31.10.36 PW69

**The "Colt" All-Wave Three (D, 2 LF (RC & Trans))** .. 18.2.39 PW72  
The "Rapido" Straight 3 (D, 2 LF (RC & Trans)) .. 4.12.37 PW82

**F. J. Camm's Oracle All-Wave Three (HF, Det., Pen)** .. 28.8.37 PW78  
1938 "Triband" All-Wave Three (HF Pen, D, Pen) .. 22.1.38 PW84

**F. J. Camm's "Sprite" Three (HF Pen, D, Tet)** .. 26.3.38 PW87  
The "Hurricane" All-Wave Three (SG, D (Pen), Pen) .. 30.4.38 PW89

**F. J. Camm's "Push-Button" Three (HF Pen, D (Pen), Tet)** .. 3.9.38 PW92

**Four-valve : Blueprints, 1s. each.**  
Sonotone Four (SG, D, LF, P) .. 1.5.37 PW4  
Fury Four (2 SG, D, Pen) .. 8.5.37 PW11

**Beta Universal Four (SG, D, LF, Cl. B)** .. PW17  
Nucleon Class B Four (SG, D (SG), LF, Cl. B) .. 6.1.34 PW34B  
Fury Four Super (SG, SG, D, Pen) .. PW34C

**Battery Hall-Mark 4 (HF Pen, D, Push-Pull)** .. PW46  
F. J. Camm's "Limit" All-Wave Four (HF Pen, D, LF, P) .. 26.9.36 PW67

**All-Wave "Corona" 4 (HF Pen, D, LF, Pow)** .. 9.10.37 PW79  
"Acme" All-Wave 4 (HF Pen, D (Pen), LF, Cl. B) .. 12.2.38 PW83

**The "Admiral" Four (HF Pen, HF Pen, D, Pen (RC))** .. 3.9.38 PW00

**Mains Operated.**

**Two-valve : Blueprints, 1s. each.**  
A.C. Twin (D (Pen), Pen) .. PW18  
A.C.-D.C. Two (SG, Pow) .. PW31  
Selectone A.C. Radiogram Two (D, Pow) .. PW19

**Three-valve : Blueprints, 1s. each.**  
Double-Diode-Triode Three (HF Pen, DDT, Pen) .. PW23  
D.C. Ace (SG, D, Pen) .. PW25  
A.C. Three (SG, D, Pen) .. PW29

**A.C. Leader (HF Pen, D, Pow)** .. 7.1.38 PW35C  
D.C. Premier (HF Pen, D, Pen) .. 31.3.34 PW35B  
Ubique (HF Pen, D (Pen), Pen) .. 28.7.34 PW36A

**Armada Mains Three (HF Pen, D, Pen)** .. PW38  
F. J. Camm's A.C. All-Wave Silver Souvenir Three (HF Pen, D, Pen) .. 11.5.35 PW50

**"All-Wave" A.C. Three (D, 2 LF (RC))** .. PW54  
A.C. 1936 Sonotone (HF Pen, HF Pen, Westector, Pen) .. PW56  
Mains Record All-Wave 3 (HF Pen, D, Pen) .. 5.12.36 PW70

**All-World Ace (HF Pen, D, Pen)** .. 28.8.37 PW80  
**Four-valve : Blueprints, 1s. each.**  
A.C. Fury Four (SG, SG, D, Pen) .. PW20  
A.C. Fury Four Super (SG, SG, D, Pen) .. PW34D

**A.C. Hall-Mark (HF Pen, D, Push-Pull)** .. 24.7.37 PW45  
Universal Hall-Mark (HF Pen, D, Push-Pull) .. 0.2.35 PW47  
A.C. All-Wave Corona Four .. 6.11.37 PW81

**SUPERHETS.**

**Battery Sets : Blueprints, 1s. each.**  
£5 Superhet (Three-valve) .. 5.6.37 PW40  
F. J. Camm's 2-valve Superhet .. 13.7.35 PW52  
F. J. Camm's "Vitesse" All-Waver (5-valver) .. 27.2.37 PW75

**Mains Sets : Blueprints, 1s. each.**  
A.C. £5 Superhet (Three-valve) .. PW43  
D.C. £5 Superhet (Three-valve) .. 1.12.34 PW42  
Universal £5 Superhet (Three-valve) .. PW44  
F. J. Camm's A.C. £4 Superhet 4 .. 31.7.37 PW59

**F. J. Camm's Universal £4 Superhet 4** .. PW60  
"Qualitone" Universal Four .. 16.1.37 PW73

**Four-valve : Double-sided Blueprint, 1s. 6d.**  
Push-Button 4, Battery Model .. 22.10.38 PW05  
Push-Button 4, A.C. Mains Model .. PW05

**SHORT-WAVE SETS.**

**One-valve : Blueprint, 1s.**  
Simple S.W. One-valver .. 9.4.38 PW88

**Two-valve : Blueprints, 1s. each.**  
Midget Short-wave Two (D, Pen) .. PW38A  
The "Fleet" Short-wave Two (D (HF Pen), Pen) .. 27.8.38 PW91

**Three-valve : Blueprints, 1s. each.**  
Experimenter's Short-wave Three (SG, D, Pow) .. 30.7.38 PW30A  
The Perfect 3 (D, 2 LF (RC and Trans)) .. 7.8.37 PW63

**The Band-Spread S.W. Three (HF Pen, D (Pen), Pen)** .. 1.10.38 PW68

**PORTABLES.**

**Three-valve : Blueprints, 1s. each.**  
F. J. Camm's 3LF Three-valve Portable (HF Pen, D, Pen) .. PW65  
Parvo Flyweight Midget Portable (SG, D, Pen) .. 3.6.39 PW77

**Four-valve : Blueprint, 1s.**  
"Imp" Portable 4 (D, LF, LF (Pen)) .. 10.8.38 PW86

**MISCELLANEOUS.**

S.W. Converter-Adapter (1 valve) .. PW13A

**AMATEUR WIRELESS AND WIRELESS MAGAZINE CRYSTAL SETS.**

**Blueprints, 6d. each.**  
Four-station Crystal Set .. 23.7.38 AW427  
1934 Crystal Set .. AW444  
150-mile Crystal Set .. AW450

**STRAIGHT SETS. Battery Operated.**

**One-valve : Blueprint, 1s.**  
B.B.C. Special One-valver .. AW387

**Two-valve : Blueprints, 1s. each.**  
Melody Ranger Two (D, Trans) .. AW388  
Full-volume Two (SG Det, Pen) .. AW392  
Lucerne Minor (D, Pen) .. AW426  
A Modern Two-valver .. WM409

**Three-valve : Blueprints, 1s. each.**  
Class B Three (D, Trans, Class B) .. AW386  
Fan and Family Three (D, Trans, Class B) .. 25.11.38 AW410

**£5 5s. S.G.3 (SG, D, Trans)** .. 2.12.38 AW412  
Lucerne Ranger (SG, D, Trans) .. AW422  
**£5 5s. Three : De Luxe Version (SG, D, Trans)** .. 19.5.34 AW435

**Lucerne Straight Three (D, RC, Trans)** .. AW497  
Transportable Three (SG, D, Pen) .. WM271  
Simple-Tune Three (SG, D, Pen) .. June '33 WM327

**Economy-Pentode Three (SG, D, Pen)** .. Oct. '33 WM337  
"W.M." 1934 Standard Three (SG, D, Pen) .. WM351  
£3 3s. Three (SG, D, Trans) .. Mar. '34 WM354

**1935 £6 6s. Battery Three (SG, D, Pen)** .. WM371  
PTP Three (Pen, D, Pen) .. WM389  
Certainty Three (SG, D, Pen) .. WM393

**Minute Three (SG, D, Trans)** .. Oct. '35 WM396  
All-Wave Winning Three (SG, D, Pen) .. WM400

**Four-valve : Blueprints, 1s. 6d. each.**  
65s. Four (SG, D, RC, Trans) .. AW370  
2HF Four (2 SG, D, Pen) .. AW421  
Self-contained Four (SG, D, LF, Class B) .. Aug. '33 WM331

**Lucerne Straight Four (SG, D, LF, Trans)** .. WM350  
**£5 5s. Battery Four (HF, D, 2 LF)** .. Feb. '35 WM351  
The H.K. Four (SG, SG, D, Pen) .. Mar. '35 WM384

**The Auto Straight Four (HF Pen, HF Pen, DDT, Pen)** .. Apr. '36 WM404

**Five-valve : Blueprints, 1s. 6d. each.**  
Super-quality Five (2 HF, D, RC, Trans) .. WM320  
Class B Quadradyné (2 SG, D, LF, Class B) .. WM314  
New Class B Five (2 SG, D, LF, Class B) .. WM340

**Mains Operated.**

**Two-valve : Blueprints, 1s. each.**  
Consoclectric Two (D, Pen) A.C. .. AW403  
Economy A.C. Two (D, Trans) A.C. .. WM285  
Unicorn A.C.-D.C. Two (D, Pen) .. WM394

**Three-valve : Blueprints, 1s. each.**  
Home Lover's New All-electric Three (SG, D, Trans) A.C. .. AW383  
Mantovani A.C. Three (HF Pen, D, Pen) .. WM874

**£15 15s. 1936 A.C. Radiogram (HF, D, Pen)** .. Jan. '36 WM101

**Four-valve : Blueprints, 1s. 6d. each.**  
All Metal Four (2 SG, D, Pen) .. July '33 WM329  
Harris' Jubilee Radiogram (HF Pen, D, LF, P) .. May '35 WM386

**SUPERHETS.**

**Battery Sets : Blueprints, 1s. 6d. each.**  
Modern Super Senior .. WM375  
Varsity Four .. Oct. '35 WM395  
The Request All-Waver .. June '36 WM407  
1935 Super-Five Battery (Superhet) .. WM379

**Mains Sets : Blueprints, 1s. 6d. each.**  
Reptode Super Three A.C. .. May '34 WM359  
"W.M." Radiogram Super A.C. .. WM369

**PORTABLES.**

**Four-valve : Blueprints, 1s. 6d. each.**  
Holiday Portable (SG, D, LF, Class B) .. AW393  
Family Portable (HF, D, RC, Trans) .. AW447

**Two H.F. Portable (2 SG, D, QP21)** .. WM363  
Tyers Portable (SG, D, 2 Trans) .. WM367

**SHORT-WAVE SETS—Battery Operated.**

**One-valve : Blueprints, 1s. each.**  
S.W. One-valver for America .. 15.10.38 AW429  
Rome Short-waver .. AW452

**Two-valve : Blueprints, 1s. each.**  
Ultra-short Battery Two (SG det, Pen) .. Feb. '36 WM402  
Home-made Coil Two (D, Pen) .. AW440

**Three-valve : Blueprints, 1s. each.**  
World-ranger Short-wave 3 (D, RC, Trans) .. AW355  
Experimenter's 5-metre Set (D, Trans, Super-regen) .. 30.6.34 AW438

**The Carrier Short-waver (SG, D, P)** .. July '35 WM390

**Four-valve : Blueprints, 1s. 6d. each.**  
A.W. Short-wave World-Beater (HF Pen, D, RC, Trans) .. AW436  
Empire Short-waver (SG, D, RC, Trans) .. WM313

**Standard Four-valver Short-waver (SG, D, LF, P)** .. WM333  
**Superhet : Blueprint, 1s. 6d.**  
Simplified Short-wave Super .. Nov. '35 WM397

**Mains Operated.**

**Two-valve : Blueprints, 1s. each.**  
Two-valve Mains Short-waver (D, Pen) A.C. .. AW458  
"W.M." Long-wave Converter .. WM380

**Three-valve : Blueprint, 1s.**  
Emigrator (SG, D, Pen) A.C. .. WM352

**Four-valve : Blueprint, 1s. 6d.**  
Standard Four-valve A.C. Short-waver (SG, D, RC, Trans) .. Aug. '35 WM391

**MISCELLANEOUS.**

S.W. One-valve Converter (Price 6d.) .. AW329  
Enthusiast's Power Amplifier (1/6) .. WM387  
Listener's 5-watt A.C. Amplifier (1/6) .. WM392

**Radio Unit (2v.) for WM392 (1/-)** .. Nov. '35 WM393  
Harris Electrogram battery amplifier (1/-) .. WM390  
De Luxe Concert A.C. Electrogram (1/-) .. Mar. '36 WM403

**New Style Short-wave Adapter (1/-)** .. WM388  
Trickle Charger (6d.) .. Jan. 5, '35 AW402

**Short-wave Adapter (1/-)** .. AW456  
**Superhet Converter (1/-)** .. AW457  
B.L.D.L.C. Short-wave Converter (1/-) .. May '36 WM405

**Wilson Tone Master (1/-)** .. June '36 WM100  
**The W.M. A.C. Short-wave Converter (1/-)** .. WM403