

THE T. & R.

BULLETIN

THE INC.
RADIO SOCIETY
OF GT. BRITAINAND THE
BRITISH EMPIRE
RADIO UNION

Vol. 8 No. 9

MARCH, 1933 (Copyright)

Price 1/6

FOREMOST
AS PIONEERS

The designer of the All-Mains Short-Wave Superhet Receiver, described in this issue, specifies these Varley components:—

		Price each
4	Varley 'Tag' Resistances 600 ohms	1/-
4	" " " 20,000 "	1/6
2	" " " 50,000 "	2/-
1	" " Resistance 100,000 "	2/-
1	" 3-Watt " 300 "	5/-
	(with universal holder)	
2	Varley Power Potentiometers. Wire-wound, giving noiseless and certain voltage control.	30,000 " 7/3
1	Pentode Output Transformer	DP 5 17/6
	Ratios 1.5:1 and 33:1. Max. primary current 40 m/a.	

(For low resistance speakers use Varley DP 32, price 21/-, giving choice of 7 ratios between 20:1 and 53:1.)

—all made by Varley, pioneers and leaders in radio component design since the earliest days of broadcasting.

FREE—Varley's latest illustrated brochure on Q.P.P. "The Battery Set Comes into its Own." Write for your copy to-day.



Varley

(Proprietors: Oliver Pell Control. Ltd)

BIG PRICE REDUCTIONS

in T.C.C. CONDENSERS

**OPERATIVE from
MARCH 1st.**

HERE are the NEW Prices of T.C.C. Condensers. No longer is there an excuse to buy condensers of inferior quality—of doubtful characteristics. Every T.C.C. Condenser has behind it the experience of over a quarter of a century's specialised work. True to specification—unquestioned dependability are factors that have made T.C.C. the premier amongst condensers. And now you can get them cheaper.

T.C.C.

ALL-BRITISH
CONDENSERS

PAPER CONDENSERS. TERMINAL TYPES

Mfd.	Type 50/61.	Type 80/81.	Type 101.	Type 121.
	s. d.	s. d.	s. d.	s. d.
0.1	—	2 0	—	—
0.25	—	2 4	—	—
0.5	2 4	2 6	5 0	7 0
1	2 6	3 0	6 0	8 6
2	3 6	4 0	9 0	13 0
3	5 0	6 0	—	—
4	5 6	7 0	17 6	25 0
5	7 3	9 0	22 0	31 0
6	8 6	10 6	25 0	37 6
8	11 0	14 0	—	—
10	14 0	17 6	—	—

PAPER CONDENSERS. SOLDERING TAG TYPES

Mfd.	Type 65.	Type 84.	Type 87.
	s. d.	s. d.	s. d.
0.1	1 8	2 0	2 2
0.25	1 10	2 2	2 4
0.5	1 11	2 4	2 6
1	2 0	2 9	3 0
2	2 8	3 9	4 0
3	—	—	—
4	5 0	6 9	7 3
5	—	—	—
6	7 0	10 0	—
8	9 0	13 0	—
10	11 6	16 0	—

Other types and capacities not mentioned above remain unaltered in price.

MICA CONDENSERS

Mfd.	Type M.	S.P. Type.	Type 34.
	s. d.	s. d.	s. d.
.00005	0 8	—	1 3
.0001/3	0 8	2 0	1 3
.0004/5	0 9	2 0	1 3
.001/4	1 0	2 6	1 6
.005/6	1 6	3 0	2 0
.01	2 0	—	3 0

ELECTROLYTIC CONDENSERS

Mfd.	Type 802 Aqueous.	Type 801 Aqueous.	Type 902 Dry.
	s. d.	s. d.	s. d.
8	6 0	—	6 6
4	5 0	—	—
7	—	6 0	—

THE TELEGRAPH CONDENSER CO., LTD., WALES FARM RD., N. ACTON, W.3



21 YEARS full & constant high-tension

Twenty-one years of steady high-tension from one unit, *without renewal or replacement*, is the amazing record of **THE WESTINGHOUSE METAL RECTIFIER.**

Users of Westinghouse METAL rectifiers state that their units have given 2, 3, 4 and 5 years continuous service without breakdown. But . . . our own official non-stop life test figures go further. They PROVE that, even after 46,500 hours continuous use on full load, no falling off in output sets in. This duration is equivalent to 21 YEARS OF LIFE WHEN USED 6 HOURS PER DAY; and no other method of rectification can show the smallest approach to such a standard of performance and efficiency.



METAL RECTIFIERS

are suitable for mains operation of transmitters. Send for full particulars **TO-DAY!**

The Westinghouse Brake & Saxby Signal Co., Ltd., 82, York Road, King's Cross, London, N.1.



... The Terminal Selected for the SHORT WAVE SUPER-HET

Extremely robust and soundly made. Hexagonal shoulder, which, by being held with a spanner while the nut behind is made tight, greatly facilitates mounting.

Insulated and non-removable head. Provision for secure, solderless connection. Clear and easily read markings.

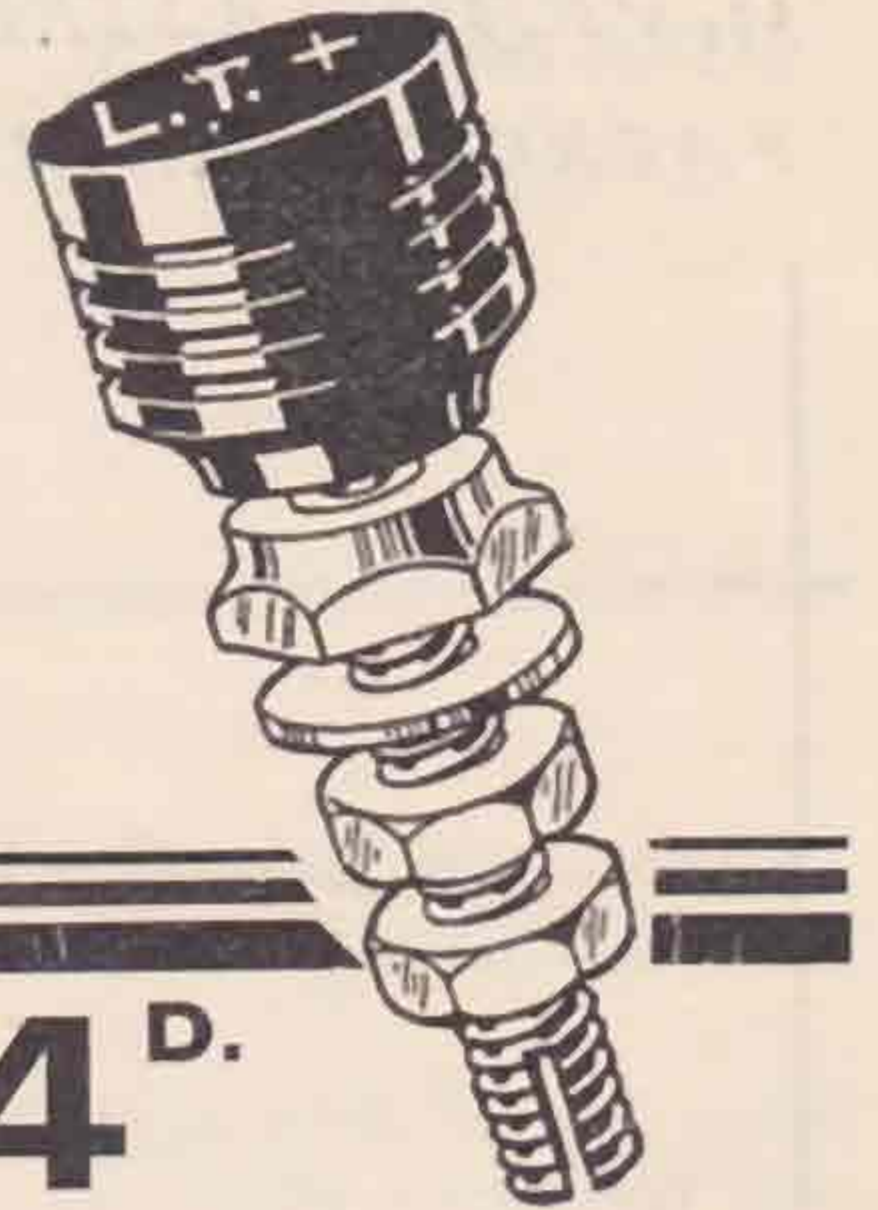

**CLIX PANEL
TERMINAL**
(Type B)

4^{D.}

CLIX
Chassis Mounting **VALVEHOLDER**

Although of the skeleton type, is sturdily built and suitable for metal, wood or ebonite mounting. Turned Resilient Sockets guarantee full surface contact without fear of collapse. Solid or resilient valve pins are taken with equal efficiency, and no arcing is possible when mains are used. Sockets move laterally to align with valve pins. Screw terminals for connections.

4 Pin Model 8d.	5 Pin Model 9d.
------------------------	------------------------

Write for the Clix Folder T/M.



LECTRO LINX LTD. 79a, ROCHESTER ROW, S.W.1.

THE INCORPORATED
RADIO SOCIETY OF GREAT BRITAIN

AND THE

BRITISH EMPIRE RADIO UNION

53, VICTORIA STREET, LONDON, S.W.1. (PHONE: VICTORIA 4412)

PATRON: H.R.H. THE PRINCE OF WALES, K.G.

R.S.G.B. CALENDAR.

Unless otherwise announced, all meetings are held at the Institution of Electrical Engineers, Savoy Place, W.C.2, commencing at 6.15 p.m. Tea is served at 5.30 p.m.

March 19. District 3 Conventionette at Birmingham.

March 31. Film Lecture by Bakelite Ltd. "The Story of Bakeloid Resinoid" (at the I.E.E.)

April 5. London Districts Dinner at Pinoli's Restaurant.

April 9. District 1 Conventionette at Liverpool.

April 26. "Recording Sound on Film," by Mr. J. Paddon, A.R.I.E. (at the I.E.E.)

OFFICERS FOR THE YEAR 1933

President: H. BEVAN SWIFT (G2TI)

Acting Vice-President - - - - - A. E. Watts (G6UN)

Honorary Secretary and Treasurer - - - E. Dawson Ostermeyer (G5AR)

COUNCIL

A. W. Alliston (G5LA), J. D. Chisholm, (G2CX), J. J. Curnow (G6CW), E. A. Dedman (G2NH), A. D. Gay (G6NF), J. W. Mathews (G6LL), H. B. Old (G2VQ), H. C. Page (G6PA), T. A. St. Johnston (G6UT), J. C. Watts (BRS246), H. V. Wilkins (G6WN).

Secretary: J. CLARRICOATS (G6CL).

All correspondence should be addressed to The Secretary (or other officer concerned), The Radio Society of Great Britain, 53, Victoria Street, London, S.W.1. Insufficiently addressed letters may be considerably delayed.

THE T. & R. BULLETIN

CONTENTS.

	Page
Test B.E.R.U.	273
All Mains Short-Wave Superhet- erodyne Receiver	274
Measurement of Radio Frequency ..	278
Directional Signals	281
Station Description—G6NF	282
Valves in Parallel	283
A Universal Aerial	284
Hic et Ubique	286
R.A.F. Flight and Mount Everest Expedition	290
Calibration Section	291
Apparatus Reviewed	291
A Novel Power Amplifier System ..	292
Grid Modulation	293
The Month on the Air	294
Contact Bureau Notes	296
Notes and News from the British Isles	298
Empire Notes and News	304

Hon. Editor:—

G. W. Thomas (G5YK)

Advertising Manager:—

H. Freeman

Vol. 8 No. 9

Editorial Committee:—

A. W. Alliston (G5LA).

J. D. Chisholm (G2CX).

J. J. Curnow (G6CW).

J. W. Mathews (G6LL)

A. O. Milne (G2MI).

TEST B.E.R.U.

TEST B.E.R.U.! Little did we think in 1931, when our first Empire Contest was staged, that in the short space of two years this event would become the most important annual milestone in Empire Amateur circles.

We visualised that a handful of enthusiastic DX members would perhaps give up an hour or two of their sleep in order to "work" a new part of the Empire. We fully expected the high power British stations and a few well-known Australian and New Zealand stations to run up ten, maybe twenty or thirty points, but nobody, not even our optimistic Publicity Manager or Neville Shrimpton of ZL4AO—who moved the initial contest proposition at the 1930 Convention—could foresee that the Contest was to become such an integral part of our life as Empire Amateurs.

It is early yet to comment, even briefly, on the Contest, except in a general way, but we feel that no time should be allowed to pass before a word of appreciation is given to those who have contributed to the overwhelming success of the Contest. By their help, by their perseverance and by their example they have made a contribution to Amateur Radio, the effects of which will be far reaching. A body of Empire Amateurs united under the somewhat mystical title B.E.R.U. will, we believe, be a force to be reckoned with in the near future. It is our own obvious duty to stand firm in the support of our Home Society, but we should, when opportunity arises, make greater use of the B.E.R.U. as a means of promoting better understanding between Empire Amateurs.

From its inception the keynote of the B.E.R.U. has been the improvement of relationships between the executives of the many Empire organisations. That we have succeeded is evident from the whole-hearted co-operation given by every single Empire Society and Group. Let us, then, in the months before us, do our utmost to interest our colleagues in an event and an organisation which will provide the greatest opportunity in our history of fostering Empire friendships.

What of the future Contests? In the way that the 1932 Contest surpassed the 1931 Contest, so did this year's surpass last year's but in a higher degree. Greater interest was shown by all concerned. More stations were on the air and longer hours were spent on the key. When the results are published we await with interest the report of the statisticians showing in which year the B.E.R.U. Contest, following its present rate of progress, will prove of such absorbing interest that *all* Empire members will maintain their stations on the air for the duration of the Contest!

Having thus looked into the future, please rest assured that the results will appear in these pages at the earliest possible moment. In the meantime we prepare for the next Contest—on paper for ourselves, and, for yourselves, in your respective stations, so that it may be an even more outstanding success.

ALL
MAINS

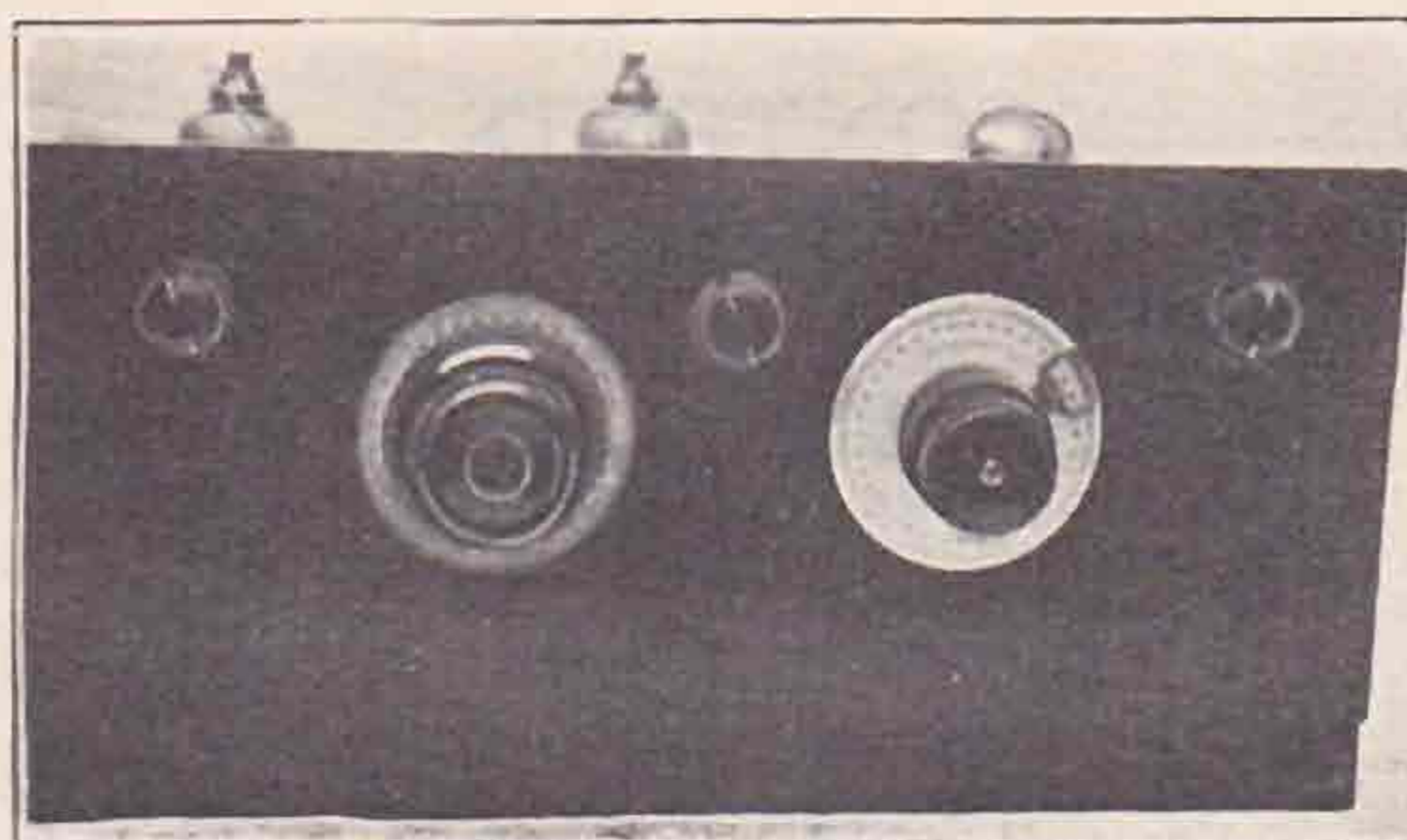

SHORT-
WAVE

SUPERHETERODYNE RECEIVER.

THE recent revival of interest in the superheterodyne method of reception has been prompted, no doubt, largely by the overcrowding upon the broadcast bands and the necessity for improvement in selectivity. Those who worked with superhets in the early days when frame aerials were used and the H.T. current was drawn from batteries, were only too glad to discard the principle when the screen-grid valve made its appearance. The expense of running a super in those days was no small matter, and three stages of intermediate frequency were considered essential to produce results which could justify the outlay.

With the improvements effected to-day, the super has risen to a very high degree of perfection; the charges of bad-toned output have been amply met, and the use of all-mains operation has overcome the cost of running.

It is this latter feature which has prompted the writer to devote his energies to this field during the past winter. He had already constructed two supers to operate upon the broadcast band, which produced results which offered no cause for complaints, so it was decided to see what could be done on the higher frequencies. Now we have had three or four supers already described in the BULLETIN, but only one was arranged for all-mains operation. In fact, the indirectly-heated valve seems to have been somewhat neglected for short-wave receiving sets. There appears to be an impression that these valves give a noisy background which prevents the clear reception of faint signals upon the higher frequencies, especially when used in a super. It will be admitted that the fact that an oscillating valve is used in the set will always produce a certain amount of hissing, but the ratio of signal output to this is so great that it is negligible. Furthermore, a loud-speaker can be used which provides far more comfortable reception than the constant wearing of headphones.

While it is comparatively simple to construct a super to operate upon the broadcast bands, the adaptation for operation upon the short waves is not so easy as it looks. The set described below has been altered quite a number of times before it was thought to be worthy of page space in the

BULLETIN. Other writers upon the subject have evidently had similar difficulties.

The writer started with the idea that the two main tuning controls could be ganged in order to provide a single tuning knob as in a broadcast receiver. This idea had to be scrapped at an early stage, for it appeared utterly impossible to get two short-wave circuits to tune in step together over even the limits of one of the amateur bands. Consequently separate condensers will be found in the set, and the writer believes this to be the only means of operation. Others may, however, have been more successful than the writer in this respect.

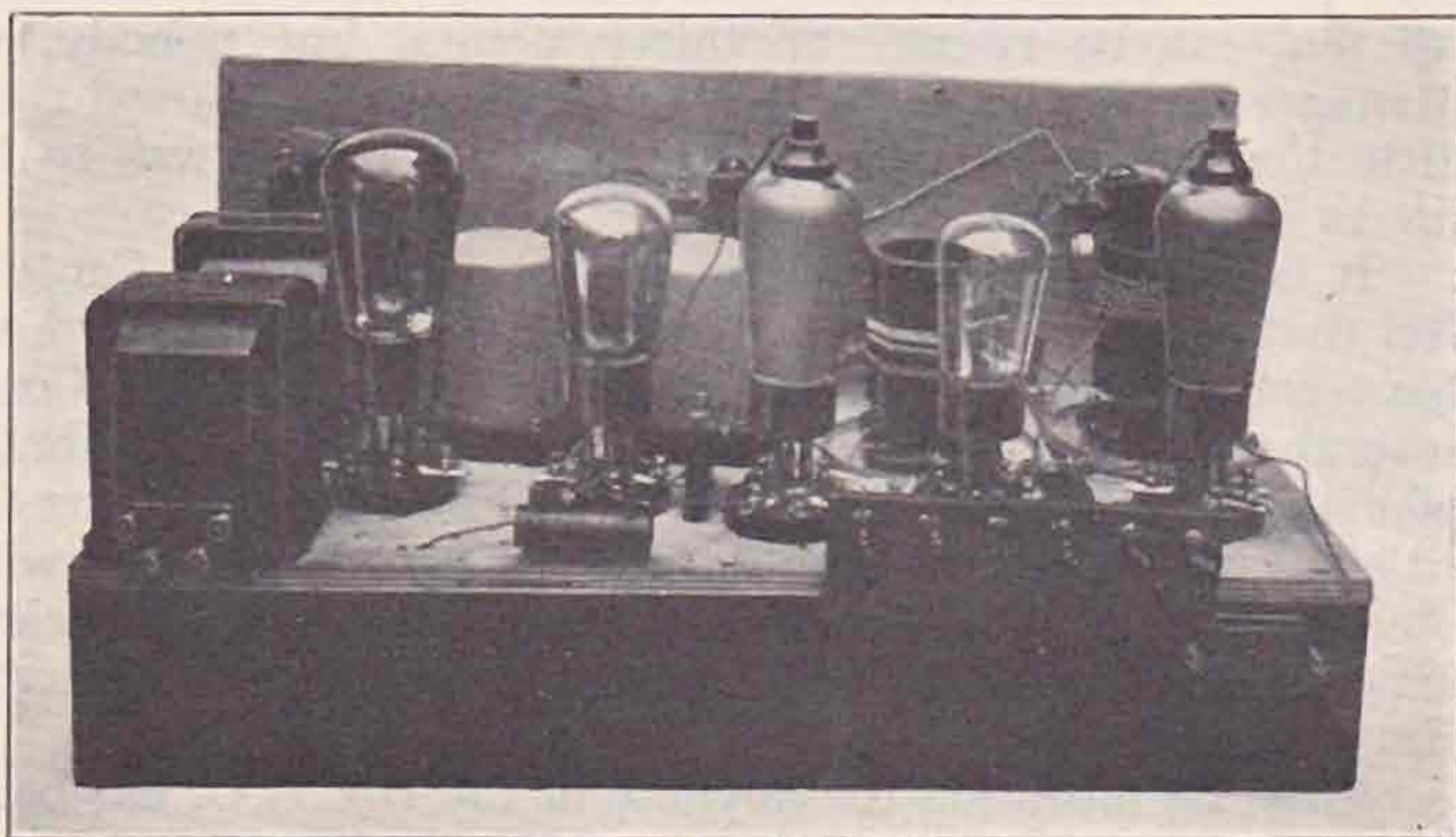

It is a great pity that it cannot be managed, for it still gives the double tuning upon the oscillator condenser, but this difficulty is easily overcome when the user gets into the habit of working both condensers together.

It had originally been intended also to use two stages of intermediate frequency. This, however, introduced a difficulty in preventing C.W. signals getting through to the second detector, and furthermore produced a certain amount of mush. With the single I.F. valve ample amplification is obtained, while the control is much simpler.

Another matter which does not affect the broadcast super is the fact that C.W. signals have to be received. Various proposals have been made for doing this. One way is to let the second detector oscillate by fitting reaction. Others provide a separate oscillating valve which can be cut in and

out of circuit as required. This certainly is the ideal method, but it introduces complications which hardly justify the added complication. The use of the Variable MU valves in the present set, which can be made to oscillate by raising the screen voltage, was finally decided upon, and this has been found the simplest method to employ.

Fig. 1 shows the circuit used, which will be found to follow, in its principal features, ordinary super practice. The aerial is tapped in upon the plug-in coil L_1 , which is tuned by the variable condenser C_1 . A compression type of condenser C_2 is placed in the aerial circuit. The first valve V_1 is the detector, and here a Variable MU valve is used. The screen voltage is controlled by the 50,000-ohm potentiometer P_1 with the usual stabilising condenser C_3 connected to earth. The cathode of this valve is connected to the pick-up coil L_2 , which is wound upon the plug-in coil of the oscillator valve. This valve V_2 is a triode (Mullard 354), with its grid circuit tuned by the variable condenser

as this valve is used in an oscillating state for C.W. reception. The bias of this valve also serves the first detector by the use of the potentiometer P_3 used as an adjustable resistance in this case. There is also a fixed resistance R_9 of 600 ohms used as a safety device. The plate circuit is fed through the primary of the second Colverdyne, with the decoupling resistance R_4 and stabilising condenser C_{14} .

The second detector is a Mullard 354, with grid condenser C_{15} and leak R_{10} . This was also found to work better with further bias resistance in the cathode lead R_{11} . The plate is fed through the 100,000-ohm resistance R_5 and the H.F. choke HFC_2 . It must be remembered that operating at the low frequency of 110 kc. the latter must be somewhat larger than usual. The writer preferred, in this case, to make a special H.F. choke, though no doubt many of the better makes upon the market for broadcast use will be quite suitable.

The low-frequency end of the super follows conventional lines, having a Ferranti intervalve

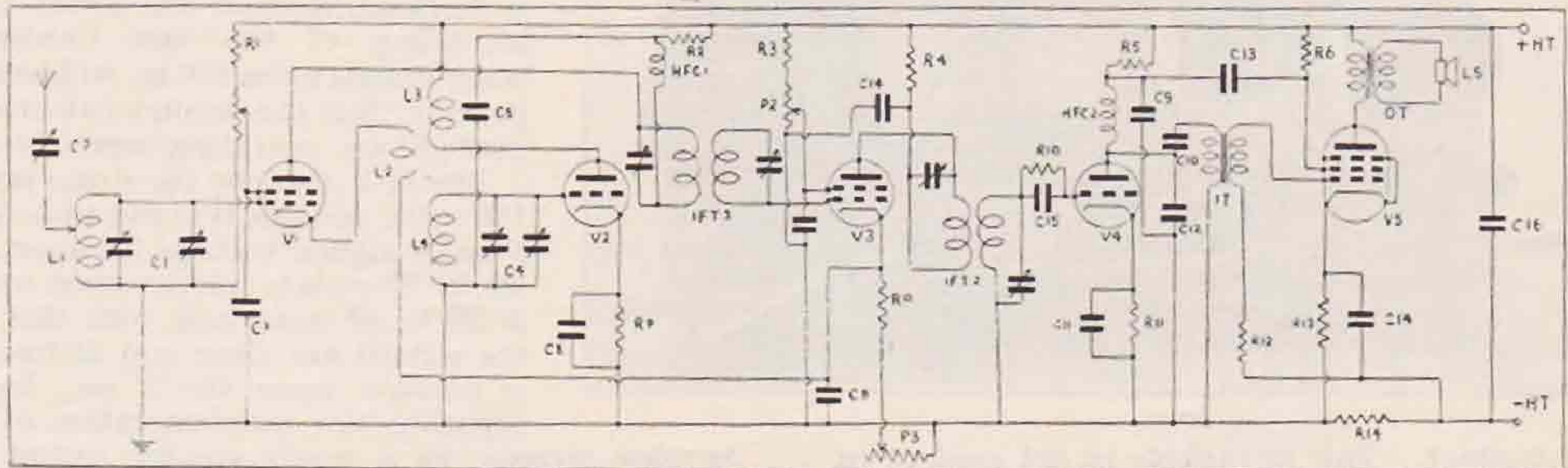

FIG. 1.

Condensers 1 and 4, .0001 mf. tank-Vernier. Polar Type A.

- .. 2, .0001 mf. max. Polar Preset.
- .. 3, 5, 6, 7, 9, 14. 0.1 mf. T.C.C.
- .. 8, 13. 1 mf. "
- .. 12, 15. 0.001 mf. "
- .. 10, 11. 2 mf. "
- .. 16. 6 mf. "

Resistances 1, 2, 3, 4. 20,000 ohms. Varley, tag type

- .. 5, 12. 50,000 "
- .. 6. 100,000 "
- .. 8. 1,000 "
- .. 9, 11, 12, 13. 600 "
- .. 14. 300 " Varley 3-watt
- .. 15. 0.25 megohm Dubilier

- P_1, P_2 , 30,000 ohms. Varley, power potentiometer.
- P_3 , 5,000 ohms, Varley power potentiometers.
- L_1, L_2, L_3, L_4 . Colvern formers, Type CF (see text).
- IT Ferranti AF6,
- OT Varley Pentode Output Transformer,
- $IFT_{1\&2}$ Colverdynes, 100 K.C.
- V_1 & V_3 Mullard, Variable Mu Valves, M/M.4V.
- V_2 & V_4 Mullard 354V.
- V_5 Mullard Pentode, PEN.4V,
- Clix Terminals, Panel Type.
- Eddystone Valve-holders.
- Colvern 6-pin Bases, with covers.

Note.—The screening grid control for V_1 should be marked P_1 in the diagram, and the secondary winding of IFT_1 should be connected to HT—. The condenser shunting R_8 should be marked C_6 .

C_4 . The latter for short-wave work is the most important of the two tuning controls, and the method of operation will be referred to later. This valve is biased by the 1,000-ohm resistance R_8 in the cathode lead, bridged by the by-pass condenser C_6 . The plate coil L_3 is fed direct from the H.T. + supply. The plate of the first detector V_1 is fed from the supply through a decoupling resistance R_2 , through the high-frequency choke HFC_1 , and the primary of the first intermediate frequency transformer IFT_1 . The latter is one of the well-known Colverdynes operating at 110 kc., and provided with self-contained trimming condensers. The secondary feeds the grid of the intermediate frequency valve V_3 . This is another variable MU, with its screen voltage controlled by the 50,000-ohm potentiometer P_2 , with additional resistance R_3 . This latter was found necessary in order to make the potentiometer control smoother,

transformer with its primary parallel fed from the detector plate through the condenser C_{10} . A 50,000-ohm decoupling resistance, R_{12} , is inserted in the secondary circuit. The output valve is a Mullard Pentode, type PEN.4V, with its auxiliary grid fed through the decoupling resistance R_6 . The biasing of this valve is dual, partly being performed by the cathode resistance R_{13} and partly by the resistance R_{14} in the negative lead. The plate is fed through the Varley pentode transformer, which is, in turn, connected to the loud-speaker.

The photographs show the general construction of the set. The base is a deep box in which all the fixed condensers and resistors are placed. The depth is sufficient to allow all the condensers to be mounted vertically. The anode choke for the second detector and the short-wave choke are also placed underneath. The other fittings are mounted

upon the upper side of the base, a thin copper foil sheet extends over the whole surface and up the back of the front panel. This provides all the screening necessary, and there is no evidence of hand capacity effects. The coils are provided in Colvern screening cases, while the two Variable MU valves are of the metallised type.

The valve holders are of the Eddystone type, which are particularly easy to fix and connect up, as the terminals can be manipulated with a screwdriver while the connecting legs can be bent into position to suit the solid pins of the valves, and can also be closed up if they open and fail to make

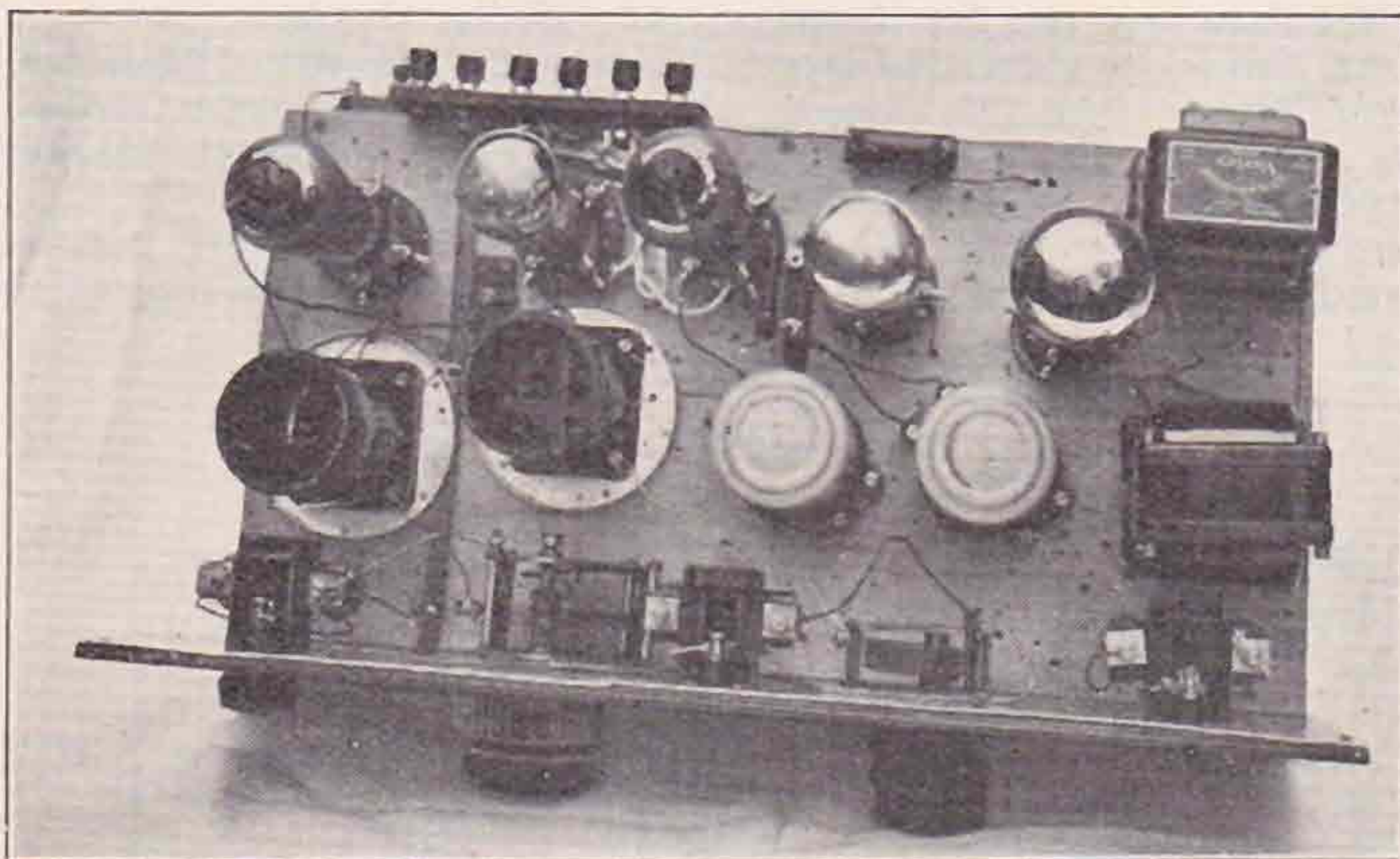

proper contact. This advantage is not evident in all valve-holders, and is of particular merit in short-wave work.

The coils are wound upon standard Colvern formers (type CF), with Colvern 6-pin bases. The coils shown in the table have been made so far.

Band	Aerial coil L_1 .		Oscillator coil.		
	Turns	Aerial tap from earth	L_2 (pick up)	L_4	L_3
3.5 mc.	15	6	7	17	17
7.0 mc.	7	$1\frac{1}{2}$	3	7	7
14 mc.	4	1	$2\frac{1}{2}$	4	4

For constructing the set it is very convenient to make up a pair of coils for the broadcast band, as these enable adjustments to be made very easily. In this case L_1 has 60 turns, with the aerial tapped in 10 turns from the earth end. The oscillator coil has 60 turns in the grid portion L_5 , 40 turns in the plate portion L_3 , and 10 turns in the pick-up portion. The wire used for winding all coils is No. 28 silk covered. Spacing between turns is only necessary upon the 14 mc. coils.

The three potentiometers are all mounted at the back of the front panel. That upon the left controls the screen voltage upon the first detector; the centre one is the adjustable resistance for the intermediate and first detector cathodes, while that upon the right controls the intermediate screen voltage to valve V_3 . When it is desired to receive C.W., the screen voltage is raised so that the valves just oscillate. It should be explained that Variable MU

valves were chosen because they appear to be singularly free from threshold howl.

There are many tips which soon become evident to those dealing with super work. The principal of these is the method of tracing trouble. The set can be considered as consisting of a number of separate portions, each of which can be tested separately to see if it is functioning properly. For instance, a milliamperemeter in the H.T. feed, to the oscillator, with all other valves removed, will drop in reading if the grid terminal is touched. This, of course, stops oscillation. Should there not be a drop it may mean that the plate coil is connected the wrong way round. Again the flex connection to the top (anode) terminal of the first detector may be removed and a pair of 'phones inserted. This then becomes a one-valve receiving set and signals should be heard.

To prove if the L.F. end of the set is working, connect the aerial to the secondary of the last Colverdyne, when signals upon 110 kc. will be heard, proving that the second detector and pentode are operating correctly.

The H.T. used by the writer is about 160 volts, and this is found to be better than a higher voltage for short-wave work. The plate current when working is 25 to 30 m.a., and with this value the signals are clear and distinct. It is possible upon the 7 mc. band to separate the conglomeration of over-

lapping signals to a much greater extent than with a straight set. Upon the 20-metre band the set produces splendid daytime work. So far not much success has been achieved upon 28 mc., but the writer is hoping to obtain better results with coil formers of smaller diameter.

In operating, the tank portions of the condensers are moved until the 110 kc. tuning is obtained.

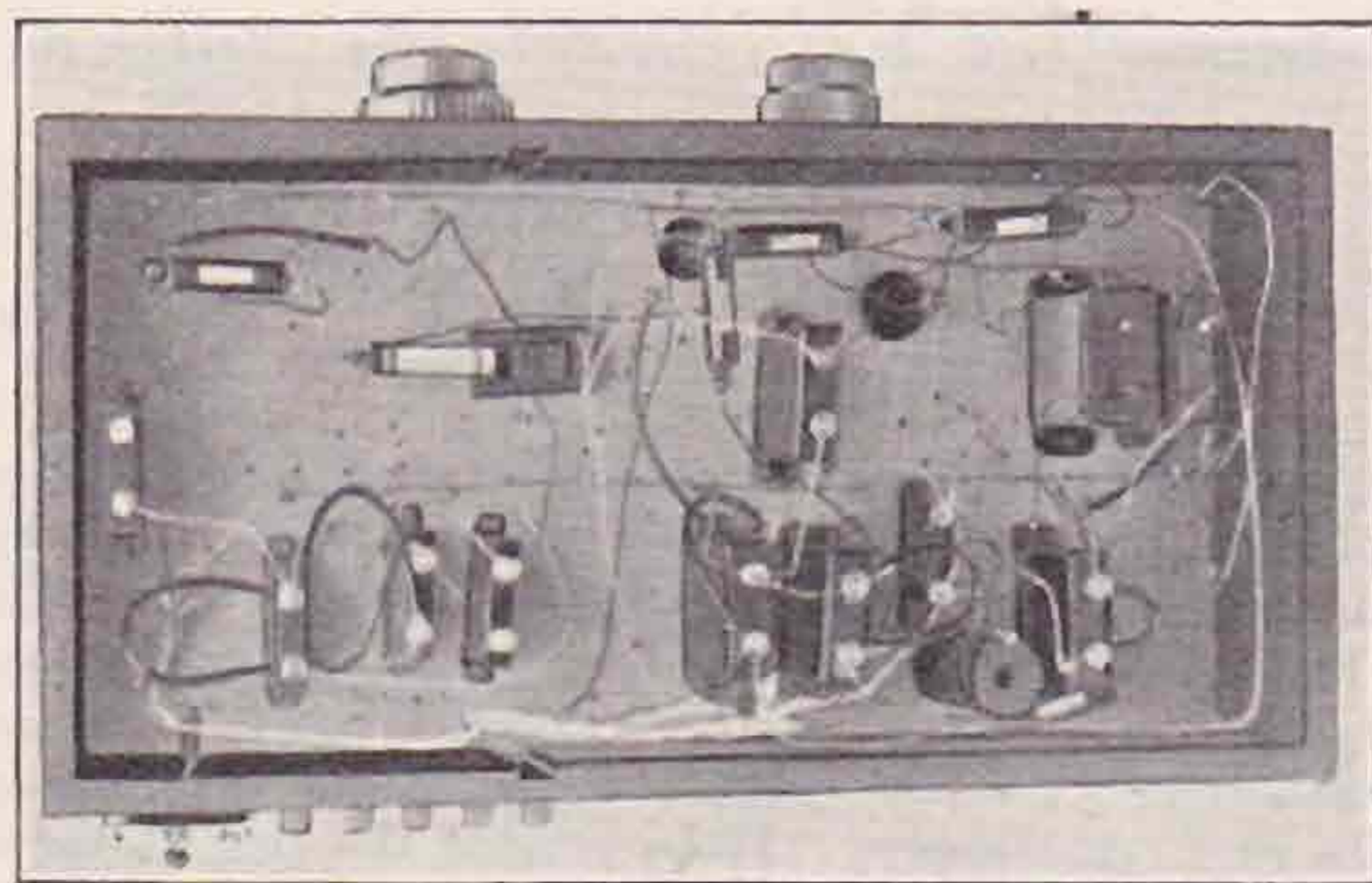

This will be noted by a rushing sound. Both condensers are then turned together until the band required is reached. The tank portions of the Polar (type A) condensers are at the back and provided with a separate dial. The verniers are in front and operated by the Utility dials. When the photos were taken these condensers had not yet been fitted, two small short-wave condensers being then used. There was only one Utility dial in use then upon the oscillator, it being thought that such fine adjustment was unnecessary for the aerial

tuning. However, it was found that fine adjustment was necessary, and the writer suggests that slow-motion dials be fitted to each portion.

Workers with ordinary sets may be puzzled at first with the working of the oscillator dial. When working upon the lower of the two positions, where signals are available, a reduction of capacity increases the wave-length. It is best, therefore, to work upon the upper position when the dials both turn in the same direction for wave-length increase.

There is also one point which affects super all-mains sets in ham use, that is switching off while transmitting. Owing to the length of time taken for the cathodes to heat up, it is impossible to switch them off while transmitting. There the H.T. alone must be switched, with the cathodes left on.

With this set the use of headphones is not advised. If a strong signal is struck suddenly the effect is painful. The writer has therefore adopted a plug-in

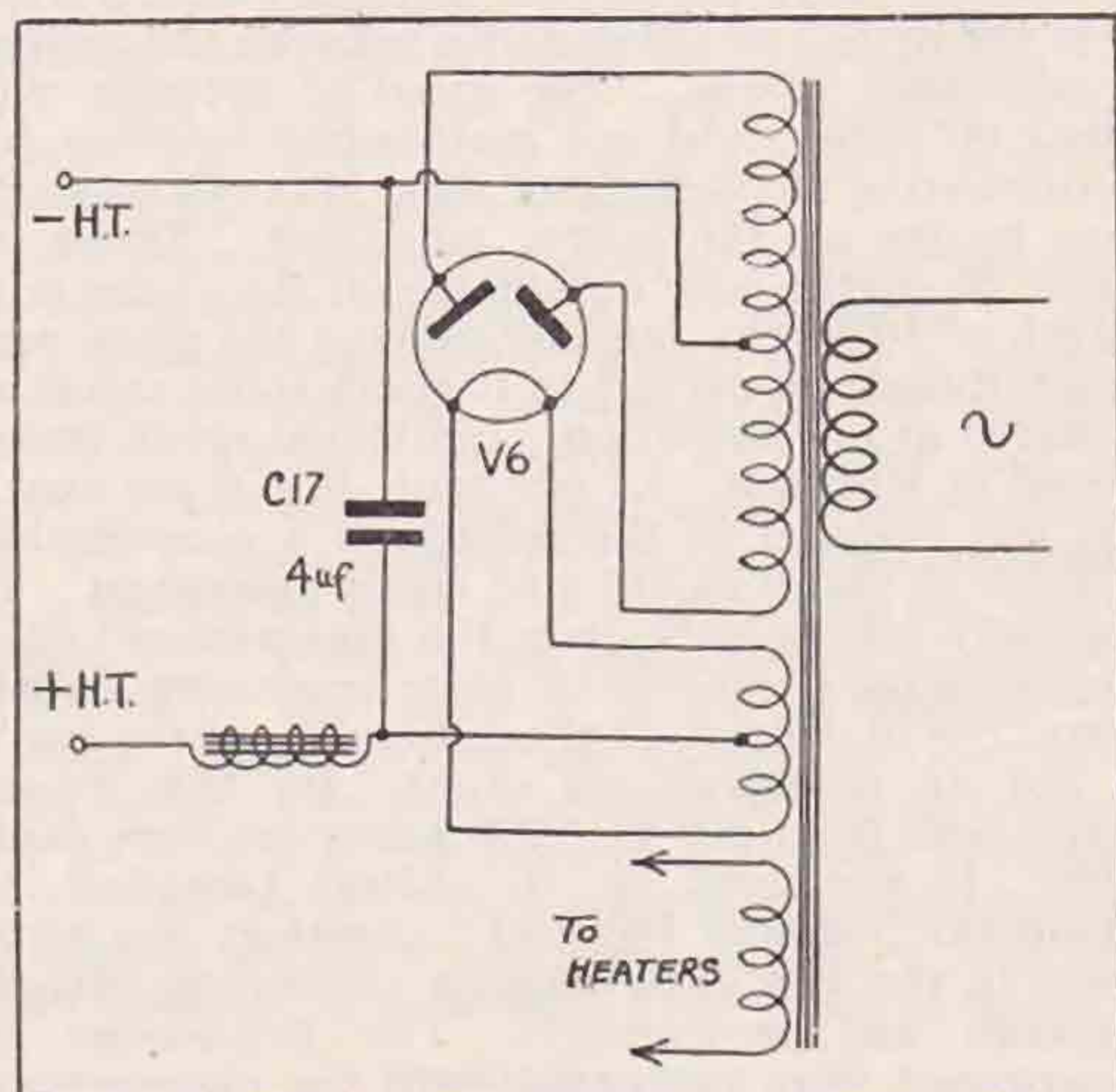

FIG. 2.

Mains Transformer, K-P secondaries
200-0-200 4V (1 amp), 4V (5 amp).
Choke, Ferranti, B.1.
C17—T.C.C., 4 mfd. 600 v. test.
V6 Mullard DW4.

arrangement for 'phones (not shown upon the drawing) in the second detector plate circuit, which is convenient when a weak signal is being taken.

A point which must be taken care of is to keep the flexible twisted together for the heating circuits to each valve. The Eddystone holders are particularly suited to this condition, as the base is a ring of moulded material. The flexible connection can be brought through a central hole and then separated out to each terminal. Each valve has a separate twin flexible cord brought back to the heater terminals. Glazite wire has been used for the remainder of the connections.

In the photographs, a lot of holes will be observed through the copper foil. These are the result of various alterations made as the set proceeded. It is intended to rebuild the set with new foil when time is available.

The resistances used are of Varley make with the exception of the low value cathode resistances and the negative bias resistance, which are home-

made and were not replaced in the set, as they acted effectively. It is suggested, however, that bought resistances can be used everywhere.

The mains unit is separate to the set, and follows conventional lines. The connections are shown in Fig. 2. The transformer in the set is made by K-P and proved very satisfactory. The rectifier valve is a Mullard DW4, which gives ample output. The smoothing consists of a Ferranti iron-cored choke, type B1, and two condensers, the latter of which is placed in the set. The heater connection should consist of heavy radiator pattern flex to prevent any drop in voltage, and it is advisable to earth one side of the heater circuit. It was found that this mains unit gave a perfectly smooth and silent output without a trace of mains hum anywhere.

THE 1932 LOW POWER CONTEST.

As in former years, the support given to this interesting little contest was much below expectations, but judging by the appreciation expressed by the fourteen members who took part, it seems that considerable enjoyment was obtained.

Once again Scotland has provided the winner, and we heartily congratulate Mr. Stove (G5ZX) upon having brought the third R.S.G.B. award to his country this year. It is interesting to note that the winner and several other entrants took full advantage of the modified rule which allowed contestants to use any input, providing the source of supply did not exceed 100 volts.

From Mr. Stove's entry it is learnt that, by using a push-pull circuit, he was able to obtain an input of between 3 and 4 watts.

The first seven stations in order of merit were:—

- Mr. Stove (G5ZX), Glasgow, 278 points.
- Mr. Scarr (G2WS), Leeds, 211 points.
- Mr. Cargill (G5LR), Salford, 185 points.
- Mr. Robb (GI6TK), Belfast, 176 points.
- Mr. Taylor (G5TL), Birmingham, 110 points.
- Mr. P. H. Dutton (G5IX), Skegness, 98 points.
- Mr. R. D. L. Dutton (G6QQ), Headington, Oxford, 98 points.

The following also entered and are recorded in order of merit: G5TU, 6TQ, 5LQ, 6CD, 6KI, GI5UR and 6XN.

Seven mc. was the most used frequency, although a fair number of contacts were made on the 1.7, 3.5 and 14 mc. bands. Mr. Stove made 43 contacts and used two S.P.55R. valves in push-pull, whilst a conventional Zepp aerial was employed throughout the tests. Two contacts with Budapest represented his DX. Mr. Scarr, the runner-up, effected 36 QSOs, and also used a push-pull transmitter with an input of 1.6 watts. His best contact was with CT3AB, a distance of 1,650 miles.

Mr. Cargill, who finished third, made 23 QSOs, with CT2AA (1,620 miles) as best DX. His average QRB per QSO was 745 miles. Here again a push-pull C.C. arrangement was favoured.

The Contest Committee in their report drew attention to the "scrappy" manner in which many of the logs were prepared, and ask all competitors, in future tests, to make their entries clear and legible.

In concluding this short summary of the contest, we wish to thank all members who co-operated.

MEASUREMENT OF RADIO FREQUENCY

A Paper read before the Society by E. H. RAYNER, Sc.D.

ON December 20, 1932, Dr. E. H. Rayner gave a very interesting lecture before the Society, entitled "International Co-operation in Radio Research." The greater part of the lecture is reproduced here in full.

There is, said Dr. Rayner, an International Research Council acting as a co-ordinating authority for a number of International Unions devoting their time to different problems. The Radio Union, which is of chief interest to us, has held meetings about every two years. Dr. R. B. Goldschmidt, of Brussels, acts as Secretary-General, and until his untimely death General Ferrie was their President.

The International Radio Union is supported by nations each with a National Committee, so that there is a very large amount of knowledge and experience available for the work of the Union. At present it divides its work among the following five committees:—

- (1) Standards—Chairman: the late Dr. Dye.
- (2) Propagation of Waves—Chairman: the late Dr. L. W. Austin.
- (3) Atmospherics—Chairman: Prof. E. V. Appleton.
- (4) Liaison—Chairman: Dr. A. E. Kennelly.
- (5) Theory—Chairman: Dr. Van der Pol.

The work of the Standards Committee has been largely concerned with the consideration and development of methods of generating frequencies of great steadiness and with methods of comparing the performance of standards of frequency, particularly from the international point of view. The late Dr. Dye did much to bring the art of what may be called "frequency" generation to its present very wonderful perfection.

Continuing, Dr. Rayner said that in the utilisation of radio propagation the range of frequency made use of is very large. Audio-frequency may be taken as roughly 10 to 10,000 cycles, a ratio of 1-1000, covering the whole musical scale, and including the subtle differences associated with variation of harmonic content by which we differentiate one person's voice from another's.

The art of radio transmission already utilises frequencies from 10,000 to 10,000 times 10,000 = 10^8 (=3 metre wave-length). Another power of 10 is well in sight, making a ratio of 100,000 in the case of waves of the order of 30 cm. The range is one hundred fold that of the ear.

In the measurement of frequency we have then the problem of determining the value of a very short interval of time to a very high accuracy. Let us look at the problem as it stood before the thermionic valve, with its manifold uses, was developed by groping experiment, supplemented by the wit and wisdom of man. The only method of generating high frequency was by charging a condenser electrically, until a voltage was reached which broke down the insulating property of air. After this has happened the resistance of the path is reduced to a low value; and, with a suitable inductance in the circuit, an oscillatory discharge

is obtainable, giving rise to two bright flashes in the arc path in every oscillation. A fair number of these sparks can be obtained for each charging up of the condenser. The luminous effect of these sparks was, 25 years ago, one of the few phenomena which could be utilised to measure their frequency. The method adopted at the National Physical Laboratory was to photograph the sparks after reflection in a concave mirror 2 metres from the plate. The mirror 4 cm. diameter was rotated about a vertical axis at a high speed, in order to separate the images of successive sparks. The time between successive sparks, 2 per cycle, was determined from the speed of rotation of the mirror, the distance of the mirror from the plate and the distance between the images of successive sparks. The speed of rotation was about 60 cycles, and was maintained constant by incorporating a commutator for a Maxwell capacitance bridge on the mirror mounting. Trains of about 20 sparks were obtainable on the plates in a length of 10-15 cm., and by moving the plate vertically during exposure 5 to 10 spark trains could be recorded at one operation. Individual spark trains varied in length by 0.2 per cent. to 0.6 per cent., but the averages of the records of a considerable number of plates would give closer agreement. It naturally all depends upon the measurement of a length on the photographic plate separating images somewhat ill defined, as the luminosity of the spark is not an instantaneous event. By this means frequencies from 300 to 1,200 kilocycles were dealt with. It was done by Mr. Albert Campbell, to whom the National Physical Laboratory has owed much in the way of developing alternating current methods and instruments. The frequencies so determined were compared with the observations of a wavemeter loosely coupled to the circuit. The natural frequency of the wavemeter was calculated from the measured values of L and C. The results agreed very closely.

The difficulties in computing frequencies to a high accuracy are that every inductance has distributed capacity, and capacity to its surroundings, and every part of the circuit has inductance, so it was necessary to find out by direct measurement how these might affect the oscillation frequency, as their effects vary with frequency and disposition of the circuits and are very difficult to allow for when high accuracy is required.

This work was done in the days of the spark and arc transmitters. The shortness of the wave trains in a spark transmitter made it useless to attempt any high accuracy of frequency maintenance. Arc generation could make more effective use of precision, if it had been necessary, but no accuracy comparable with modern requirements was dreamt of. The thermionic valve with its continuous operation has naturally entirely altered matters. Instead of being restricted to using only a few oscillations for the measurement of the period, we can use an indefinite number, provided we know what the number is and also know that the oscillation frequency is sufficiently constant.

In one set of apparatus at the National Physical Laboratory we can use about 12,000,000,000 oscillations, taking a week for their duration. If we can measure the week to 0.1 second, an accuracy attainable without difficulty, we know its value to 1 part in 6 million, or 1.3 in 10^7 . An accuracy of this order, 1 part in 10 million, is what is becoming necessary for standards for the world's commercial requirements.

The simplest form of radio frequency governor is a suitable arrangement of capacity and inductance. Electrostatic energy and electromagnetic induction are the stiffness and inertia of the vibrating system. Experience shows, however, that schemes of this sort have not as yet the operational stability necessary for the highest accuracy. Much fundamental work has been done and much more will be done on these lines; but the subject in its essence is of great analytic difficulty, complicated by the operational characteristics of valves, etc., whose distributed reactances, varying with voltage and filament temperature, enter into the problem. It has been found that the flywheel effect of the inertia and stiffness of solid matter provides a better type of oscillation governor.

We are not particular as to what that frequency is within quite wide limits. It might be as slow as a seconds pendulum (it should really be called a 2 seconds pendulum), or it might be 100,000 times as fast. Physical properties of matter and experience will lead to the most suitable contrivances. At the present moment a fundamental frequency of 1,000 cycles is in very considerable use, but it seems quite possible that for the best results frequencies of the order of 10,000 to 100,000 will become common. We are talking of the use of solid bodies as frequency governors, and an interesting point is that the mass of governors developed by various people, which have been found effective as regards precision and constancy, vary from less than 0.5 gram to more than 1,000 times as much.

Multivibrator.

A great advance in the art of measurement of radio frequencies was made as a result of the work of Abraham and Bloch in developing their multivibrator. The object of this equipment was to produce very rapid electrical impulses at regular intervals of time, the pulses being short compared with the length of interval. Such a scheme can be made to give electrical "kicks" to an oscillatory circuit having a frequency n times the period of the kicks where n is a whole number. The oscillatory circuit receives a kick every n th oscillation, which is sufficient to keep it going. In practice n may be from 1 to 100 or more, and a small amount of detuning does not affect the frequency which is forced to keep to n times the fundamental, even if just before a kick it is slightly out of step. Putting it further out of time will cause the circuit to respond to the $(n+1)$ or $(n-1)$ th harmonic. The process of picking out a high multiple can be repeated, the n th harmonic of the basic frequency caused to give the "kick" characteristic, and so to form the basis of another series of a much higher frequency. Comparisons of a known with an unknown frequency are made by observations of beat frequency.

In the original multivibrator the frequency, for which 1,000 cycles is commonly used, has no definite stability of an inertia kind, electric or

mechanical. It is produced by a relaxation type of oscillation, and a high degree of constancy is hardly attainable with oscillations of this kind. The scheme was made into one capable of very high precision by governing the fundamental "kick" frequency by an electrically maintained tuning fork. This development was due to the late Dr. Dye, and equipment of this type forms the basic apparatus for the determination of frequency in more than 50 laboratories, some in this country, some in the Dominions, and others in several countries of the world.

The other oscillator of the mechanical inertia type in common use is crystalline quartz. Some account of the very wonderful and complicated types of vibration to which it gives rise has been given to the Society at a previous meeting. Both types of oscillator are valve driven. Regulation of temperature and pressure are of first importance. Quartz is often operated in vacuo.

Tuning Fork Oscillators.

At the National Physical Laboratory the fundamental tuning fork oscillator has a frequency of 1,000 cycles. It is of a form developed by the late Dr. Dye. A fork of 1,000 cycles is very stiff compared with the more usual 512; and the amplitude is very small for a large amount of stored energy, a property which facilitates satisfactory operation. The tuning fork is kept in a vault in the centre of the basement of Bushy House at Teddington, which has very thick walls and a temperature variation of about 2°C . during the year. The fork is in an airtight box which is kept at constant temperature. From it circuits are available for transmitting the 1,000 cycles to different parts of the Laboratory or for connection to the public telephone system. The fork operates a phonic motor and gearing, which finally rotates a chronograph drum at 1 revolution per "fork" second. A clock dial is also incorporated in the mechanism. On the drum time signals from a standard clock and other time-keeping apparatus are recorded electrically.

There is little doubt that a tuning fork of 1,000 cycles per second will keep steady to a few hundredths of a second a week. The limiting conditions appear to be the maintenance of steadiness of temperature and pressure, and of the driving conditions. These conditions include the steadiness of characteristics of the valve driving the apparatus—a point of serious importance—and of the anode voltage and filament temperature.

Quartz Oscillator.

Though the tuning fork can equal the best types of clock, it seems probable that the piezo electric properties of quartz, combined with its other physical properties, will enable it to be used as the most perfect time-dividing machine at present in sight. You all know that when crystals of quartz are electrified in certain directions, change of dimensions takes place, and as the cause and effect can be interchanged quartz may be used as a detector of a particular frequency or number of frequencies, and also as an oscillator for the provision of one or more frequencies.

Again I should like to draw your attention for a minute to the size of the quantities made use of. We talk of vibrating plates and bars of quartz, but what is the amount of the alteration in size in-

volved? I confess that in looking into the subject the result was rather surprising. If we take a piece of quartz 1 cm. thick cut in one of the usual directions (Curie cut) from a crystal and electrify it across the thickness with 300 volts, it will alter in length about 6.3 parts in 100 million, an amount difficult to realise. If the bar were 1 kilometre long, the change in length would be $6.3/1000$ of a centimetre, $2\frac{1}{2}/1000$ of an inch. The effect is proportional to the potential gradient and I have taken unit ES potential gradient $1\text{ESU}/\text{cm.} = \frac{300\text{ Volts.}}{\text{Cm.}}$ In practice one might use a slip 0.1 cm.

thick and possibly put the voltage up to, say, 3,000. This would make the combined effect of voltage gradient and alteration in length 100 fold as great, so that the rod of 1 kilometre would alter $6.3/10$ of a centimetre, $2.5/10$ of an inch.

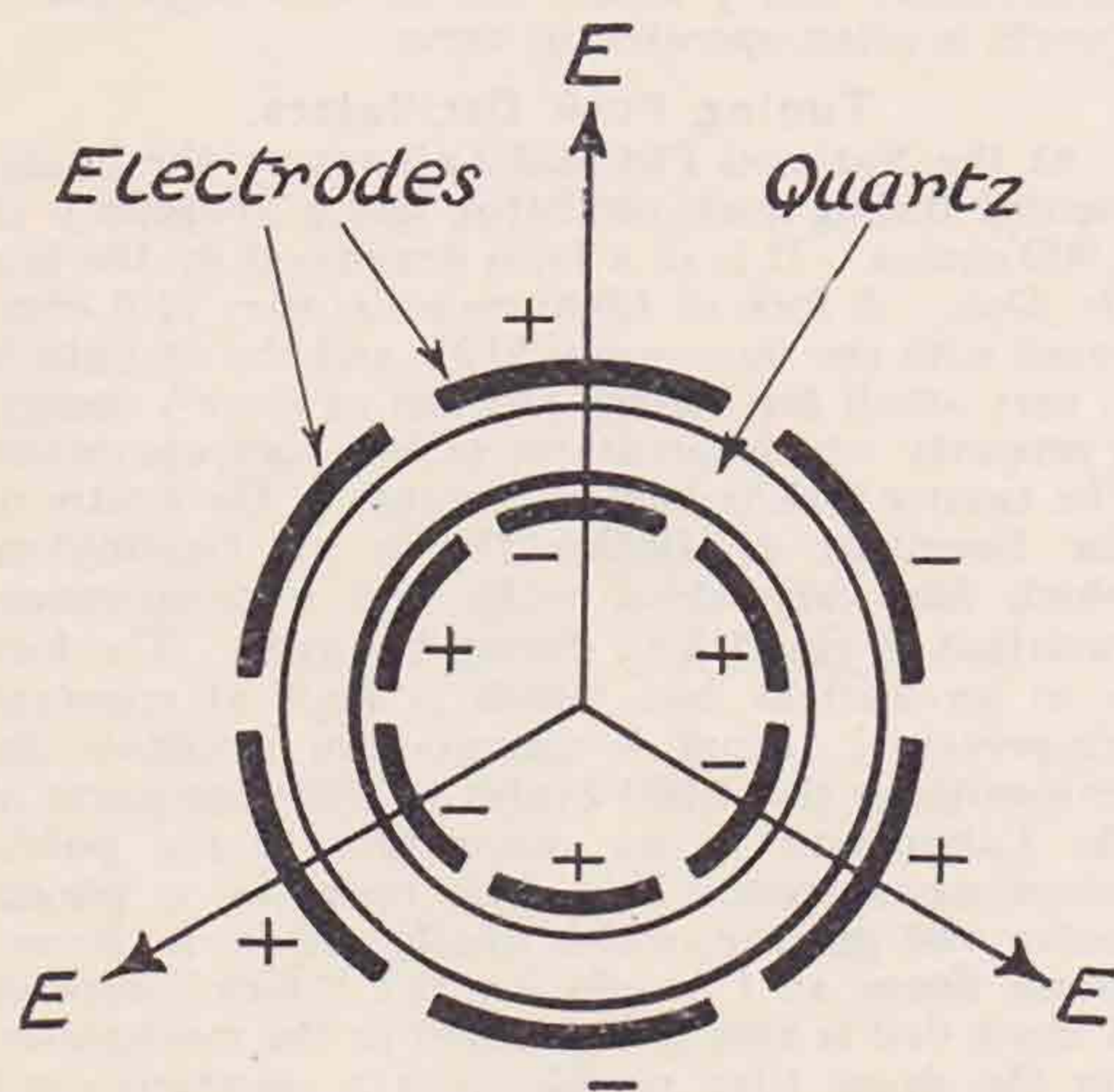

Here we see the late Dr. Dye's method of mounting a quartz ring between six pairs of electrodes.

It is this type of alteration, causing changes of form reckoned in millionths or fractions of a millionth of its dimensions—which is so perfect in constancy and absorbs so little power—that has provided new possibilities for the measurements of time. These will have a wide application and open up roads to new knowledge of the greatest interest.

I propose to give a short description of three types of oscillator, which have been developed, suitable for radio frequency standards and used for clock driving, so that, as timekeepers, they are of an "absolute" nature and can be compared directly with astronomical observations, if desired. They do not need a frequency of a similar value for their calibration.

The Ring Oscillator of Dr. Dye.

A consideration of the physical properties of quartz led the late Dr. Dye to devise a ring form of oscillator with the axis of the ring parallel to the optic axis of the crystal. This is to be distinguished from the Marrison ring form with the axis in a different direction.

When a radial electric field, produced by a metallic cylinder outside and another inside the ring, acts on the quartz, part of the circumference stretches and part shrinks an equal amount. Three sections stretch and three intermediate sections shrink. If the polarity is reversed the action is reversed. It therefore follows that if the cylinders are cut into six sections and alternately polarised, the ring will stretch or shrink as a whole, according to the polarity; and, by connecting it to the usual type of valve circuit, oscillations will start automatically and continue at the natural frequency of the quartz, depending on its mass and stiffness. This frequency works out at the value of the frequency of longitudinal oscillation of a rod, equal in length to half the mean circumference of the ring.

Crystals of quartz are limited in size, and a ring of about 100 mm. diameter is as large as is obtainable. Such a ring can be adjusted to give a frequency of 20,000 cycles per second. At this frequency the air in contact with the ring has an appreciable inertia and damping effect. The wavelength of the sound is about 15 mm., comparable with that

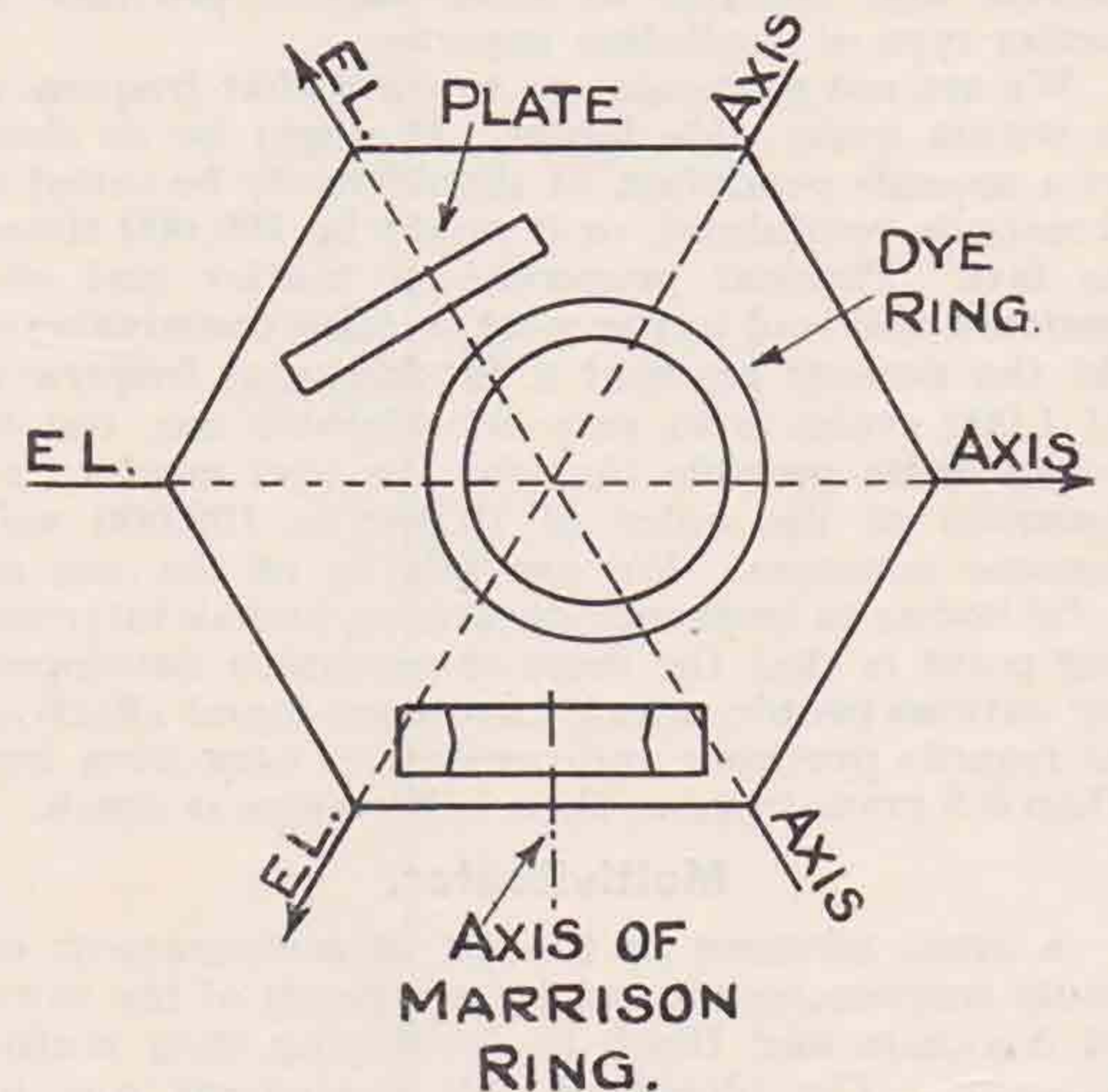

This diagram indicates the method of cutting the usual type of plates from quartz, and also the two types of ring oscillator.

which would cause resonance in the air between the ring and the exciting electrodes. There are, therefore, obvious advantages in putting the ring in vacuo. The ring is supported by three loops of fine metal strip, at points between the electrodes where the radial electric field is zero. The frequency is adjusted by removing some of the external or internal cylindrical surface, final adjustment being made by fixing the thermostat regulator by trial and error, the coefficient being of the order of 2×10^6 . The 20,000 cycles so generated is put through frequency dividing circuits giving 5,000 and 1,000 cycles in succession. The latter operates a phonic motor and gearing giving electric signals every second. These can be applied to the tuning fork chronograph.

There has not been sufficient time to prove the performance of ring oscillators over any extended period, but there is little doubt that a steadiness

superior to that of a fork is available. The temperature coefficient is less, and quartz is less susceptible to variation of driving conditions.

Marrison Crystal Clock.

One of the most complete time machines has been developed by Marrison, of the Bell Laboratories in America. A circular slab of quartz is used, of a thickness of about 28 mm., with the axis at 30° to an electrical axis of the crystal. The vibration of a thin rod of quartz is fairly simple, but when the length, breadth and thickness are of much the same order of dimension, it becomes most complicated. A large amount of work has been done by Lack on the subject, and from this and other information it appeared that making a hole through the slab might produce a very material improvement in its physical properties. The reason is that the normal mode of oscillation of a slab has a temperature coefficient of about 30 in 10^6 , and it was hoped that this would be diminished by varying the size and direction of axis, and it was found that when making a small disc out of a large one the ring left behind has a lower coefficient than the original disc and considerably smaller than that of the small disc cut out. The coefficient has been reduced to about 1 in 10^6 . The temperature coefficient of stiffness of quartz varies in different directions, and it also varies from positive to

negative. These can be balanced by cutting to a suitable shape, and the ring form is a shape of this type. The external diameter is about 86 mm., and the internal diameter about 39 mm. The internal surface is bi-conical, to afford a definite localised point of support.

As applied to time-keeping, four complete thermostated oscillators are used, running continuously. Their frequency is 100,000 cycles. Their steadiness is verified by making three beat against a fourth similar one. The beats are slow, the period being of the order of a minute or longer. Each of the three in turn is connected up to the fourth automatically for 1,000 seconds, and the beats between the two are added up mechanically on a counter. After 3,000 seconds, 50 minutes, the first one is again connected, and the beats in each period are type-printed on a piece of paper. If the fourth oscillator drifts slowly in frequency it does not matter, as the beats against the three will all alter together.

Frequency dividing circuits are used, giving 10,000 cycles and 1,000 cycles. The 1,000 cycles drives a synchronous motor which in turn drives small generators of 100 cycles and 10 cycles and clock hands. Constancy of the order of 0.01 second per day is obtained.

(To be concluded.)

DIRECTIONAL SIGNALS.

BY CAPT. A. M. HOUSTON FERGUS (G2ZC).

ON examining the chart of signal strengths in the 2 mc. R.S.G.B. Tests, Jersey appears amongst the places logged, and as I happened to be the only station entering for the tests I can only deduce that the reference refers to my station. This being so, the matter of directional aerials seems to need a little examination, and for this purpose the following facts might interest some members. I have several aerials, but in the 1932 2 m.c. tests, as well as for those of 1930, I used the same aerial, which is a Marconi type (with earth), 68 ft. long overall, and 30 ft. high, with the free end N by E, and this same aerial has also been in use on both 3.5 and 7 mc. as well.

By looking at the chart in the BULLETIN, if we join up Aberdeen, Leeds and Jersey, we get, roughly, a straight line.

Now in both the 1930 and 1932 2 mc. tests I found this aerial to have strong directional effects to the north, and west of north. The same aerial used on 3.5 mc. has a decided effect north and east of north, and on 7 mc., it does not appear to have any directional effects at all, while on 14 mc. the aerial is useless.

On 2, 3 and 7 mc. there is no doubt, but the aerial is efficient, as with small powers it appears to be efficient in the directions indicated, but why should it have such decided alteration of directional effects with a change of frequency?

To the nearest point of England we can say that we have 100 miles of sea, and there is not the slightest doubt that the sea does assist signals, from

reports received on small power, but we cannot blame the sea for an alteration of directional effects, and an explanation of this would be interesting.

The aerial used for reception is directional almost due west (free end). Without realising that G6FN was a Scottish station, I took him to be a south country one, as his signals were easily the most consistent throughout the 1932 tests from any British station, and once he became audible, G6IZ "roared in" also. Here we have cases of roughly north and south conditions, and it gives food for thought for those in favour of signals travelling more easily in a north and south direction, *i.e.*, in lines of magnetic force. Both G6ND and G6YL were received well, and from the fact that these northern stations were all almost equal to the extreme south coast stations (G5MU, G2DN, G5XR, etc.) surely the question of skip arises.

If anyone noticed it, G6YL'S theory (Group 2B) as regards the moon and atmospherics, was most evident during the tests, and if we also examine the theory of the 11 year cycle (as reported in the groups of C.B.) and compare this to what is being found on 56, 28 and 2 mc., and what was found in the 2 mc. tests, there appears to be still more facts in favour of such conditions being actual fact.

In these few lines I did not set out to do anything but to state certain facts, and yet there must be some reason for it all. Maybe, someone else has noticed similar happenings, and may be able to give an explanation?

STATION DESCRIPTION No. 30.

G6NF

By G5AW.

AMONG the South London stations active to-day, G6NF can be relied upon for an excellent transmission of both C.W. and telephony. This station, situated on rather high ground at West Norwood, was first licensed in August, 1923, although the owner's interest had

G6NF in the past six months or more he has been busy on frequency measurements.

The station itself is at the top of the house and occupies two rooms, the outer room is used mainly for constructional work, and as G6NF will always make an article, if possible, many hours are spent here. This room is also used for making tempera-

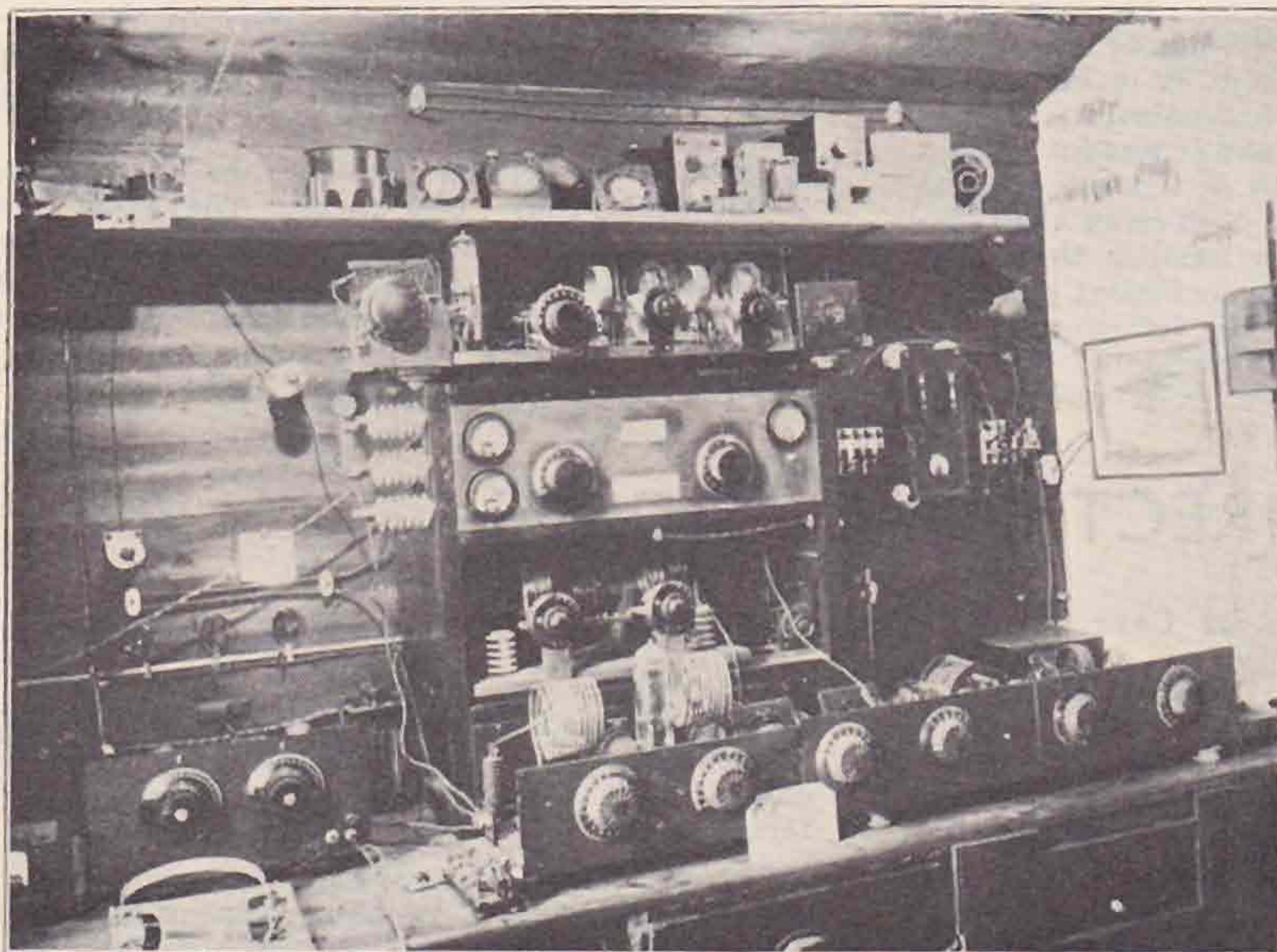

In photograph No. 1 at the top, under the shelf can be seen the 3.5 mc. transmitter. Various crystals may be selected by the rotary stud switch seen on the right. Immediately beneath this transmitter is a T.P.T.G. locked oscillator on 14 mc. The lead from the frequency doubler coupling coil can be plainly seen. The CO-FD-FD-FD portion is on the bench in front. Beneath the 14 mc. transmitter is the 28 mc. transmitter, which is another locked T.P.T.G., the SW/50 valve can be dimly seen behind the coils. The front transmitter is for 7 mc., although the 3.5 mc. transmitter may be used for this frequency by changing the coils, but as this is slightly less efficient, Goyder-lock is preferred. The 7 to 56 mc. receiver is shown on the left.

been stimulated several years previous to this. At this time the writer was living in the next road, about 250 yards away, and can remember hearing G6NF on the 440-metre waveband, though in those days never expected to be a transmitter himself, but followed his telephony with other local amateurs with great interest.

Since those days G6NF has developed his station till he is the owner of one of the premier stations in South London. A good score of DX can be credited to him, but like all serious amateurs he realises that the obtaining of W.B.E. and W.A.C. and increasing the number of countries worked is a long way from the ultimate aim of amateur work, and many of the other branches have been experimented with and knowledge of the subject thereby increased. Much time has been spent in obtaining high quality production from both radio and gramophone; the result of this is that telephony from the station often receives the report that it sounds like a B.B.C. transmission. The owner has for a long time past been working with frequency meter and matters connected with frequency checking, and nearly every time that I have visited

measurements on crystals and with the 100 kc. quartz bars in test tubes now has the appearance of a laboratory. By the door leading to the inner room, or "Holy of Holies" as it might be called, as the windows are kept closed to exclude the dust, is a large panel with an appearance of great age and having on it a variety of switches and transformers; what they all do, nobody but the owner knows, and I have a feeling that smoke would rise very quickly if anyone started to do things at random.

I am not aware of any other station that owns a separate transmitter for each waveband from 160 down to 5 metres, but G6NF believes in the idea, and it does make wave-changing easy, although I shall wait until I strike a gold mine before I follow this lead. On 1.7 mc. a crystal oscillator followed by a neutralised power amplifier is used, the input is 10 watts. For 3.5 mc. working CO-FD-PA is employed, this being quite separate from the 1.7 mc. transmitter. On 7, 14 and 28 mc. Goyder Lock is used. Separate T.P.T.G. oscillators and valves are used for each band, but the CO and the required number of frequency doublers are shared. For 56 mc. working the standard low power push-pull

circuit is used with a resonant grid circuit, and in tests has given good results in all directions except to the west. This is no fault of the transmitter, but is due to the rapid rise of ground in this direction; the writer lives on top of this hill, and as the wireless wave travels only five minutes walk from G6NF, yet stations on 56 mc. received here at R8 are quite inaudible. On all bands other than 1.7

for other bands O-V-1 with resistance capacity coupling is employed and converted to 56 mc. by the use of a separate valve for super-regeneration. It would take up too much space to describe all the other apparatus that can be seen on all sides.

All transmissions are monitored by a Hartley circuit monitor, and for test purposes gramophone music can be transmitted from a pick-up. A long

In photograph No. 2 we again see this receiver, with the two modulator valves to the left of it. The neon lamp is in an R.C. circuit, and serves to impulse a relay which is useful for sending out characteristic signals on 56 mc. To the left of this device is the 1.7 mc. CO-PA transmitter, which is little used in deference to the wishes of local BCL's. The 1.7-3.5 mc. receiver is on the extreme left of the photograph, and the 56 mc. transmitter is on the shelf at the top, and uses 2 B.T.H. B.12's in push-pull, handling up to 50 watts.

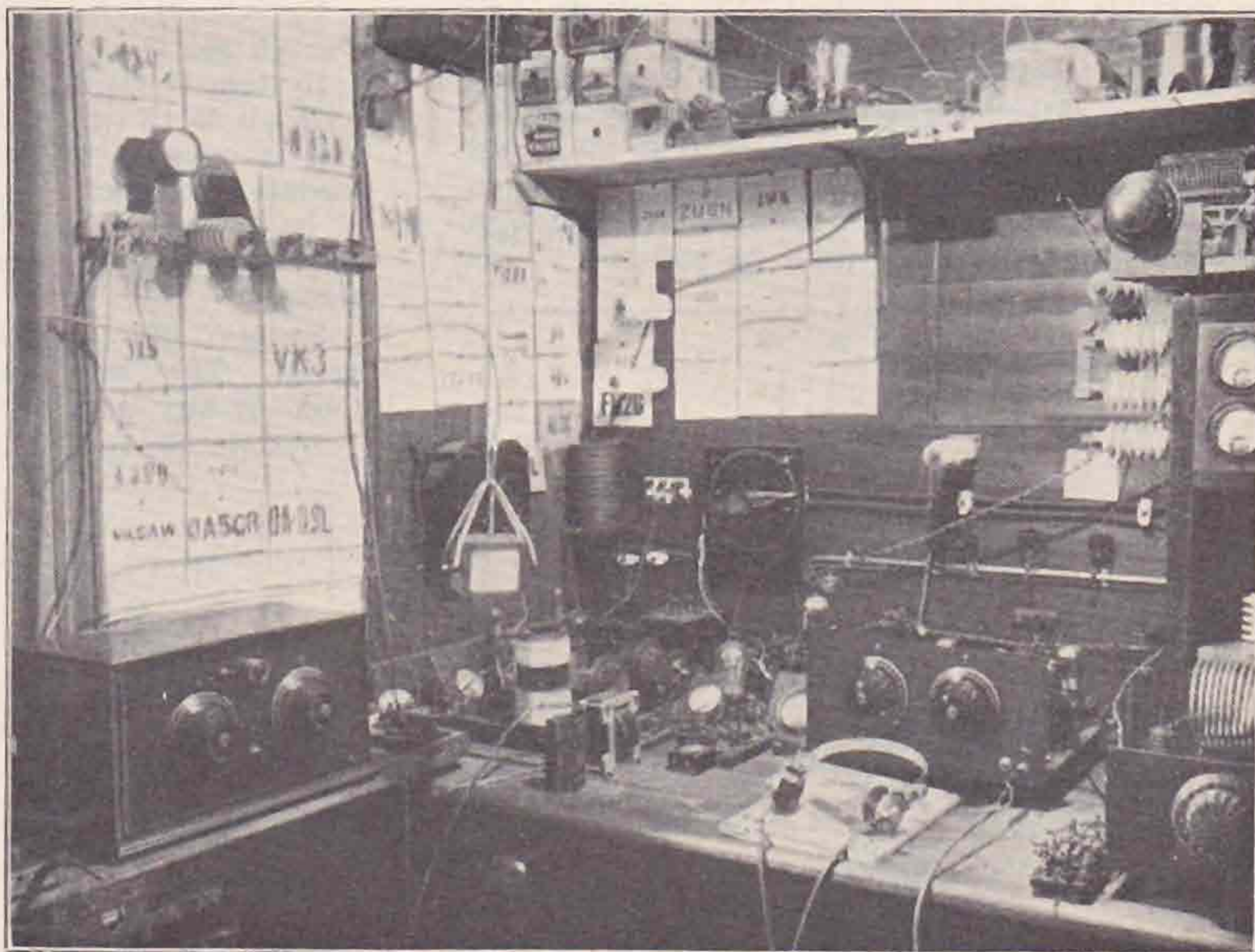

and 56 mc. powers up to 110 watts on C.W. and 30 watts on telephony are employed. GU1 rectifiers and primary keying are used, and for modulation two 50-watt valves in parallel; these are preceded by a 3-stage A.C. amplifier, and as a Reisz type microphone is used, this accounts for the excellent speech transmission that G6NF puts out.

For reception on 1.7 and 3.5 mc. an O-V-1 receiver with transformer coupling is used, but

wave receiver covers from 10 to 1,700 kilocycles and is used, among other things, in conjunction with a long wave frequency meter for observations on beats between 100 kc. crystals. Two ovens are used for experiments with frequency drift, one fitted with a mercury toluene thermostat, controls temperature to one-tenth of a degree C; the other is a simple oven for measuring the temperature coefficients of crystals, condensers, etc.

Valves in Parallel.

By J. H. WETHERILL (G2TK).

THIS short article has been written with the idea of bringing to the notice of the novice, who nowadays seems apt to be forgotten, a suitable way of obtaining increased input with the low-power valves already at his disposal.

As is generally known, whatever circuit is used, no further alterations than the insertion of another valve-holder and the necessary wiring of the valve are necessary. Parasitic oscillation, which seems more liable to occur with our present-day high efficiency modern valves when used in parallel, is easily cured by the insertion an H.F. choke, consisting of about 20 turns, on a 1-inch former, * in the grid lead to each valve-holder. If, however, the layout is made symmetrical, no trouble in this direction should be encountered.

The amateur using 220 volts on, say, a CT25X can obtain approximately 6 watts. When, however, two of these valves are used in parallel the voltage

can safely be raised to 350, whilst the input will rise accordingly to 12 watts or more. The input to each valve, however, still remains as before at 6 watts and as a result no over-heating occurs.

The advantages are, of course: (1) great stability, (2) slight increase in output for a given voltage, (3) greater input than the rating for a given voltage.

As mentioned previously, the chief object of these scant notes has been to revive in the minds of several amateurs an excellent way of obtaining greater stability and input with a minimum of trouble.

In conclusion, the use of valves in parallel has been found well worth while, solely for the purpose of improving tone if no greater input is required. In the writer's case, with unsmoothed D.C. on the plate, the tone has been reported improved from T7 to T9 CC, using two L.S.5 valves in parallel in a self-excited circuit.

[*This appears a little large. About 10 turns wound on a pencil, and then slipped off and left self-supporting, is frequently effective.—Ed.]

A UNIVERSAL AERIAL.

BY GUY H. GROSSIN (F8RJ).

F8RJ has a particularity which is unusual for a French station—that of an interest in all bands open to the amateur. Preference is, however, given to those bands on which it is possible to make frequent DX contacts, i.e., the 3.5, 7 and 14 mc. bands.

The aerial at F8RJ has therefore been designed to function satisfactorily on these three bands; further, it was considered necessary that the aerial should function in two or three different modes in each of these bands, in order that good radiation in practically any direction could be secured.

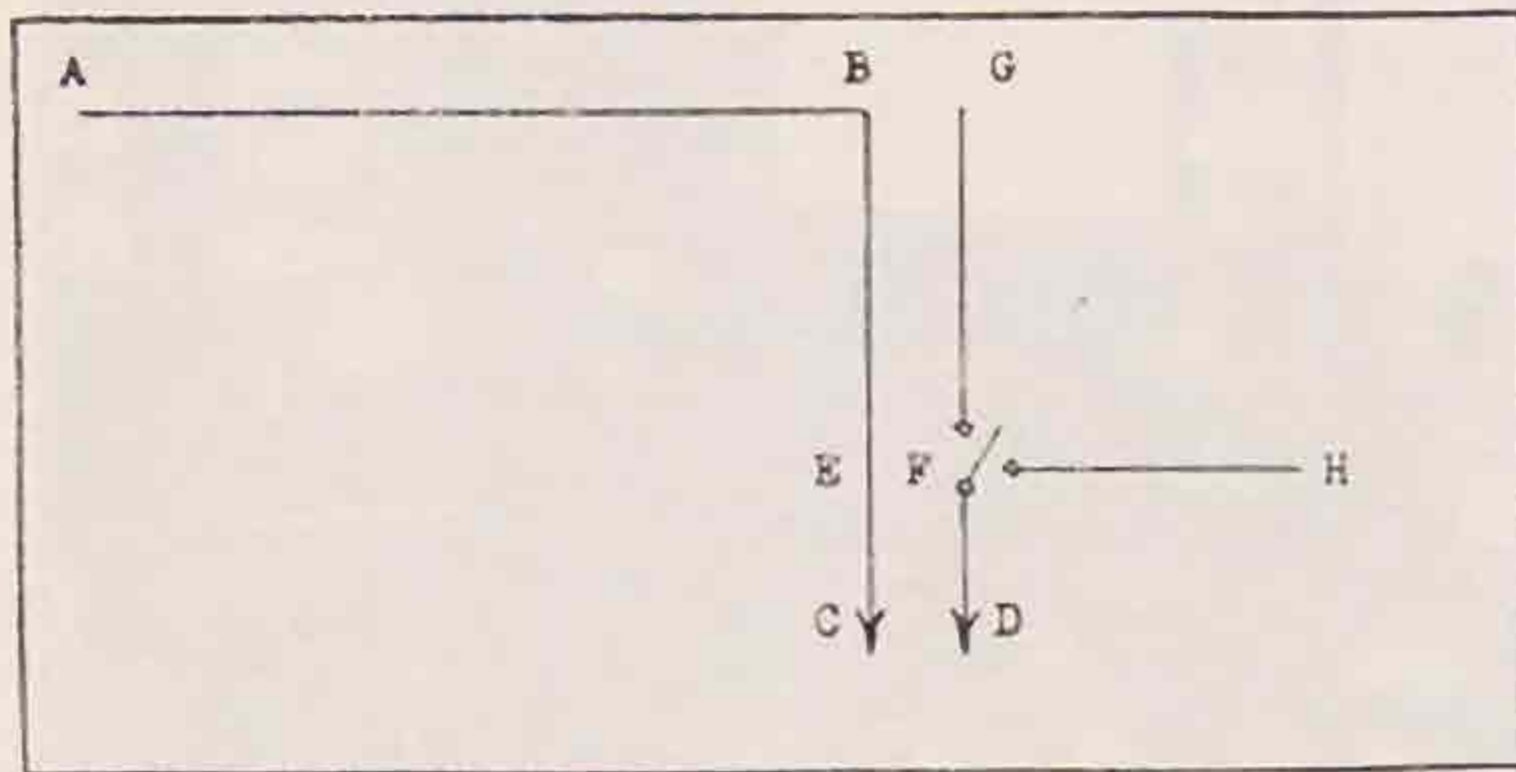

Fig. 1.—The Universal Aerial as used by F8RJ, the author of the accompanying article. Although designed for best operation on the 3.5, 7 and 14 mc. bands, it will also function on the 1.7, 28 and 56 mc. bands.

- A B—21m.
- B C—15m.
- D F—2.5m.
- F H—2.5m.
- F G—12.5m.

After several tests the aerial shown in Fig. 1 has been developed; it is a sort of Zeppelin, of which the roof measures approximately 21 metres, and the feeders about 15 m. At about 2.5 m. from the transmitter the second feeder is interrupted by a switch, which can be thrown over to a 2.5 m. indoor counterpoise.

We now describe the different modes in which this aerial can be excited.

On 14 mc.

System (1) corresponds to a normal Zeppelin, current fed, with a full wave radiator and $\frac{3}{4}$ wave feeders.

System (2) corresponds to a Hertz aerial oscillating in a double wave, and excited at its last current loop. The portions DE and CE, as in normal Zeppelin operation, do not radiate, and the part FH, being indoors, does not contribute greatly to the radiation; hence the effective radiation is from the portion ABE.

System (3) corresponds to a Fuchs aerial. The aerial tank coil is arranged with a voltage step-up, which increases the efficiency somewhat, and also allows the operating wavelength to be raised; with a normal Fuchs arrangement the optimum wave would be only 19.8 m. In this arrangement the whole length ABC radiates.

On 7 mc.

System (1) corresponds to a Zepp. with a half-wave horizontal radiator. The feeders are tuned to a quarter-wave by small series condensers.

In system (2) the whole aerial is excited at its natural wavelength; it is fed at a point midway between a current and a voltage node, and for this reason the efficiency is not very good.

System (3) is analogous to system (3) on 14 mc. On 3.5 mc.

System (1) is fairly complex. The portion GD, with an earth connection, oscillates in a half-wave, and is coupled by the capacity between the two feeders to the portion ABC, which is thus excited at a half-wave. The radiation from BC and DG mutually cancels, leaving AC as the effective radiator.

System (2) corresponds to a half-wave Fuchs aerial. The two variable tapplings permit of QSY to any part of the band.

System (3) is a voltage fed, half-wave Hertz.

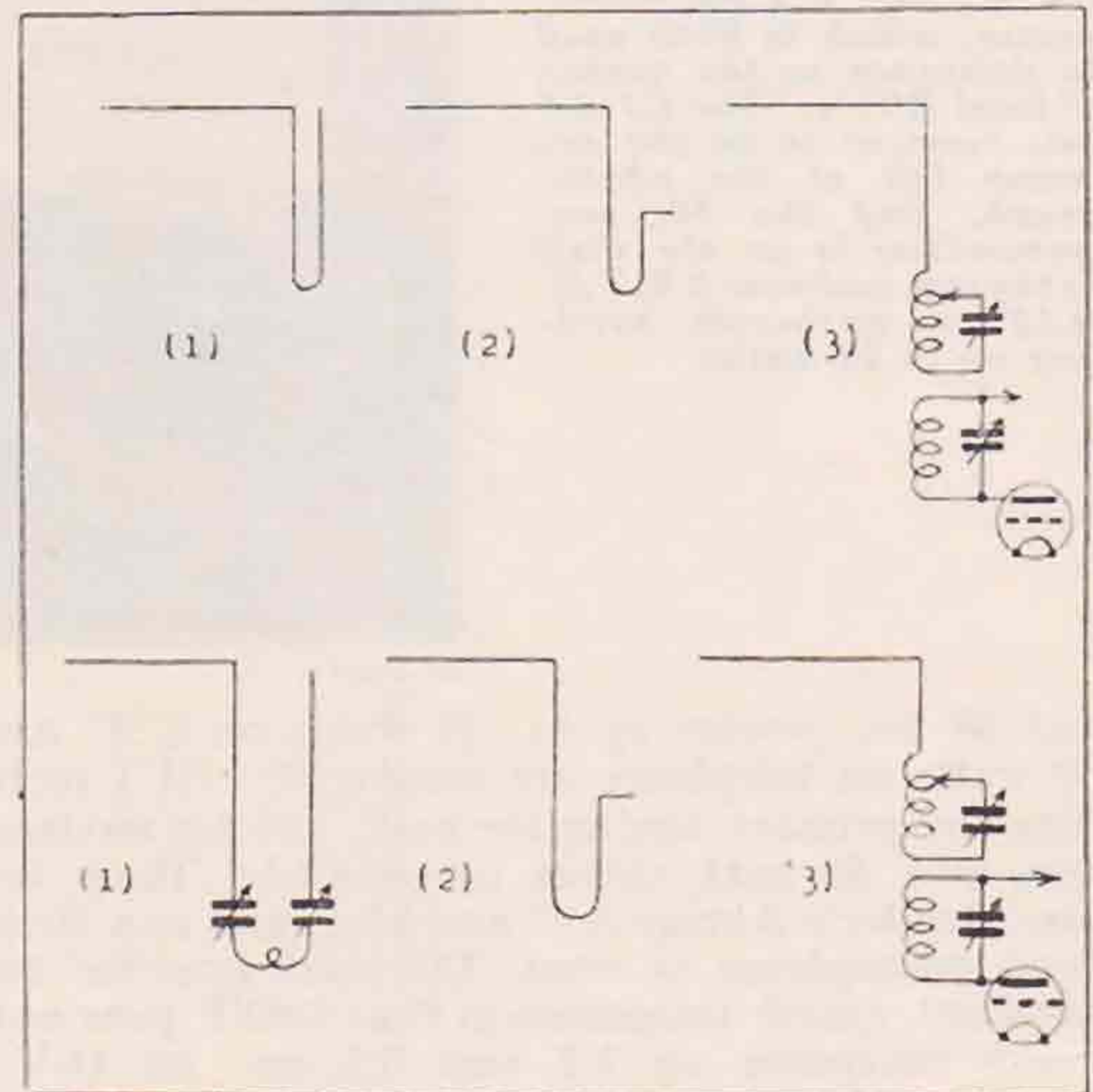

Fig. 2.—Modes of operation for the 14 mc. (above) and 7mc. bands.

On 1.7 mc.

Only one form of excitation is possible—a quarter-wave Marconi, i.e., the part ABC connected through a coupling coil to earth. By using different aerial coupling coils, QSY to any part of the band is easily possible.

On 28 mc.

System (1) is the classical Zeppelin. The radiating limb carries six half-waves, and the two feeders are oscillating at a quarter-wave. Thus the aerial is fed at a current loop.

System (2) is a kind of Zepp. The horizontal portion oscillates in a double wave; the two feeders each carry three half-waves, so that they have a current node at their lower ends, for which reason they are voltage fed.

On 56 mc.

System (1) is similar to system (2) on 10 m.

In system (2) the portion DFH constitutes a voltage-fed Hertz, and by virtue of the capacity

between the feeders it excites the portion ABC, which functions on a harmonic of very high order.

Conclusion.

This aerial is quite easy to operate. In each band it will resonate at several distinct points,

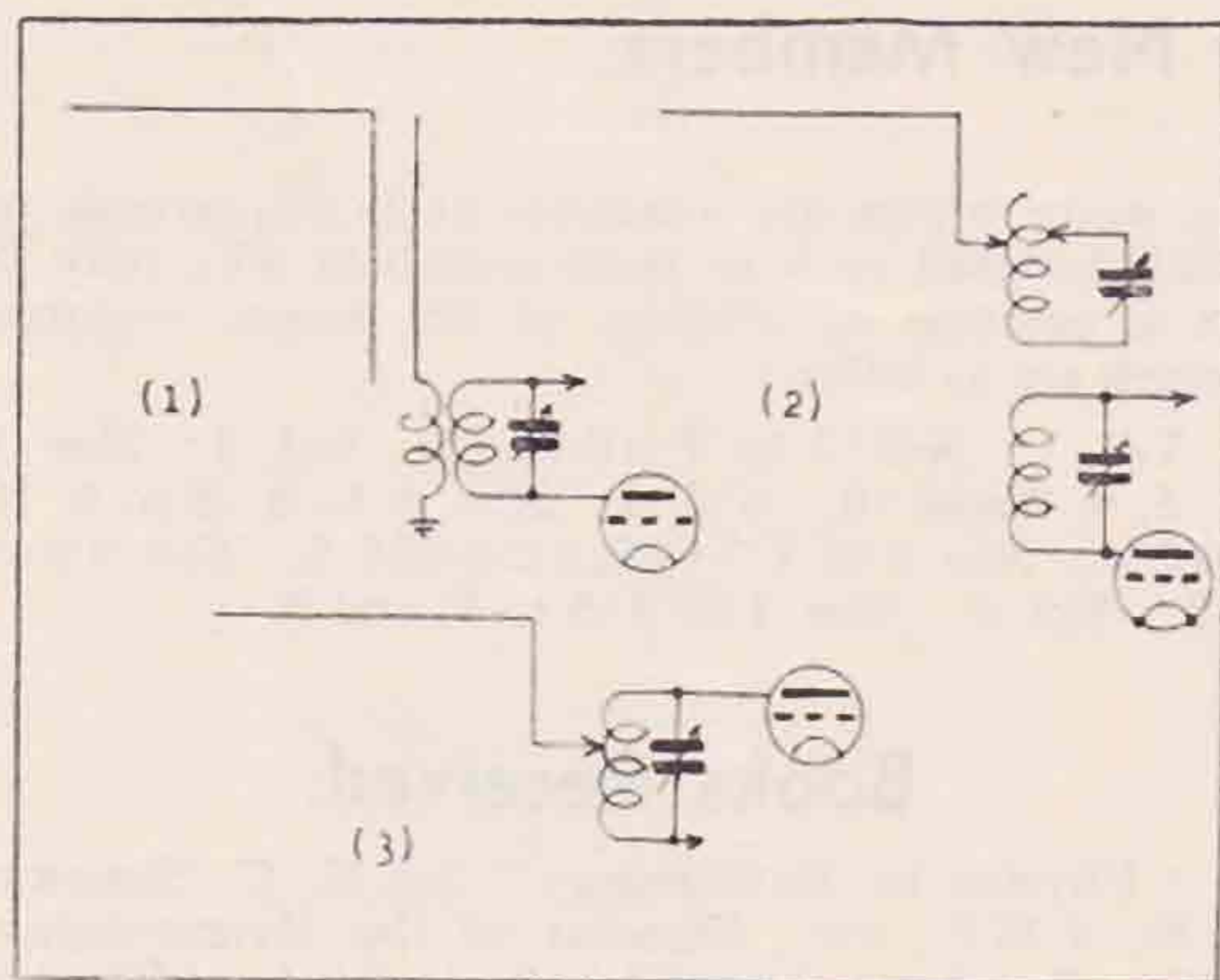

Fig. 3.—Operation on the 3.5 mc. band.

which allows certain forms of QRM to be obviated, and permits operation at the top or bottom of the band, according as a DX station called is known to be searching from one end of the band or the other.

The different radiations of the different arrangements are well marked at great distances. For example, on 20 m., system (1) gives good strength in W6, and poor in ZS, whereas system (2) gives exactly the reverse result.

Reasoned use of this aerial has allowed F8RJ greatly to increase his DX contacts. The licenced maximum input is 100 watts, but more than 50 watts are rarely used. In twelve months of traffic, 140 countries have been worked, which

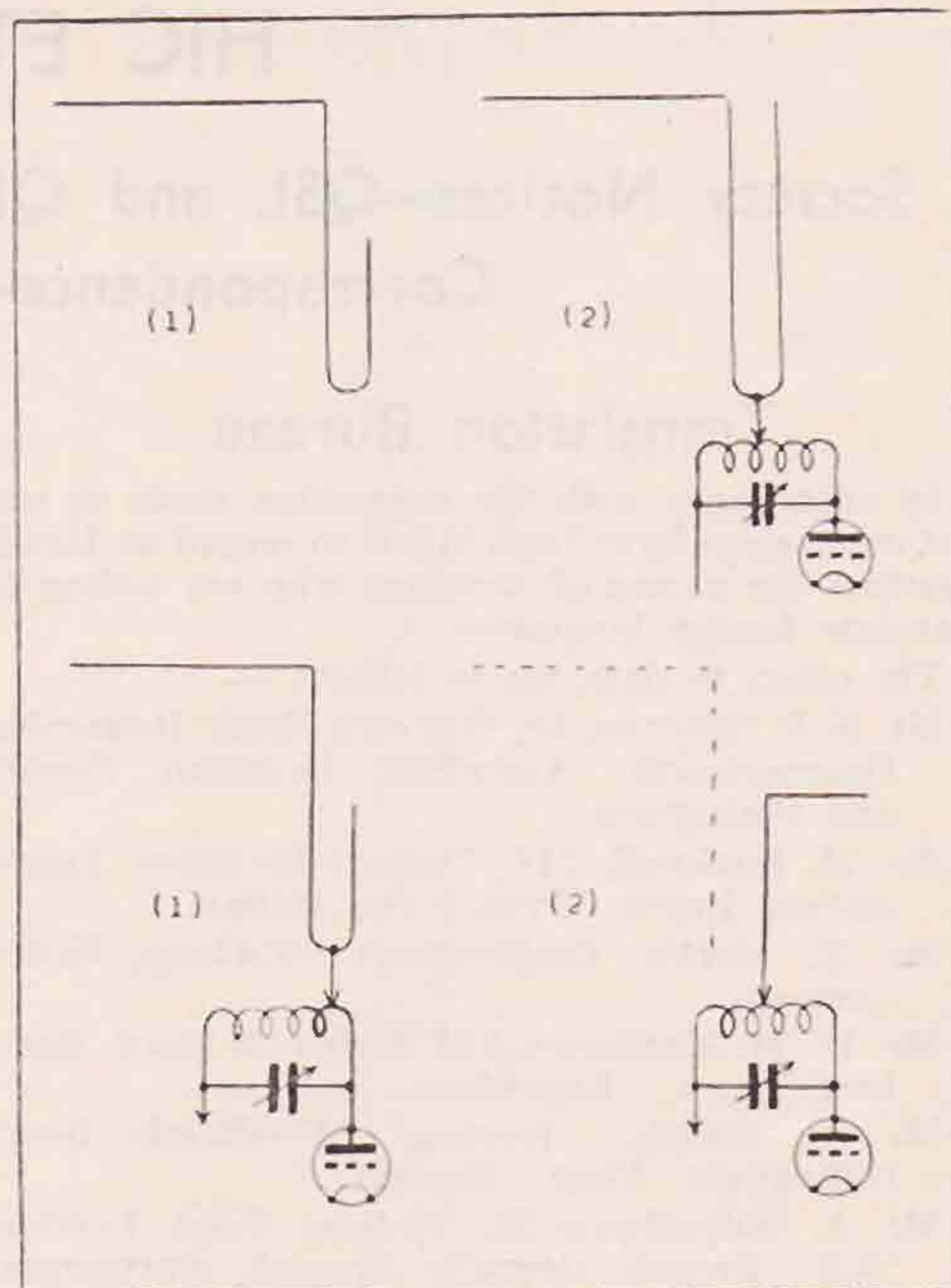

Fig. 4.—Operation on the 28mc. (above) and 56mc bands.

nearly equals the world record held by F8PZ—some 150 countries and . . . several hundred watts.

In conclusion, I wish to thank G6FY, who has kindly translated this article, which I could not have written in such good English—a language I have learnt entirely by radio.

CONTEST THOUGHTS.

We should like to know :

Where the op. behind the key at SU6HL learnt his Morse ?

How many stations not a hundred miles from South London remained " in lock " for the duration.

Whether G5ML, 6PY and 6XQ knew their ground wave signals were as strongly received in London during the Junior as they were during the Senior event ?

Whether G6UN is to go down in Amateur Radio history as King Watty of Beru ?

What is the population of Beru and how many " hams " live there ?

How long is a Test B.E.R.U. Call ?

In what part of the Empire is AU, and whether several London stations have forgotten their geography ?

Whether a W.B.E. was won inside the hour ?

Whether heavily modulated c.c. is quite fair ?

Whether ZL4AI ever sleeps ?

Whether QRZ was known before the Contest, and who started the fashion ?

Whether VK7CW still calls EG ?

Whether YI6BZ trains canaries to chirp on 14 mcs. ?

Who was the ham who said, after the fourth week-end, that he'd " Heard two BERU stations, but couldn't raise either of them, so packed up ? "

How many DX stations can read the 75 m.p.h. test calls from G6—?, and if he knows that his call-sign sounds like four long dashes ?

How many stations forgot about the Contest until late on Friday, February 3, and whether they all live in Cornwall ?

Whether the feathery part on the end of G6CL's tail stood up on end, and waved in the wind when he W.B.Ed twice in one week-end ?

Who was the G who called " test " 11 times and B.E.R.U. 39 times without signing ?

Why the rest of Europe started to call " test ? "

How G6HP hears VK's on 7 mc. on Sunday evenings ?

Why the 7 mc. band always seems wider on Sundays ?

What does " G " think about the " F " fone ?

What the DX people think about primary keying ?

Who was using his licensed power ?

What did G5ML think after hanging on to a QSA2 signal calling him for 10 minutes and signing OZ ?

HIC ET UBIQUE.

Society Notices—QSL and QRA Sections—Empire Calls Heard— Correspondence—Our New Members.

Translation Bureau.

In accordance with the suggestion made in our last issue, steps have been taken to record at Headquarters the names of members who are willing to translate foreign languages.

The offers to date are as follows:—

Mr. N. P. Spooner, 18, Warwick Road, Boscombe, Bournemouth. Argentine, Brazilian, French and Portuguese.

Mr. M. Buckwell, 114, Tankerville Drive, Leigh-on-Sea, Essex. French and Italian.

Mr. E. Martin, Castlemount, Worksop, Notts. German.

Mr. W. H. Matthews, 132, Hainault Road, Romford, Essex. Esperanto.

Mr. R. Smith, "Keston," Woodlands Road, Gillingham, Kent. French.

Mr. A. Wilberforce, 55, Madeley Road, London, W.5. French, German, Spanish, Portuguese, Swedish and Norwegian.

Mr. Matthews offers to have translated any radio matter which cannot be dealt with by other members, providing postage expenses are paid. He proposes to effect this by sending the matter to be translated to an Esperantist in the country of origin, who will be asked to convert the matter into Esperanto. This will then be returned to Mr. Matthews, who will translate the Esperanto into English.

New York Public Library.

We have received a request from the above library for certain back issues of the BULLETIN. As

no spare copies are available at headquarters, we shall be glad to hear from members who may be in a position to dispose of the issues required, which are as follows:—

Vol. 1: Nos. 1 to 7, 10 to 12. Vol. 2: Nos. 1, 3, 5, 6, 8 and 10. Vol. 3: Nos. 1 to 3, 5 to 9, 12. Vol. 4: Nos. 1 to 5, 7 to 9, 11. Vol. 5: Nos. 3 to 8, 12. Vol. 6: Nos. 1 to 3, 5 to 7, and 9.

Books Received.

"Physics in Meteorology," by G. C. Simpson, C.B., C.B.E., etc., Director of the Meteorological Office, London. Issued by the Institute of Physics, 1, Lowther Gardens, London, S.W.7.

"Rubber Latex," issued by The Rubber Growers' Association, Inc., 2, Idol Lane, London, S.E.3.

Both of these books are available at headquarters for loan to members on receipt of postage.

Commercial Interference.

The Society has taken up the question of commercial interference on the 7 and 14 mc. bands from stations HAT and HAS. It has been pointed out that although these stations are actually operating outside our bands, the heavy modulation of their carrier waves produces serious interference to amateur working.

The attention of the G.P.O. has also been drawn to the continued interference from certain Italian stations operating in the 7 mc. amateur band.

In all of these cases action is being taken.

QSL Section.

There has naturally been some commotion amongst non-members as a result of the announcement in these notes last month, and although one may, no doubt, feel sorry for the people who can no longer get something for nothing, it is obvious that the privileges the Society is able to offer should be exclusively reserved for its members. The Society has to pay its staff and postage expenses, and it is only fair that the work should be done for those who contribute to its upkeep.

It is not our wish to be vindictive to non-members, but at the same time it is strongly felt that many have not joined as they were receiving the benefits of membership free of charge, and therefore it was deemed advisable to make the QSL service available to members only. That this assumption was justified is indicated by the fact that no fewer than eight non-members who were frequent users of the section have now joined the Society.

There is nothing definite to report concerning the A.R.R.L. and the B.R.S. cards, although we have been informed that experiments with the district QSL scheme are proceeding satisfactorily, and before long it may prove possible to reinstitute the service for B.R.S. cards.

In spite of the fact that the above matter is mentioned monthly in these columns, we are still receiving a large number of cards from B.R.S. and A.A. members for distribution to W., V.E. and associated A.R.R.L. stations. *Will B.R.S. stations therefore note that for the present we are unable to accept listening reports for A.R.R.L. Stations?* For the benefit of newer members we therefore reprint a list of prefixes to whom we cannot forward receiving reports: CM, HC, HH, HI, HR, KA, K4, K5, K6, K7, OM, TI, VE, VO and X.

J. D. C.

ROLA

the World's Finest Reproducers

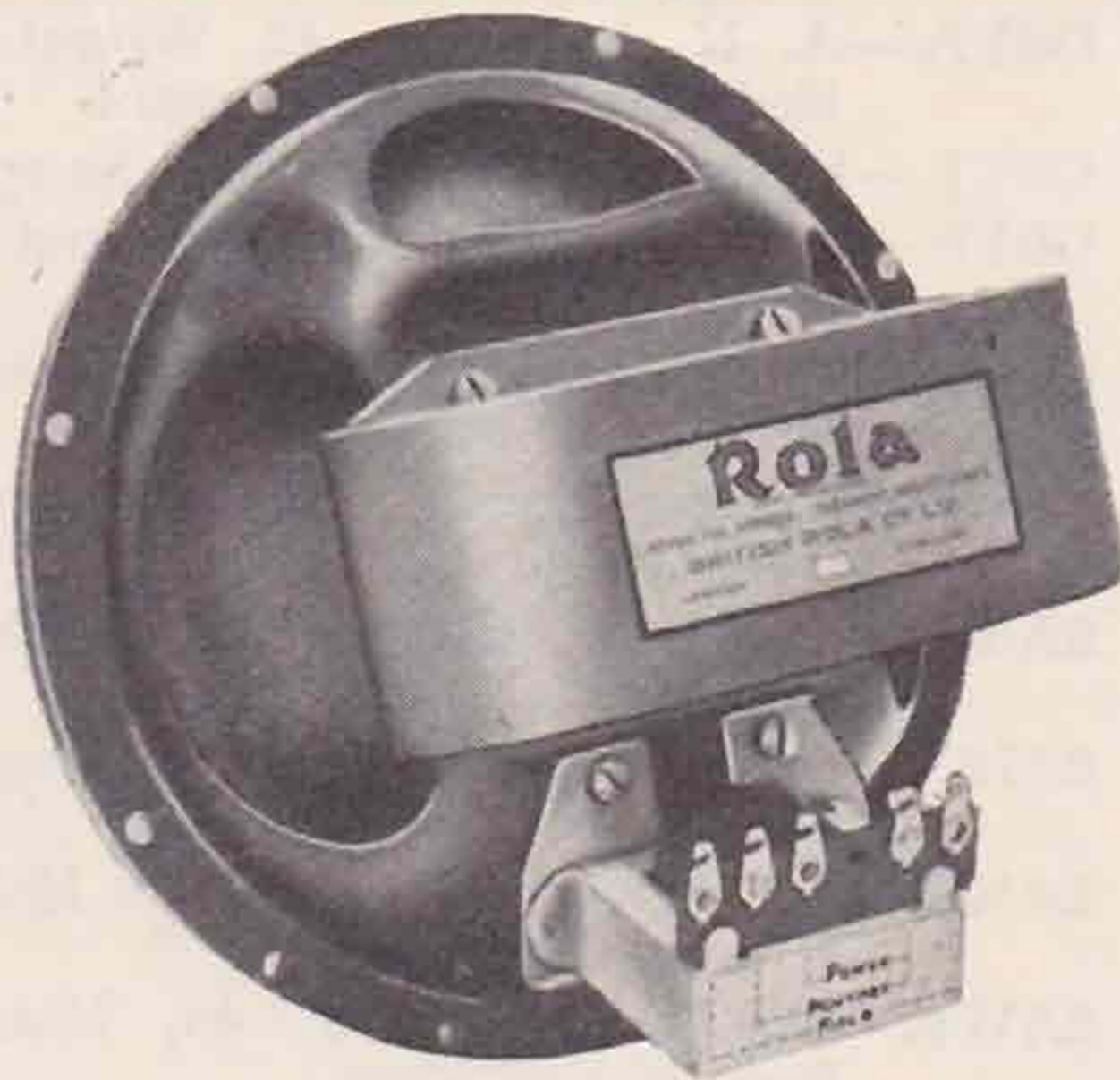

Because of the acknowledged superiority of their realistic reproduction, Rola Speakers are used by the large majority of Radio Manufacturers, and specially recommended by the designers of the following 'Constructor Sets':

- "WIRELESS WORLD" RECEIVERS.**
- MODERN A.C. QUALITY AMPLIFIER.**
Rola Dual Balanced Pair, consisting of one F6-2500 and one F7-2500 Speaker with 00B Transformer.....£4 5s.
- A.C. MONODIAL SUPER.**
Rola Type F6-2500 35s.
or Dual Balanced Pair F6-2500 and F7-PM with Class 00B Transformer £4 12s. 6d.
- MODERN STRAIGHT FIVE AMPLIFIER.**
Same as A.C. Monodial Super.
- BABY SUPER.**
Rola Type F6-P2500 35s.
- "WIRELESS CONSTRUCTOR" A.C. S.T. 400.**
Rola Special Model F6-S.T. 400 35s.
- "WIRELESS MAGAZINE" RECEIVERS.**
- WORDS AND MUSIC RADIOGRAM DE LUXE**
Rola Type F5-PM 32s. 6d.
- A.C. QUALITY GEM**
Rola Type F6-P2000..... 35s.
- WORDS AND MUSIC Q.P.P. RADIOGRAM.**
Rola Type F5-PM 32s. 6d.
- "AMATEUR WIRELESS" RECEIVERS.**
- PUSH-PUSH AMPLIFIER**
Rola Type F6-PM-QPP-22A 49s. 6d.
- JAMES PUSH-PUSH 3**
Rola Type F6-PM 49s. 6d.
- EVERYBODY'S HOME RADIOGRAM**
Rola Type F6-PM-1 49s. 6d.
Etc. Etc.

THE BRITISH ROLA CO., LTD.
Brondebury Works, 179, High Road, Kilburn
Telephone: MAIDA VALE 5017-8-9. N.W.6

ROLA
SPEAKERS
for better
Radio Reception

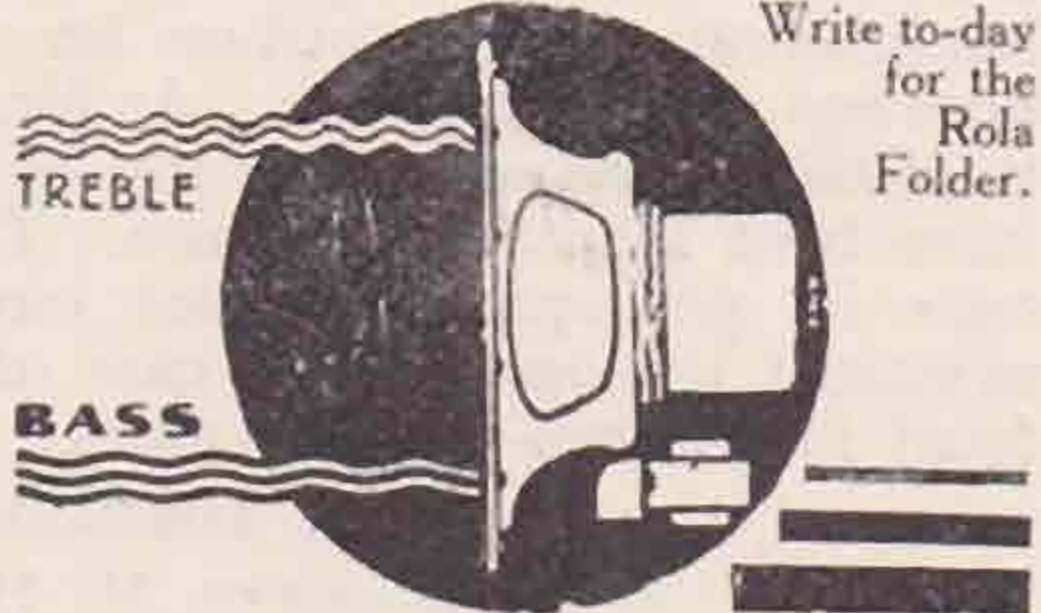

Write to-day
for the
Rola
Folder.

COLVERDYNE INTERMEDIATES

for the
'ALL-MAINS SHORT WAVE SUPER-HET.'

Maximum efficiency obtained by the use of Colverdine Intermediates. *
Limited range adjustment to compensate for stray circuit capacities.
Variable coupling is provided by sliding moving coil up and down its pillar, the band pass effect being adjusted to any desired degree, maximum amplification is therefore obtained.

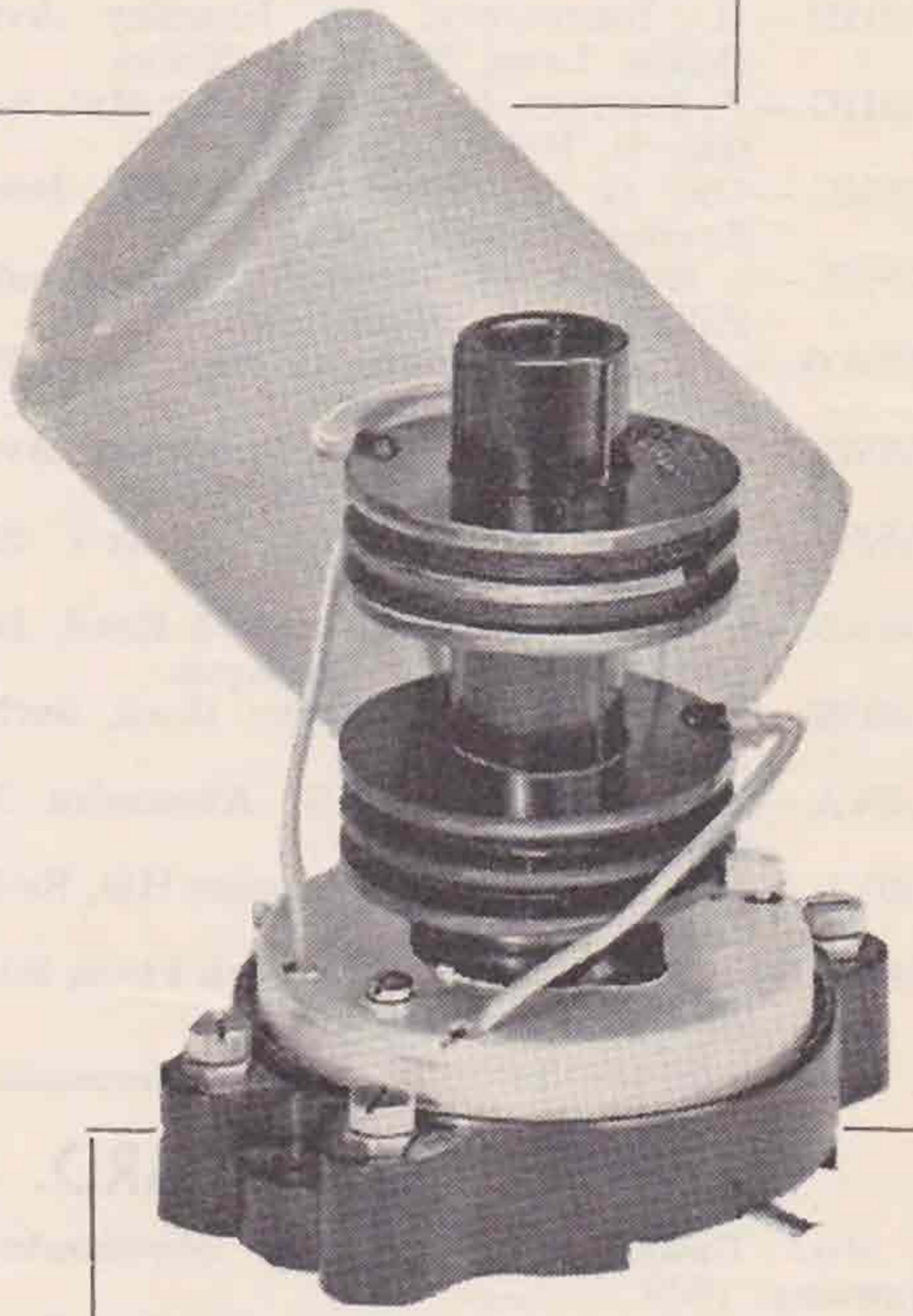

For the Five Valve All-Mains Short Wave Super-Het . . .

2	Colverdine Intermediates, Type 110 @	12/6
4	Colvern Coil Formers, Type CF @	2/6
2	Colvern 6 pin Bases, Type TBS @	2/-
2	Colvern Screening Covers, Type CCS @	3/6

COLVERN LTD
ROMFORD ESSEX

QRA SECTION.

Manager: M. W. PILPEL (G6PP).

G2AZ.—L. GRECH, 27, Harden Place, c/o Ainslie, Edinburgh, 11.
 G2CL.—M. F. LONG, 32, South Parade, Summer-town, Oxford.
 G2CT.—R. W. PEEL, 24, Temple Grove, Golders Green, London, N.W.11.
 G2CY.—H. W. STEWART, 24, Kynaston Road, London, N.16.
 G2DF.—F. A. VOST, 26, Pinewood Avenue, Warrington, Lancs.
 G2QH.—C. HEWINS, Sunnyside, Fairfield Avenue, Scarthoe, Grimsby, Lincs.
 G2ZJ.—W. A. NOKES, Station Road, Wroxham, Norwich.
 G5CL.—M. SHAW, 13, Brian Road, Smethwick, Staffs.
 G5HB.—H. BILTCLIFFE, 19, Kingsley Avenue, Bolton Lane, Bradford, Yorks.
 G5HG.—F. ILLIDGE, Harcourt, Bleak Hill, Eccleston, St. Helens, Lancs.
 G5MG.—DR. G. F. BLOOMFIELD, 27, Belmont Avenue, London, N.17.
 G5SR.—S. RIESEN, 44, Wood End Road, Sudbury Hill, Harrow, Middlesex.
 G5WG.—W. E. CORBETT, Gorse Hey Hotel, Bebington, Cheshire.
 G5WQ.—J. R. WITTY, 11, Dominion Avenue, Chapel Allerton, Leeds, Yorks.
 G5ZU.—R. H. JACKSON, 54, Prince's Street, Stockport, Cheshire.
 G6NN.—C. V. WOOD, 48, Westfield Road, Barnehurst, Bexley Heath, Kent.
 G6PK.—W. G. PYKE, 19, Grove Road, Surbiton, Surrey.
 G6VA.—E. J. PICKARD, 107, Alexandra Road, Croydon, Surrey.
 G6VF.—L. E. CRABBE, 13, Luccombe Hill, Redland, Bristol.
 G6VI.—W. A. MACCALLUM, 21, Park Place, Stirling, Scotland.

G6VR.—J. L. B. CHARLESWORTH, 69, James Street, Barnsley.
 G6WM.—R. H. ROLINGS, 25, Dawes Street, Gillingham, Kent.
 G6XM.—W. JAMES, 28, Grant Square, North Camp, Aldershot, Hants.
 G6YA.—A. H. RADFORD, 42, Wrington Crescent, Bedminster Down, Bristol.
 G6YJ.—F. R. CANNING, Crindau, Newport, Mon.
 G6YS.—S. C. BAVEYSTOCK, "Benoni," 29, Long Lane, London, N.3.
 G6YT.—W. S. TURPIN, 1, Austin Avenue, Stockton-on-Tees, Durham.
 G6ZV.—J. HUNTER, 51, Camphill Avenue, Langside, Glasgow, S.1.
 2AAR.—V. H. S. CURLING, 175, Dover Road, Northfleet, Kent.
 2AIS.—C. J. PAISH, Well Street, Stow-on-the-Wold, Glos.
 2AKA.—B. ROWELL, 14, Market Hill, St. Ives, Huntingdonshire.
 2AWK.—L. G. BLUNDELL, 45, Monivea Road, Beckenham, Kent.
 2AWX.—E. JENKINS, Lenton, Victoria Terrace, Aberystwyth, Cardiganshire.
 2BCQ.—J. DALTON, 13, Grove Street, Whitby, Yorks.

The following are cancelled: G5HA, G6IS, 2AHX, 2ARV, 2ASG, 2AVR, 2BAF, 2BDT, 2BKH, 2BRA, 2BRG, 2BRP, 2BVJ, 2BWC, 2BXT, 2BXW, 2BYB.

PLEASE NOTE.

In future will members please send all new QRA's, changes of address, etc., to:—

QRA Manager,
 R. S. G. B.,
 53, Victoria Street,
 London, S.W.1.

EMPIRE CALLS HEARD.

Miss Dunn, G6YL, Felton, Northumberland. January, 1933.

7 mc.: vk2pe, 2sg, 3bq, 3dt, 3lp, 3sq, 3wl, 6gf, xulu, zelesa, zeljf, zslc, 2f, 4f, zt2h, 2l, zulp, zu6a.

14 mc.: ve2fs, 3de, 3wa, k2va, 2fq, 2fy, 2gw, 2hw, 2lx, 2lz, 2xu, 2xy, 3bj, 3bv, 3bw, 3gq, 3jj, 3mr, 3wl, 4gk, 5gr, 5mf, 5my, 5wp, vu2ah, zslh, zs4m.

* * *

E. A. Haskell, BERS134, Telegraphist, H.M.S. "Royal Sovereign," Mediterranean, November, 1932.

7 mc.: g2mc, 5hb, 5nf, 5np, 5oj, 5pl, 6fn, 6gq, 6nd, 6rb, 6tf, vk3wr.

* * *

G. B. Wild, BERS59, Ras-el-Tin, Alexandria, Egypt.

g2ak, 2by, 2im, 2io, 2ga, 2nh, 2od, 2rm, 2tr, 2yc, 2yl, 2yx, 2zq, 5hj, 5ku, 5ml, 5sg, 6gs, 6hp, 6li, 6pm, 6qb, 6uf, 6vp, 6wq.

CORRESPONDENCE.

The Editor does not hold himself responsible for opinions expressed by correspondents. All correspondence must be accompanied by the writer's name and address, though not necessarily for publication.

Modulation.

To the Editor of THE T. & R. BULLETIN.

DEAR SIR,—I have to thank Mr. Clark for drawing attention to the error in my article on Modulation. The condition for maximum current does not, of course, arise. As Mr. Clark points out, it could not have been a slip of the pen—it must have been mental aberration. The analogy of the cells is, perhaps, somewhat cumbersome. It is sufficient to consider the case of an alternator of fixed impedance working into a load.

I am, Yours faithfully,
 ALEXANDER M. HARDIE (G5FP).

OUR NEW MEMBERS.

This month Council had the pleasure of electing over fifty new members, including several outstanding personalities in the Radio World. We make no apology, therefore, for recording a few comments regarding the activities of these gentlemen.

Lieut.-Colonel Scarlett, D.S.O., who for many years was the secretary of the Golders Green Society, and has now succeeded to the presidency of that body, is but one of a long list of distinguished Service officers who have devoted much time and thought to the amateur cause. His election to membership will provide a closer link between the R.S.G.B. and one of the most progressive local societies.

Captain Benn Wallich, of St. Ives, Cornwall, was for several years in the Intelligence Service, and in 1923 joined the B.B.C. as personal assistant to Mr. Arthur Burrows (Director of Programmes). He was later appointed Director of the Plymouth B.B.C. Station, and in 1926 became director of the Calcutta Station of the Indian Broadcasting Company. For the past few years Captain Wallich has been carrying out experimental work in connection with television.

Mr. John Grinan—who does not remember him as NJ2PZ in the early days of short-wave amateur radio? His enrolment gives us added pleasure, because of his personal association with such pioneers as Armstrong, Godley and Schell. Mr.

Grinan holds the first pre-war American trans-continental relay record when he was operating as 2PM. He was also one of the operators at IBCG Greenwich, Connecticut, during those never-to-be-forgotten 1922 tests, when the first American amateur signals were heard in Ardrossan, Scotland, by Paul Godley, of the A.R.R.L. He was one of the earliest holders of a W.A.C. certificate, and we have reason to believe it will not be long before VP5PZ, his new Jamaican call, will be as well known as were the many others which have been tapped out by his skilled hand in days gone by.

Mr. S. R. Wright, G2DR, one of the earliest provincial officials of the R.S.G.B., has staged a come-back into the amateur field. Mr. Wright's activities are legion and the news of his return will be warmly received by all who can class themselves "old-timers."

From Mauritius comes the news that the whole amateur fraternity have joined the B.E.R.U., and so one more spot on the map at headquarters becomes "occupied."

Following the election last month of H.H. Prince Temenggong Ahmad, the State Commissioner of Muar, Johore, we have to record the enrolment of Senor Placid de Souza, the Portuguese Vice-Consul in Dar-es-Salaam.

To all of these gentlemen and to the others whose names are appended, we extend a sincere and warm welcome into our Society.

HOME CORPORATES.

P. B. BURNETT (G2BL), Longmead, Winscombe, Somerset.
 W. A. D. HOWES (G2CF), Drummers, Windmill Hill, near Hailsham, Sussex.
 S. R. WRIGHT (G2DR, 5QR), Greenway, Lees Road, Bramhall, Cheshire.
 J. H. GEORGE (G2FH), 10, Aultone Way, Sutton, Surrey.
 A. C. HOLMES (G2VO), 40, Aire View, Cononley, Keighley, Yorks.
 A. C. TAYLOR (G5CT), 5, Nab Wood Mount, Shipley, Yorks.
 F. P. HILLIER (G5XZ), 8, Denehurst Gardens, Hendon, N.W.4.
 W. JONES (G6OK), 14, Station Road, Colwyn Bay, N. Wales.
 W. E. G. BRIGDEN (G6WU), Aberfoyle, Westleigh Avenue, Leicester.
 A. PEMBERTON (2AJO), 57, Tillotson Road, Heeley, Sheffield.
 G. A. SWINNERTON (2BJR), 109, Shireland Road, Smethwick, Staffs.
 K. B. ROULSTON (2BVN), 5, Pine Tree Avenue, Humberstone, Leicester.
 A. BOA (2BQL), 4, Tewkesbury Terrace, New Southgate, N.11.
 C. H. ISON (2BWT), 47, Orford Road, Walthamstow, E.17.
 R. W. ROBERTS (BRS1073), 14, Well Street, Ruthin, Denbighshire.
 S. G. KITCHEN (BRS1074), 12, Chester Street, Bradford, Yorks.
 H. C. LOWE (BRS1075), Gethceln, Dawley, Hayes, Middlesex.
 A. J. ELLIS (BRS1076), c/o Wallace, 56, White Street, Glasgow, W.
 REV. L. C. HODGE (BRS1077), 4, Tunnard Street, Boston, Lincs.
 A. W. BLOOMER (BRS1078), 70, Long Street, Dordon, Tamworth, Staffs.
 G. KNEWSTUB (BRS1080), 28, Fairmead Road, Tufnell Park, N.19.
 A. H. D. LLEWELLYN (BRS1081), "Wycliffe House," Lewisham Park, S.E.13.
 D. M. MACLAREN (BRS1082), 36, Holmhead Road, Cathcart, Glasgow.
 R. A. D. MEHAREY (BRS1083), Meadowbank, Whitehouse, Belfast.
 A. H. PEACOCK (BRS1084), 7, Jubilee Terrace, Ditton, Kent.
 LIEUT.-COL. H. ASHLEY SCARLETT, D.S.O. (BRS1085), 60, Patterson Road, Hampstead, N.W.2.

W. A. L. SMITH (BRS1086), 55, Cadogan Terrace, Victoria Park, E.9.
 G. A. SWAN (BRS1087), 3, Ravensworth Crescent, Kells Lane, Low Fell, Gateshead-on-Tyne.

CAPT. B. WALLICH (BRS1088), Chy-an-Veor, St. Ives, Cornwall.
 H. WRIGHT (BRS1089), 95, Helston Road, Penryn, Cornwall.
 E. H. LEAMON (BRS1090), 250, Dalston Lane, E.8.
 K. C. CAMPBELL, jun. (BRS1091), The Hawthorns, Moss Lane, Pinner, Middlesex.

W. ROBERTSON (BRS1092), 41, Lilybank Crescent, Forfar, Scotland.
 L. W. DOUGLAS (BRS1093), 3, Queen's Parade, Faversham, Kent.

DOMINION AND FOREIGN.

R. DUBS (F8FR), 16 Rue Reichenstein, Mulhouse, France.
 E. H. L. MAZERY (VSAB), Box 101, Port Louis, Mauritius.
 G. KOENIG (VSAC), Rose Hill, Mauritius.
 V. DE ROBILIARD (VSAF), Box 163, Port Louis, Mauritius.
 R. F. PEACOCK (VE1CY), 49, Spring Street, St. John, New Brunswick, Canada.
 J. F. GRINAN (VP5PZ), P.O. Box 5, Kingston, Jamaica, B.W.I.
 G. WILDE (VS2AD), c/o Posts and Telegraphs, Ipoh, F.M.S.
 A. B. NELSON (W1AYR), 163, High Street, Bristol, Conn., U.S.A.
 W. G. LEYLAND (ZE1JM), B.S.A. Police, Umtali, S. Rhodesia.
 H. G. CUNNINGHAM (BERS161), Tel. H.M.S. Royal Sovereign, c/o G.P.O.
 M. R. COGHAN (BERS162), Moongalaar Estate, Vandiperiyar, Travancore, S. India.
 G. S. GILLIES (BERS163), Munnar P.O., Travancore, S. India.
 M. R. DURMAN (BERS164), 4 Flight, 31 (AC) Squadron, R.A.F., Quetta.
 M. GOODINSON (BERS165), W/T Section, No. 203 Squadron, R.A.F., Basrah.
 HON. P. ADAM, O.B.E. (BERS166), Port Louis, Mauritius.
 PLACID DE SOUZA (FRS17), Box 50, Dar-Es-Salaam, Tanganyika Territory.
 J. F. JUNIET (FRS18), Ingenieur T.P.E., Paimboeuf, Loire, Inferieure, France.

Around Europe.

Mr. Sawell, CT1BK, our representative in Portugal, advises us that the first organised REP Contest proved successful, but unfortunately conditions on the 7 mc. band were not good. The C.C. stations obtained the most satisfactory results.

The R.E.P. Annual report showed that considerable progress has been made, a regular periodical

is now published, and a permanent assistant appointed to deal with the increasing correspondence.

Station CT1KC, installed in the Geophysical Institute at Coimbra, is transmitting a weather report giving velocity and direction of the wind daily at 11.00 G.M.T. on 7 mcs. Six groups of five letters are sent in accordance with the International Meteorology Code; reports are requested.

THE R.A.F. FLIGHT AND THE MOUNT EVEREST EXPEDITION.

Two instances have occurred recently whereby our members have been able to render valuable assistance to important national projects. We refer firstly to the successful R.A.F. Flight to South Africa, and secondly to the Mount Everest Expedition.

It will be remembered that as far back as November, 1931, we were requested by the Air Ministry to arrange for a chain of amateur stations to stand by during the non-stop flight. Various circumstances prevented the flight commencing before February 6 of this year, but for months beforehand Mr. Miles, G5ML, and Mr. Auret, ZU6W, had maintained a daily schedule in order to set the machinery into action as soon as advice was received from the Air Ministry. As we know now, the call to action came early on the morning of February 6. Immediately G5ML linked up with ZU6W and the whole of the S.A.R.R.L. emergency network went into operation.

At the same time several of our home members began a long and tedious watch, in order to intercept signals from GEZAA, but with two exceptions the signals do not appear to have been logged by amateurs in this country, although the Air Ministry were able to maintain touch until the aircraft was well over Northern Africa.

The two successful members were Mr. Clarke, G5FV, of Keyingham, near Hull, and Mr. A. Maxwell, BRS964, of Musselburgh, Scotland. Mr. Clarke reported that he commenced his watch at 20.00 G.M.T. on Monday, February 6, after calibrating his receiver by locating WEL 8,950 kc. and ZSB 8,900 kc. At the exact hour the latter station closed down to listen for GEZAA, but G5FV could not receive the plane. His first success came at 22.00 G.M.T., when CQ de GEZAA was heard at QSA 3/1 R3/1/T8. Part of the message was copied, but QSB and QSC were bad. At midnight and at 02.00 G.M.T. signals were again logged, but little copied. The 04.00 G.M.T. transmission was not heard, but the next at 06.00 was copied almost completely. No further signals were heard in spite of a continuous watch.

Mr. Clarke used a 4-valve receiver and commented on the fact that the signals were exceptionally sharp, and unless the exact point had been found on the condenser dial it would have been impossible to locate them. The speed used was about 8 w.p.m.

Mr. Maxwell reported that he heard a transmission at 19.57 G.M.T. on February 6 and copied the message completely at R5/3. He also logged the full text of the 22.00 and 24.00 G.M.T. reports, but heard no more until 22.05 G.M.T. on February 7, when signals were just audible at R2/1. His last report covered the 00.02 G.M.T. transmission on February 8, when part of the message was received. We feel that a word of congratulation is due to these two members for their excellent efforts.

Early in the morning of February 7, the S.A.R.R.L. network picked up the plane, and it is to their lasting credit that no further transmissions were missed. We have unfortunately not yet received the full

report from ZU6W, but a message of grateful thanks has been sent to the S.A.R.R.L. from the Air Ministry *via* G5ML and ZU6W. We have made application to the Air Ministry for details of the equipment used, but this has not yet been made available.

* * *

In connection with the Mount Everest Expedition which is being led by Mr. Hugh Rutledge, we have pleasure in reproducing a photograph of the Camp 3 equipment, which was modified at very short notice by two of our members, Messrs. Loomes (G6RL) and Read (G6US). This comprised a portable transmitter built up from a redesigned W.D. Trench set, working with a maximum input of 15 watts on 60 to 120 metres.



This equipment will be used at a height of 21,000 ft. above sea level.

As mentioned in our last issue we were asked by the R.G.S. to obtain information regarding radio conditions from our B.E.R.U. members in India, but unfortunately we have not been given any advice as to whether amateur co-operation is required.

The Base Camp equipment is, we believe, at present installed at Darjeeling, and a smaller station has been erected at Camp 1, but to date no details of the frequencies to be used have come to hand.

Our members are, however, requested to listen for signals from the Expedition, and report to HQS any matters of interest.

We again thank all those who so readily offered help, and assure them that their offers were handed over to the authorities interested.

APPARATUS TESTED AND REVIEWED.

(Continued from page 291).

joint is made and may be relied upon to give good contact. Each socket is slotted and a valve fitted with the solid pins now in common use is held exceptionally tight. Two holes are provided in the ring for fixing screws, and four small feet allow the holder to be mounted clear of the baseboard.

Although comparatively new as an insulator, Beatl has a very high resistance. No breakdown of the insulator between the anode and filament pins took place when subjected to a strain of over 5,000 volts at a frequency of 7,000 kc., which voltage is not likely to be reached with standard 4-pin valves of the type used with such a holder.

CALIBRATION SECTION.

MESSRS. GAMBRELL BROS., LTD., have produced, at a reasonable price, a vernier dial and straight-line capacity condenser for use in amateur frequency meters and monitors. The dial, which will fit any variable condenser with a $\frac{1}{4}$ -inch spindle, can be obtained in a variety of patterns of 4-inch or 6-inch diameter, according to requirements. It is the first product of this type which has been placed upon the market in this country and is, of course, entirely British made. As might be expected from a firm of such experience, who are daily engaged upon the manufacture of frequency meters and instruments for Government service, this dial will adequately meet all the requirements of the British transmitter and experimenter.

The scale of the 6-inch dial is engraved 0-180° on lacquered nickel silver, and is similar in appearance to the dial on the Society's frequency meter, and may be precisely read to 1/10th of a degree. The addition of a 55-1 vernier drive renders a long handle unnecessary, although this may be alternatively fitted. In some types of frequency meters, where hand capacity is unavoidable, the long handle will be a useful asset. The 6-inch dial, fitted with removable extension handle, may be purchased for 18s., and, in our opinion, is well worth this moderate price. The extension handle is held in position by two pins, and is swivel-mounted on the 2-inch knob and may be removed in an instant.

The 55-1 vernier drive is constructed to be practically everlasting, and automatically takes up any slight wear that may occur. The dial and vernier drive may be purchased for 36s., which is a little less than a similar article which is obtainable from abroad.

The variable condenser is similar to the one used in the Society's frequency meter, but of slightly simpler and cheaper construction. It is of straight-line capacity law and total capacity of 0.00025 m.f. Used with a 0.0003 fixed capacity across it, it will give straight-line frequency "curve," and completely cover the 1,700-2,000 kc. amateur band, and thus giving harmonic relationship with all the other bands. The price of this condenser is 24s.

The whole assembly, vernier drive, dial and

condenser, mounted on an aluminium plate, 6 in. by 5 in. by $\frac{1}{2}$ in., and ready for screwing into a frequency meter cabinet, may be purchased at an inclusive price of £3. We have had the opportunity of examining the complete assembly, and, in view of the fact that it costs the same to buy dial and condenser separately, we would strongly advise prospective purchasers to have the complete assembly and be free from a certain amount of constructional labour.

There were two or three printer's errors in last month's BULLETIN. The last paragraph should read, "frequency drifts of 0.03 per cent. on several occasions." G5PL's frequency is 7,140, not 7,150 kcs. Attention is drawn to the fact that owing to another printer's error, G5YH's frequency was given as G6YH's in the January issue of the BULLETIN. The latter's frequency is given in the present issue.

Next month we will deal with "Choice of Fixed Condensers for Frequency Meters." Whilst it is not necessary to include standard type of fixed condensers for any but laboratory frequency meters, any old bundle of mica and foil loosely tied together will be obviously fatal to stability. With a well-known type of foreign fixed condenser that we tested, the temperature co-efficient was such as to cause a change of 0.1 per cent. in frequency over a range of 10°C.

The following frequencies were measured between January 22 and February 19 inclusive:—

G5NP	3525.4	G6IZ	7150
G5RV	3589.5	G6LI	7045
G5VB	3575.5	G6NF	7040
G6WY	3724.5	G6US	7156
G2XA	7180	G6YH	7047
G2GS	7113	RPK	7224
G2IG	7171	RTZ	7273
G2NU	7171	ZL4AI	14036
G2XO	7079	G2CX	14139
G5BJ	7048	G5IS	14302
G5ML	7182	G6GZ	14250
G15QX	7147	G6HP	14258
G5YY	7072	G6LL	14353
G6CL	7149	G6WY	14027
G6FN	7125	G6NF	14364
G6HP	7129		

A. D. G.

APPARATUS TESTED AND REVIEWED.

Non-corrosive Spade Terminals.

The makers of CLIX plugs, sockets, etc., have just added to their range of products a new type of non-corrosive spade terminal. Two models are available, a large selling at 2d. and a small selling at 1½d. These incorporate a new scheme for fixing the wire, which will ensure a much firmer and better metal-to-metal contact. Further, a collar is provided to prevent acid creeping up the spade portion and corroding the wire at the point of fixing.

As in their previous models, the cut-away part of the spade allows firm fixing to be obtained with either large or small screw terminals on the tops of accumulators.

The anti-corrosive plating appeared to resist the action of acid very well when tested on a corroded accumulator terminal.

* * *

A New Valve Holder.

A new low loss valve holder has just appeared on the market manufactured by K-P Instruments. Made in both four and five-socket types (selling at 1s. 3d. and 1s. 6d. respectively), the holder consists of a ring of white Beatl on which are fixed the brackets holding the sockets. The latter are screwed to the brackets, but by applying a hydraulic press to the securing screws an absolutely rigid

(Continued on previous page.)

A NOVEL POWER AMPLIFIER SYSTEM.

By C. J. PADDON, A.I.R.E.

THE self-neutralised, self-rectifying power amplifier is a commercial application that has not come greatly to the attention of the amateur. It deserves recognition, because it saves considerable expense—particularly in the high-power set.

There are two valves in the amplifier (the same type, of course, and preferably matched to a certain extent), with anodes parallel fed and con-

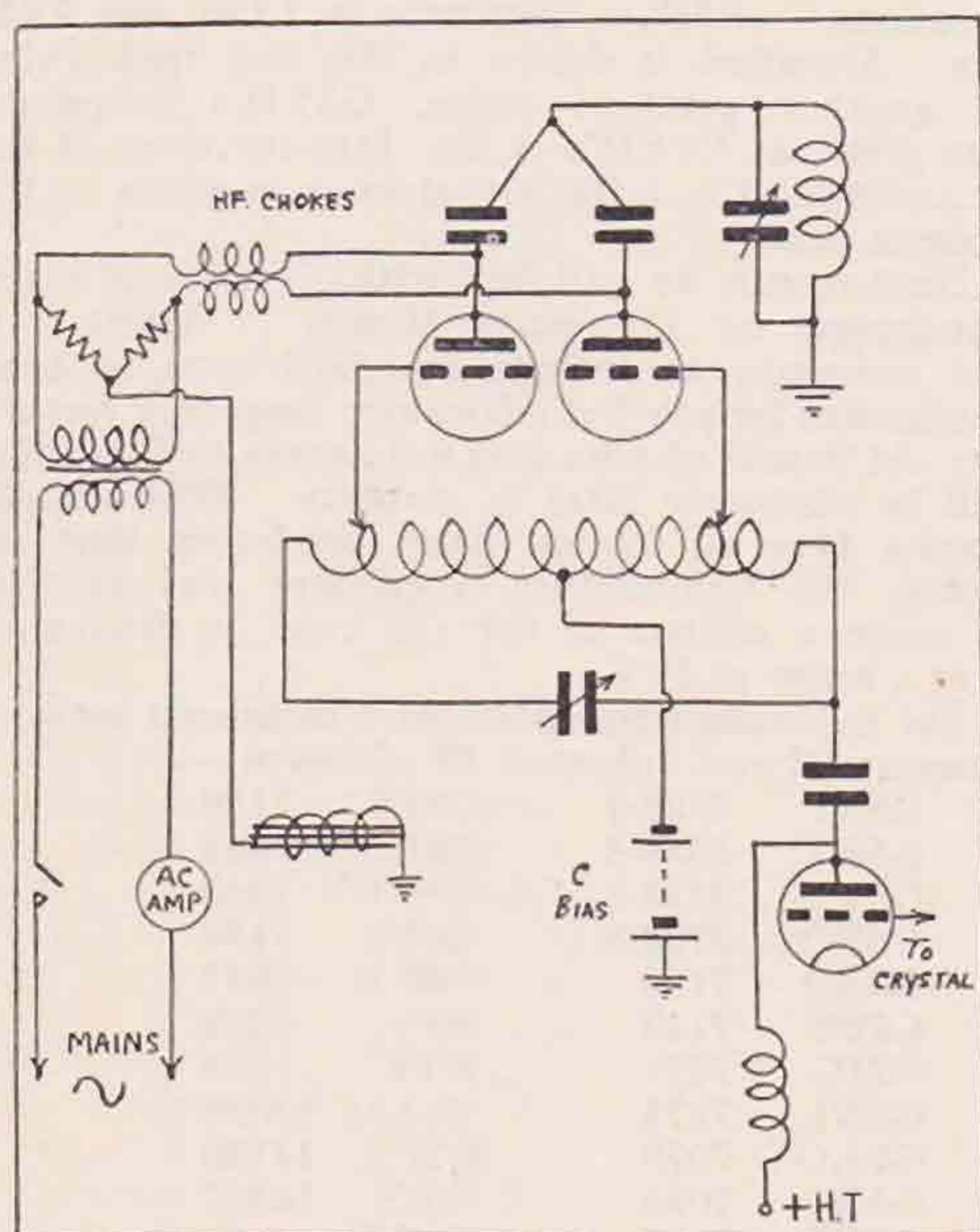

nected together through C_2 and C_3 (see figure) to the tank circuit. The grids are fed push-pull from a crystal oscillator (followed by optional frequency doublers) supplied from a D.C. H.T.

source. The method of applying excitation is unimportant so long as it is push-pull.

Raw A.C. is fed to the anodes from the high voltage secondary of a transformer, through the necessary H.F. chokes. It is advisable, though not essential, to use high resistance "bleeders" as shown, and the centre tap of the secondary winding is earthed through an L.F. choke. Keying is carried out in the primary circuit of this transformer and, since there is no filter lag, leaves nothing to be desired. In place of an anode milliammeter we use an A.C. ammeter of suitable scale in series with the transformer primary. This is as good, if not better, than a milliammeter, and the slightest variation in the load of the P.A. is very apparent.

One can picture the horror in the eyes of the conservative at the idea of a self-rectified circuit—and such horror would be more than justified if this were a self-excited set. The crystal drive, however, makes self-rectification permissible. An oscillograph of the signal side-band would show that the rough peaks produced by self-rectification are smoothed down by the crystal excitation; the resulting signal is very near D.C., with only a slight and rather pleasing tone, the frequency of which is twice that of the mains.

There are two important points to watch. First, the transformer must give equal voltages either side of the centre tap; and, second, the R.F. chokes must be good.

The following tip may be useful for S.W. choke construction. To build a choke for a given wavelength, cut a piece of suitable wire to a length of one-quarter of the wavelength in question, i.e., to work at 80 metres we measure off 20 metres of wire. This is close wound on a former $\frac{1}{2}$ in. to 1 in. diameter, and the choke is made.

(EDITORIAL NOTE.—The system of working two valves as a final amplifier with their grids driven push-pull, but with their anodes tied, as shown above, is supposed to work well as a frequency doubler, the anode circuit being tuned to twice the frequency of the drive.)

Strays.

G5SY states he W.A.C.'d in 3 hours 15 mins. on February 18, working the following stations on 14 mc. between 08.40 and 11.55 G.M.T. in the order given: AUIDE, ZL2JE, PY1IF, SU1EC, OH3NP and WIDHE.

Madame Schoote, F8YL, complains that her call is being pirated on 3.5 mcs. by a telephony station. She does not use "fone" and therefore warns G stations against replying to calls from the unlicensed station.

XOH5HB, who was recently in England, asks for reports on his telephony transmissions on 84.7 metres.

Owing to a printer's error Mr. Philpot's (G5PL) frequency was given in the last issue under Calibration Section notes as 7,150 kc. instead of 7,140 kc.

* * *

We regret to announce the death of Mr. Stanley Lawton, BRS962, who passed away early in January.

* * *

FIRST PRINCIPLES OF TELEVISION.

In Messrs. Chapman & Hall's announcement in our February issue, the price of the above book was inadvertently omitted. We should like to point out that this price is 12s. 6d. net.

GRID MODULATION.

By J. W. RIDDIOUGH (G5SZ).

HAVING recently completed a QRO C.W. transmitter for the 14-7 and 3.5 mc. bands, and wishing to carry out some experiments in telephony on the 3.5 mc. band with the German station D4UAK and the Austrian station UOICM, I was faced with the problem of modulating the output of the final P.A. valve. Choke control of the P.A. was ruled out on account of the additional gear and expense which would have been involved.

Modulating the buffer or sub-amplifier by choke control was tried, with disappointing results, not more than about 20 per cent. modulation being

A Ferranti 1 to 1 output transformer was put in, with the primary connected to the speech amplifier and the secondary in series with the grid leak and grid bias. This gave excellent results on speech but musical frequencies were very poor and distorted, so an old L.F. transformer with the primary and secondary in series was then inserted in series with the 1-1 transformer secondary and grid bias negative, the top side being by-passed to H.T., by a 0-1 mfd. condenser; the results were excellent on both speech and music.

Fully 100 per cent. modulation can be obtained by reducing the excitation from the buffer stage by moving the tapping down from the plate end of the buffer plate coil—in fact an adjustment can be found where the aerial current will double when a prolonged "Hello" is spoken into the microphone, but in this condition the carrier is broken—by careful tests and adjustment of the tappings, and also the tuning of the buffer tank coil, a position can be found where 100 per cent. modulation can be obtained without breaking the carrier.

A series of careful tests have been carried out with UOICM at Vienna, who reports that it is the best phone ever heard on the 80-metre band and received at R9 plus on a loud-speaker; D4UAK at Amberg, near Nuremberg, with whom tests have also been carried out, gives exactly the same report, which has since been confirmed by stations in Holland, Denmark, France, Germany and Spain; in fact most reports state "FB 100 per cent. modulation."

The diagram will fully explain the system used and may be of some use to other QRO stations who are faced with the difficulty of satisfactorily modulating a large power amplifier.

In conclusion, it should be noted that for efficiently modulating up to 200 watts, the speech amplifier should be capable of giving an undistorted output up to about 5 watts.

Strays.

BRS958, Mr. R. T. Ward, of 3, Highfield, Exmouth, Devon, will be pleased to furnish reports on 1.7, 3.5 and 7 mcs. 'phone transmissions.

* * *

Mr. Crawley, G5NP, claims first British 14 mc. QSO with Mauritius on November 14, 1932, when he worked V1MA. Any challengers?

* * *

Mr. Frank E. Lyons advises us that his office address is 12, Port Royal Street, Kingston, Jamaica, and his home address "Imimar," West King's House Road, St. Andrews, Jamaica, and not 68½, King Street, as published in our January issue.

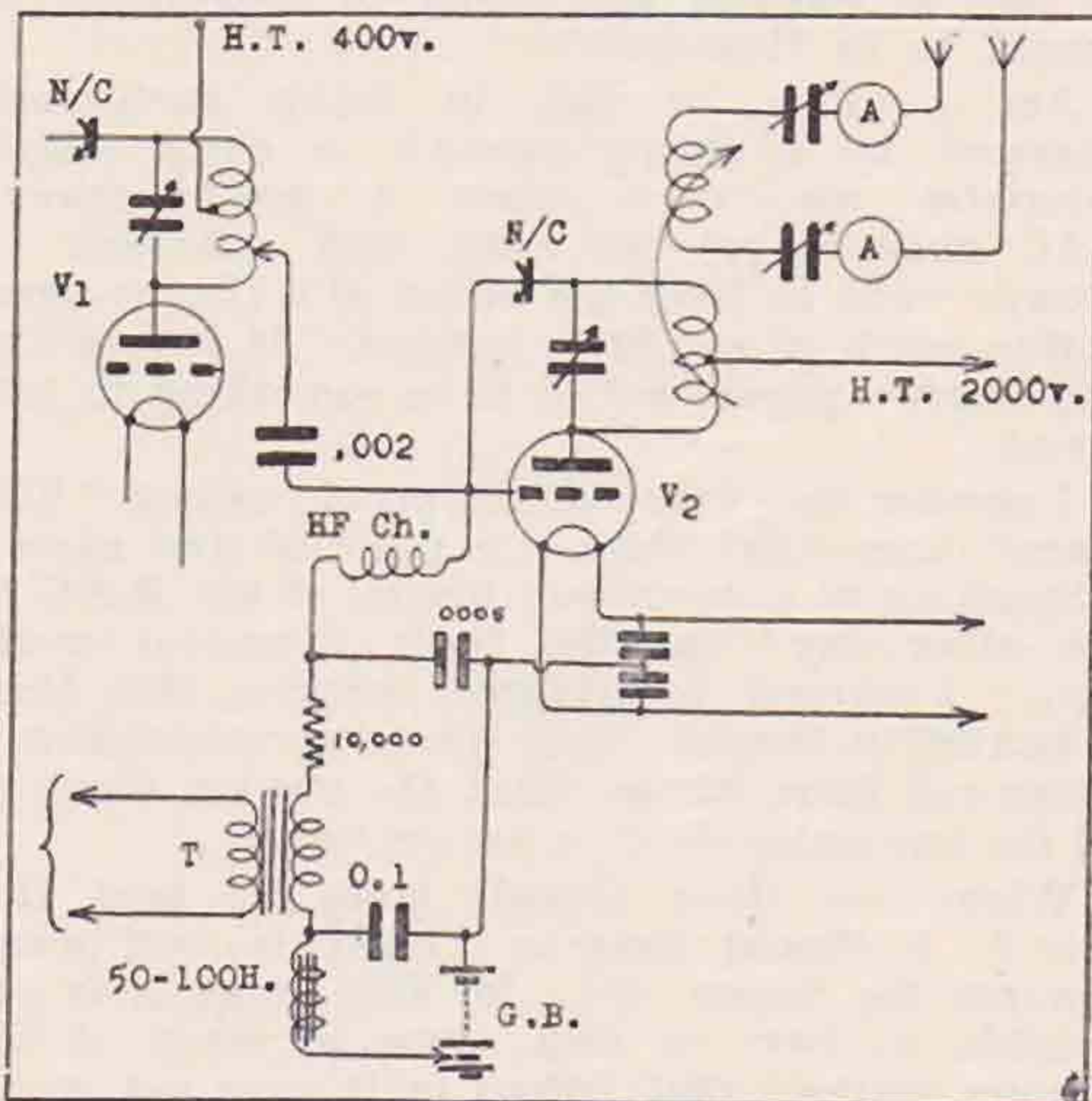

The above circuit shows the connections for the modulating system described in the accompanying article. V1 is a Mullard D.O.-24 working as a buffer amplifier. V2 is the power amplifier, a Mullard S.W.2. The output from the speech amplifier is fed to the 1-1 transformer, T. Note the additional high impedance choke between this transformer and the grid bias negative connection.

obtained; in fact, the results were not as good as when using choke control to the buffer stage as the final amplifier with an input of only 22 watts.

The suggestion of modulating the output of the 200 watt amplifier by choke control of the buffer stage was ruled out as being impracticable, and it was decided to try grid control on the final amplifier.

In the early days at Morecambe the writer was successful in obtaining excellent modulation on 200 watts with grid control to a self-excited transmitter, so it seemed reasonable to assume that with a properly neutralised C.C. transmitter and a high quality speech amplifier, that it should be possible to obtain good quality fone, as there would be very little, if any, frequency change as with a self-excited oscillator.

THE MONTH ON THE AIR.

BY UNCLE TOM.

(The wise old owl adjusts his horn-rimmed spectacles and delivers words of great sagacity upon the insertion of a coin in the slot.)

"THE Month on the Air"—and WHAT a month! This is written after three week-ends of the great dog-fight, during which I have acquired a greater command than ever of the English language—at least, that part of it that appears not in the dictionaries.

Who is there that dares to say, after "BERU-ing" 7 mc., that the general standard of European operating has improved? Was there ever such a conglomeration of unpleasant and insanitary sounds before radio was thought of? And, thirdly, what are we going to do about it? Short of sticking straws in one's hair and calling "CQ" with 100 kW. of spark, I can't think of a satisfactory solution.

Some queries about the tests come to mind. (1) Which particular law governs the probability of finding the weak station you have just called completely immersed in a vat of frying sausages when you change over for him? (2) How long has the U.S.A. been in the British Empire? (3) Why is a man always calling test when he is QSA 5 and signing when QRM has washed him out? (4) What is the percentage of stations equipped with *receivers* (real ones)? and (5) Why do people go on calling DX stations long after they have replied to someone else who had sufficient brains to give a shorter call?

Behind all this vitriolic comment there lurks a serious suspicion that some hams can still improve their tactics *quite* a lot; and the sooner they do it, the better it will be for themselves as well as thier brother-hams.

For all the grouses, I must say that this BERU Test business is great fun; but it certainly does take it out of one, especially the 7 mc. part of it. I noticed this year, as well as last, that "Test" calls were very unprofitable. It was a much better plan to wait until all the gang were firmly settled calling "Test," and then to snaffle a DX station that had been CQ-ing at the same time. Very artful, that.

Another dodge was to wait until two BERU stations were calling together, and to hang on to the weak one. Then, while all the gang with doubtful receivers were calling the stronger one, the weak one could be picked up cheap.

As a matter of cold fact, out of my thirty or forty contacts last year, only *one* was made with a test call. A Belgian ham in the very, very old days used to circulate a card worded as follows:—

"There was an owl lived in an oak;
The more he saw, the less he spoke;
The less he spoke, the more he heard—
Hams please copy that wise old bird."

And, by gosh, some of them might well do it. The number of them that were busy calling test (mostly much too fast), while two or three DX stations were calling their hearts out, was amazing.

Conditions, on the whole, were very, very good. Anyone who tells you they were bad is only trying to excuse a rotten receiver and/or transmitter.

Everything that could reasonably be expected to be on the air at any given time was there. (This only applies to Great Britain, naturally.)

7 mc. seems to have been productive of more contacts than 14, particularly in the high-power contest, where the Aussies and Zedders were too numerous to count in the evenings. But, once more, those Europeans!! What *are* they all trying to do? If some of them would spend a little time on an artificial aerial learning how to cure a chirp and how to modulate a carrier-wave—as well as learning the theory of smoothing—we should be in Heaven.

Am I alone, or not, in being *particularly* annoyed by a chirpy signal? A chirp simply infuriates me, even when a not-too-smooth RAC noise leaves me calm and collected. I always want to have the owner of a chirpy signal within reach of my little hatchet. If I once did, the Sunday papers would have something to talk about.

I wonder how many of the people calling "Test Beru," knew that there *is* a place of that name? "Speaking to a prominent official of the R.S.G.B. the other day" (as the *Daily What-is-it* would say), "I learned, to my great surprise, that Beru is located in Borneo. Our special correspondent is going out there to see what the natives think of all the free publicity they are getting."

Where are those awards going to land this year? I should imagine ZL4AI is well away towards the Senior one; for the Junior it is impossible to form an idea, since so many of the Empire stations that helped in it were not really taking part. They came on full power just to help the G's get their points. What a queue there was for ZL4BT in the mornings on 7 mc.! And who said that 25 watts was no good? Several 25-watt London stations knocked up 60 points or more in the first week-end of the Junior Contest, and things did admittedly fall a bit flat on the Sunday evening.

If everyone in the world were compelled to use a maximum of 25 watts, I think we should all get on just as well as we do now (except for the Russian commercials).

It would certainly be good practice for some of the unreadables, unspeakables and untouchables on 7 mc. Brrrr! May they all burn themselves out.

I was sorry that I made the rather caustic reference to the R.A.F. flight in last month's notes, when they went ahead and put up such a fine show. But they certainly *did* keep us waiting a long time for it. Anyway, they have done it, and all honour to the pilots, the machine, the R.A.F. organisation, etc., etc. Let's all sing like the birdies sing, etc.

If this BULL. reaches you punctually—Britishers, at any rate—you will be right in the middle of the A.R.R.L. Tests. Not many thousand miles from Croydon there will be "scenes of unparalleled activity" (journalese again). But a certain

R.S.G.B. member in London has arranged to be at home every afternoon during the said tests, and makes so bold as to hope that he is going to cause things to happen. Watch them!

My Cheshire correspondent calls my attention to the fact that he doesn't know of one Goyder-lock station in his district, where the neutered (?) P.A. is all the rage. On the other hand, a certain Manchester ham is heard using a 7 mc. crystal and feeding the antenna from the following doubler, and gets "T7 chirpy" reports. Is it the method of keying, or does the crystal want a bath?

He also says that the Lancs C.R. is annoyed about not being able to hear any VK's while other people are working them both on 7 and 14 mc.

News from Devon includes the momentous item that G5SY's famous "chemmies" have at last been replaced by Westinghouse H.T.11's. A 56 mc. field-day has been arranged for Devon at Easter, and a 28 mc. "chain" is being started from G6RP via G5QA and G5SY to G2FN.

"Windomitis" is rife in that part of the world. Every station in No. 6 District uses a Windom now.

Will D.R.'s and C.R.'s who have any news suitable for this page please send it to me, c/o Headquarters, before the 20th of each month? Thank you.

Stray.

HAF3C (Ing. E. Holly, Kaposvár Palais Vidor, Hungary) will be pleased to get into touch with other philatelists, for the exchange of new and used postage stamps.

Reception Tests.

Details of the next Reception Test will be found below and new participants are referred to the February issue of the BULLETIN. Logs are now being sent in from Holland and France and make very interesting the comparison of the various bands. In the last tests the 28 and 56 mc. gave decided negative results from all quarters, while DX on 7 mc. was very prominent and on 14 mc. an improvement was noticed. All logs should be sent to T. A. St. Johnston, 28, Douglas Road, Chingford, E.4, by April 25, when they will be circulated as a Budget to all participants.

RECEPTION TEST. SERIES 16.			
Test Letter.	Date, 1933.	Period, G.M.T.	Band.
A	March 26	08.30-09.30	1.7
B	" 26	10.00-11.00	56
C	" 26	11.30-12.30	7
D	" 26	18.30-19.30	14
E	April 2	00.00-01.00	3.5
F	" 2	10.00-11.00	28
G	" 2	11.30-12.30	1.7
H	" 2	18.30-19.30	7
I	" 2	23.00-24.00	14
J	" 9	09.00-10.00	3.5
K	" 9	11.00-12.00	56
L	" 9	18.30-19.30	28
M	" 9	22.30-23.30	7
N	" 16	00.00-01.00	14
O	" 16	09.30-10.30	56
P	" 16	11.30-12.30	28
Q	" 16	18.30-19.30	3.5
R	" 16	22.30-23.30	1.7

The 1.7 mc. Transatlantic Tests.

Congratulations are due to Mr. Austin Forsyth (G6FO) on effecting the first low-power contact with the States on 1.7 mcs., and although it is too early yet to give full details of the test that has been conducted by Group 10A during the last ten days of February (with a view to effecting two-way communication across the Atlantic on 2 mc.), sufficient information is forthcoming to show that the effort has not been in vain.

As described in the Contact Bureau notes this month, Mr. Forsyth made contact with WIDBM on February 19, with the remarkably low-power of 9.7 watts. Further news now to hand from the U.S.A. reveals that this station was heard on February 22 by WICHV, W1BMW and WIDBM, all of whom were on watch during these tests.

G5WU, of Penarth, was invited by G6FO to participate in the test, being a reliable 2 mc. station, able to work most easily in a westerly direction. Not only did G5WU hear some of the Americans who were keeping the schedules, but on February 25 he almost managed to make contact. He heard what appeared to be WIDBM calling him at 0633. and 0700 G.M.T., following test calls, but exceptionally bad Q.R.N. completely spoilt the possibility of further work on the band.

Conditions were quite good at the beginning of the ten days' period, but gradually deteriorated, with an increase in static. It was noticeable, too, that the American participants weakened in strength.

R.S.G.B. NOTEPAPER.

MEMBERS CORRESPONDENCE

RADIO SOCIETY OF GREAT BRITAIN

HEADQUARTERS CORRESPONDENCE IS ISSUED ON BLUE HEADING.

Full quarto size at 2/6 per packet of 100 sheets.

- Call Sign Brooches - 2/6
- Enamelled Coat Badges of Emblem R.S.G.B. - 1/6
- B.E.R.U. - 1/-
- Rubber Stamps of Emblem - - - - 1/6
- K.C.—Metre Charts - -/8
- Car Plaques of Emblem 3/6

All the above are Post Free, but orders must be accompanied by a remittance.

The R.S.G.B. Sales Department
53, Victoria Street, London, S.W.1

CONTACT BUREAU NOTES.

BY H. C. PAGE (G6PA).

THE most important happening during the last month, so far as Contact Bureau is concerned, has been the successful contact between G6FO and W1DBM on the 1.7 mc. band. Perhaps it does not sound very much on paper, but I can assure you it was no chance contact. All the members of Group 10a have been running regular listening schedules with stations in the States, and this contact was only established after many attempts. I would like to take this opportunity of congratulating all concerned, and G6FO in particular, for an especially fine piece of work.

No doubt some particulars of the schedule will be of interest. G6FO has been running his schedule from 05.00 to 07.00 G.M.T. with quarter-hour listening and calling periods each way. He first heard W1DBM on Sunday, February 19, at 05.10 G.M.T. calling England, and originating a test message to G5UM, his power being 225 watts. It was not until 06.35 G.M.T. that W1DBM heard G6FO, and his signals were then QSA5 R 5-6 T9 at G6FO. He reported G6FO QSA 2 R2 T9 with very bad QRM from other W stations. Despite the bad QRM, however, W1DBM managed to get all G6FO's message, including the fact that G6FO had heard WIAPK and WIASH, and he remarked that he had heard no other G stations. The contact continued right up to 07.50, when it was daylight this end. After 07.00 G.M.T. trawler QRM became very bad this side, though G6FO was able to copy W1DBM through it. G6FO was using a push-pull T.P.-resonant grid transmitter, with a crystal across the grid coil, the frequency being 1791 kc. The valves are a pair of Mazda P650's with 230 volts from D.C. mains on the plates, the input being 9.7 watts.

The aerial system is a 7 mc. "Windom" with a 40 ft. feeder, the roof being about 55 feet from the ground. A 50-foot counterpoise is used, and is arranged symmetrically below the aerial, sloping down from the radio room—a height of 35 feet—to a wall twelve feet high. The aerial system is direct-coupled to the plate coil of the transmitter, and aerial current is .52 of an ampere.

The receiver used was a tuned RF SG detector and pentode output. A short outside aerial about 40 feet long was in use at the time.

28 M.C. Group.

G6VP, Manager.

The B.E.R.U. Tests have naturally taken first place this month, and it was not to be expected that anyone would have been sufficiently optimistic as to try 28 mc.'s with the view of scoring points. There is, however, news. G5QA, a new member of Group 1B, has heard W8DYY on February 2, and the reception has been confirmed. He is to be heartily congratulated. Seemingly 28 mc is again coming to the fore in the States, and from BRS25 comes the news that 2BHK is in touch with the American 7th District and they desire our co-operation. They suggest that we send them a list

of our stations who would guarantee to be on the band during the spring and summer, each Sunday. In their turn, they guarantee to be transmitting at the same time.

As the movement originates from BRS25's Group, he will take control, so kindly send in your names to him.

The Group reports are, with two exceptions, nil.

Group 2b.—G5SY has been listening, but without result. G5QA has heard W8DDY on February 2, 1933.

Group 1f.—BRS25 has been improving his receiver but no signals have been heard. G20I has built a new receiver—S.G. Det. Pentode. The transmitter is a driven push-pull P.A. His signals have been heard in Liverpool. He is applying for higher power on 28 mc.

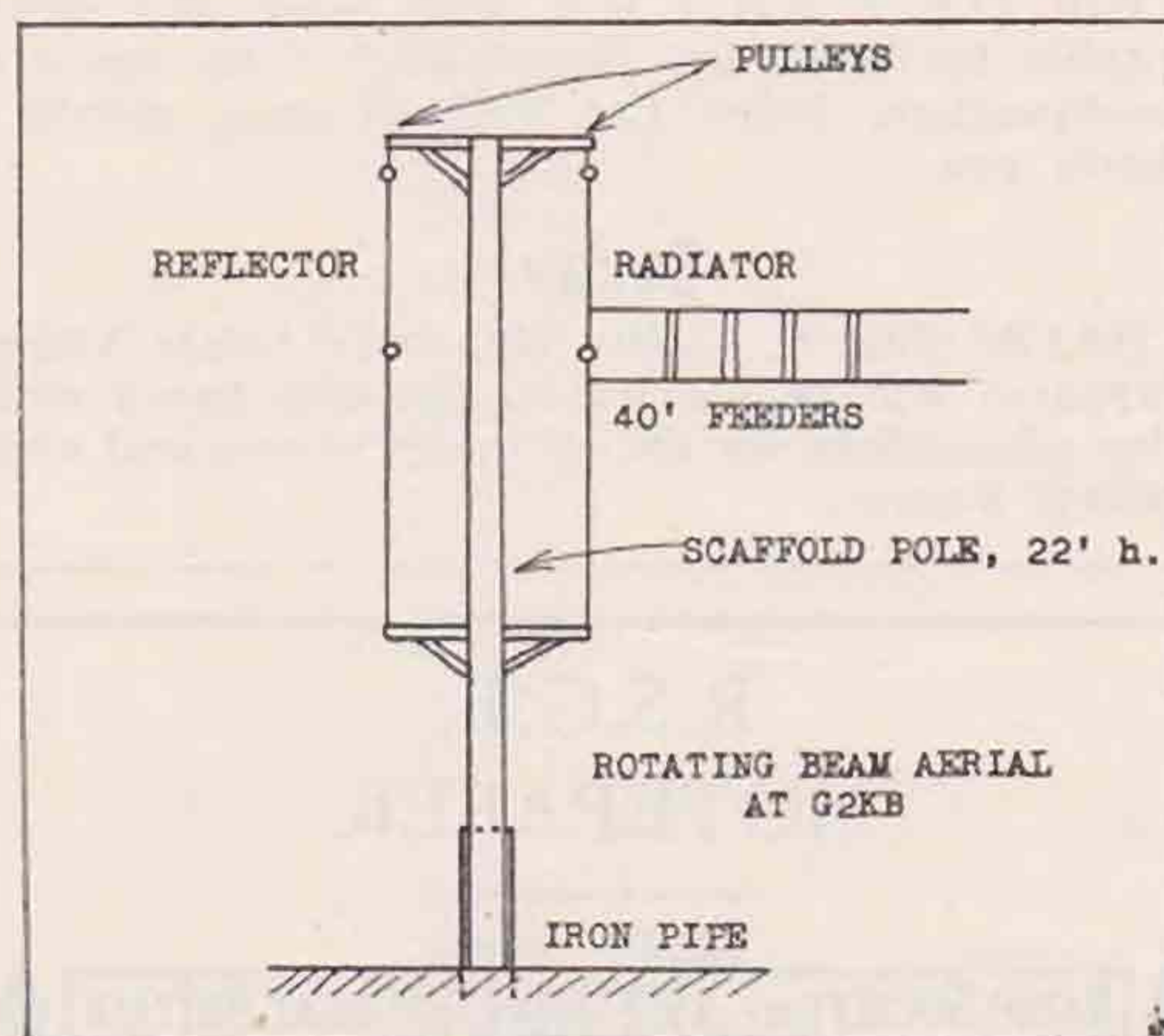

Fading, Blindspotting and Skip Group.

G6MB, Manager.

The fading groups are now on definite experimental work, and as this consists principally of collecting data, it is difficult to give any notes of findings. These experiments must necessarily be conducted over a lengthy period and it is unwise to indulge in speculation on short period observations. Measures are being taken to prevent overlapping of work more than is necessary, and so far as is practicable each Group has its own line of investigation.

To those amateurs who have applied for admission to Groups, I must apologise, and say that at the moment there are no vacancies in existing groups and there are not enough applicants to form an additional group.

Group 2a.—The notes in the January BULLETIN are very tentative, and considerable time must elapse before confirmation or otherwise can be expected. As these investigations deal with distances up to 1500 miles only, another line of experiment is being pursued on DX transmissions.

Group 2c is discussing sunspots and the Heaviside

Layer, and their effects on 7 mc. signals, and although sufficient time has not elapsed to get definite results, good progress is being made.

Group 2d is studying the effects of lunar phases on short wave reception of DX signals, and also the fading of the ground wave. In the case of the latter, they suggest that topographical features may be the predominant factor, but opinion is divided.

Ultra High Frequency Group.

G6XN, Manager.

Some interesting work has been done this month by G2KB. He has definitely decided a disputed point—are trees effective as screens? Walking with a receiver along a road about a mile from the transmitter, with a row of trees intervening, reception was very poor behind each tree, but between each it was louder in the ratio of R6 to R3! The effect was more marked when the trees were wet. Other tests showed a complete fade-out under a railway bridge and confirmed the "shadow" effect of hills. He sends an interesting sketch of his special 5-metre aerial. Not only beam aeriels, but any type of horizontal or vertical dipole may be put up in a few minutes.

2BHX is experimenting with receivers, but complains of absence of signals on which to test them. He suggests that three or four London stations should take it in turns to transmit for a definite period every Sunday. This seems an excellent idea; and as a result of this suggestion, G6XN will be on 5.30 metres from 14.00-14.15, prevailing time, on the fourth Sunday in each month, starting in March. A substitute may be arranged.

Will at least three other stations please come forward?

In connection with beam aeriels, G2CZ reminds us of the possibilities of directors, in addition to reflectors, thus obtaining a sharper beam.

BRS77 is again active, after his move to Birmingham. He hopes to produce electron oscillations with a V.24 valve.

2 M.C. Group.

G5UM, Manager.

Ten watt Transatlantic communication on 1750 kc., so long a subject for idle speculation, is now an accomplished fact. It comes as the successful climax to continued efforts made by Group 10a to span the Atlantic on 2 mc. At 06.30 G.M.T. on February 19, W1DBM, an R.S.G.B. member living at North Falmouth, Mass., effected contact with G6FO, of Newport, and remained in touch for about an hour, the American with 200 watts on 1755 kc., and G6FO with 10 watts input on 1791 kc.

Following the Group 10a Transatlantic reception test on 2 mc. last December, a further test was organised for the last ten days of February, and proved overwhelmingly successful on its first day with G6FO's remarkable QSO. Two other Americans were also coming across on February 19, namely, W1APK and W2ASH (?), the former, with 200 watts, at QSA5.

W1DBM reported G6FO as QSA2 R2, his receiver being a 3-stage set with a r.f. pentode preceding the S.G. detector.

Two months ago one wrote "Clearly, a power of 10 watts is far too low for Transatlantic communication on 2 mc." One now wishes to qualify this statement with "Unless the ten watts are used with the utmost efficiency!"

Unfortunately, these notes must be dispatched to the C.B. Manager before the present series of Group 10a tests is more than a day old. It is hoped, however, to record any further noteworthy developments elsewhere in the BULLETIN this month.

Meanwhile, one feels that G6FO's feat of opening up Transatlantic communication on 170 metres after ten years (one does not recall any QSO's since the old 1923 tests) is deserving of very high commendation.

Antenna Group.

G2OP, Manager.

Conditions on the higher frequencies have for some time been so unstable and unreliable that it has been impossible to do any comparative tests with aeriels, but I have received several reports of interest recently. ZD2A writes that just before the B.E.R.U. tests he tried out the G2BI aerial, which has already appeared in these notes, with the result that in two evenings he had 12 QSO's with a distance of 46,000 miles to his credit, using a power of about 25 watts. He goes on to say, "the next two evenings were also similar. Now I have only to call test once, and after that I am busy competing with the stations I hear calling me every time I sign off. Beforehand I used to consider it good going to get about three QSO's an evening. Now it seems that I can get as many as I like to go on for." The tests are not over at the moment of writing, but judging from what I have heard, ZD2A should put up a good show, as I seem to have heard him at all hours of the day. It is also interesting to note that SU1EC is also using this type of aerial, which he says is superior to his old Zepp, and he, too, comes in here at all hours very consistently and strong.

G6ND has been experimenting with a Zepp and finds that the usual 66 and 67 ft. varieties are too short. He also gets better results with parallel tuning than with series. G2YU has still been getting out remarkably well with the Wilkinson aerial. G5FI has been using an A.O.G. on 1.7 mc. I await further details of it. G6GV has sent cards to members of the group for their reports, which I hope they will send in to him monthly. There are some vacancies in the group and anyone interested should write G6GV. I hope that all those who took part in the B.E.R.U. tests will send in reports to G2OP on their results and observations, as during these tests they should be able to get directional effects noted and also many other points suitable for recording. They should, of course, give a detailed account of the aeriels they used and the reason why they chose the particular type.

Strays.

VU2FY, Mr. O. A. F. Spindler, Coromandel P.O., S. India, will be carrying out a special series of tests on c.w. on the 13th, 14th and 15th of April, 1933, wave length 41.5 metres, 7,229 kc., at 5 a.m. Indian Standard Time, corresponding to 00.30 a.m. G.M.T. He will be grateful if all British amateurs will look out for him. Each test will last 15 minutes and all reports should be sent direct and will be acknowledged by special QSL card.

Mr. Tilse, VK4WO, of Avoca Street, Yeronga, Brisbane, will be pleased to exchange letters and photographs (views, places of interest, etc.) with members in any part of the world.

NOTES and NEWS



BRITISH ISLES

DISTRICT REPRESENTATIVES.

DISTRICT 1 (North-Western).

(Cumberland, Westmorland, Cheshire, Lancashire.)

MR. S. HIGSON (G2RV), "Hebblecroft," Egremont Promenade, Wallasey, Cheshire.

DISTRICT 2 (North-Eastern).

West Riding, Durham, Northumberland.)

MR. L. W. PARRY (G6PY), 13, Huddersfield Road, Barnsley, Yorks.

DISTRICT 3 (West Midlands).

(Warwick, Worcester, Staffordshire, Shropshire.)

MR. V. M. DESMOND (G5VM), 199, Russell Road, Moseley, Birmingham.

DISTRICT 4 (East Midlands).

(Derby, Leicester, Northants, Notts.)

MR. H. B. OLD (G2VQ), 3, St. Jude's Avenue, Mapperley, Nottingham.

DISTRICT 5 (Western).

(Hereford, Oxford, Wiltshire, Gloucester.)

CAPT. G. C. PRICE (G2OP), 2, St. Anne's Villas, Hewlett Road, Cheltenham, Glos.

DISTRICT 6 (South-Western).

(Cornwall, Devon, Dorset, Somerset.)

MR. H. A. BARTLETT (G5QA), "Donbar," Birchy Barton Road, Exeter, Devon.

DISTRICT 7 (Southern).

(Berkshire, Hampshire, Surrey.)

MR. E. A. DEDMAN (G2NH), 63a, Kingston Rd., New Malden, Surrey.

DISTRICT 8 (Eastern).

(Cambridge, Huntingdon, Norfolk, Suffolk.)

MR. S. TOWNSEND (G2CJ), 115, Earham Road, Norwich.

DISTRICT 9 (Home Counties).

(Bedfordshire, Hertfordshire, Essex, Buckinghamshire.)

MR. F. L. STOLLERY (G5QV), "Kingsmead," Lancaster Gardens East, Clacton-on-Sea, Essex.

DISTRICT 10 (South Wales and Monmouth).

(Monmouth, Glamorgan, Breconshire, Carmarthen, Cardigan, Pembroke.)

MR. A. J. E. FORSYTH (G6FO), "St. Aubyns," Gold Tops, Newport Mon.

DISTRICT 11 (North Wales).

(Anglesey, Carnarvon, Denbighshire, Flintshire, Merioneth, Montgomery, Radnorshire.)

MR. T. VAUGHAN WILLIAMS (G6IW), "Malincourt," Grosvenor Ave., Rhyl, Flintshire.

DISTRICT 12 (London North).

MR. S. BUCKINGHAM (G5QF), 19, Oakleigh Road, Whetstone, N.20.

DISTRICT 13 (London South).

MR. A. D. GAY (G6NF), 49, Thornlaw Road, West Norwood, S.E.27.

DISTRICT 14 (London East).

MR. T. A. ST. JOHNSTON (G6UT), 28, Douglas Road, Chingford, E.4.

DISTRICT 15 (London West and Middlesex).

MR. H. V. WILKINS (G6WN), 81, Studland Road, Hanwell, W.7.

DISTRICT 16 (South-Eastern).

(Kent and Sussex.)

MR. H. A. M. WHYTE (G6WY), Killiney, Worsley Bridge Road, Beckenham, Kent.

DISTRICT 17 (Mid-East).

(Rutland, Lincoln and E. Riding.)

MR. A. E. LIVESEY (G6LI), Stourton Hall, Horncastle, Lincs.

SCOTLAND.

MR. J. WYLLIE (G5YG), 31, Lubnaig Road, Newlands, Glasgow.

NORTHERN IRELAND.

MR. C. MORTON, (GI5MO), 27, Bristol Avenue, Belfast.

District Notes for publication should be written as concisely as possible and should be in the Editor's hands by the 25th of the month preceding publication. They should be of a general rather than personal nature. Individual reports from County Representatives will not be accepted for publication.

DISTRICT 1 (North-Western).

THE C.R. for Cheshire wishes me to ask all members of this district if they are interested in a Crystal Register, and, if so, will they please drop him a line stating the frequency of their crystals and he will keep the official record. The advantage is that anyone about to purchase a new crystal could be advised by him of unoccupied frequencies. Other news from Cheshire is very scarce. The only stations who report are G5CN, who is active with CW and 'phone in the 1.75 mc. band, and G2OA, who is rearranging his gear and also about to try 1.7 m.c. G2RV is also rearranging, and hopes to be on the air by the middle of March. G5OZ is active on 7 mc. and is the only other reporting station! It looks to me as though the rest of the Cheshire stations have hibernated for the winter. What about some reports?

Twelve stations in Lancashire report active, and they are all in Manchester. Not a single station from Liverpool or any other town reports to its C.R. The active stations are G6JN, 2WP, 2DH, 2WQ, 5WR, 5YD, 2OI, 6AX, 6ZS, 2DF, ex-2BRG, 6ZU, ex-BRS1037, and 2BMX.

It seems that Lancashire has lost Liverpool to

Cheshire. With the inauguration of the M.A.T.S., this state of affairs is likely to continue, and I expect that verbal reports will be the order of the day rather than written ones. Members that I meet in Liverpool two or three times a week just tell me that they did so-and-so, or worked so many W's, and expect me to put it all in these notes. It's all very well saying that you are active to me, but the C.R.s want to know what is going on in their own county, and it is up to you to write and tell them. I know of several people who are very active, such as G6OM, 6TT, 6CX, 6JT, and many others, but the C.R.s never hear from them. Why is it that the Lancashire report never contains anything but Manchester and district news? Then there are one or two stations in the two northern counties, yet I never hear a word from G2YN. Anyway, it's up to you. These notes will be as interesting as you care to make them. I am told that many of the trawlers working on the 1.7 mc. band sometimes use language that could hardly be called polite. I would ask those of you who may be questioned as to whether these are amateur stations or not, to make quite certain that the idea is dispelled beyond doubt.

I am glad to see that several stations have applied for high-power permits. We should have some good stations in this district soon.

DISTRICT 2 (North-Eastern).

Only one report has come to hand from Yorkshire, this month, and that from G6VR, who is active after a long illness. He would appreciate BRS reports. 2AJW applied for a full licence without success, but hopes to have more luck at his next attempt. He is anxious to obtain information covering the Goyder Lock system. G6PY was active throughout the B.E.R.U. Contests and hopes that other District 2 stations will have reported their results to HQs. Snow during the last week-end of the Junior caused leaks across feeder spreaders.

From the Middlesbrough area G6CV reports that

DISTRICT No. 1.

Conventionette LIVERPOOL, APRIL 9th

Full particulars from Mr. Higson, G2RV, or
County Representatives.

The following stations are active:—G5QU, 2AVM, BRS922, BRS1016, although no reports are to hand. G5XT is experimenting with the Wilkinson aerial and very good results have been obtained. G5CU is active on 7 and 14 mc. and is now testing a CO.FD.PA. against his former push-pull TP.TG. on 14 mc. G6CV has been rebuilding his receiver.

Meetings are held in the Royal Hotel, Middlesbrough, once a fortnight, when visitors will be welcome. It was agreed at the last meeting to build a TX and RX for the use of members.

May I again appeal to all members in the district to send me a postcard each month outlining their activities?

An enjoyable evening was spent by twenty members of the Leeds and Sheffield districts on March 4, at the Angel Hotel, Sheffield.

The following were present: G2AS, 2BH, 2RU, 2XH, 2VQ, 5HK, 5TQ, 5NP, 6BX, 6KU, 6NP, 6WJ, 6UF, 6LF, 6OM, 6PY, 2AJO, BRS843, and 1067.

It was regrettable that no one from Leeds itself arrived, although the meeting was held at the request of the Leeds group.

Matters in connection with commercial interference, local piracy, and police radio were discussed at length. The local G.P.O. inspector was a welcomed visitor at this meeting.

DISTRICT 3 (West Midlands).

Our district conventionette is to be held on Sunday, March 19, at the Hope and Anchor Hotel, Edmund Street, Birmingham. The arrangements are as stated in the February issue, except that luncheon will be at 1.30 p.m., so that the arrangements are as follows: Assemble at 12.15 p.m.; luncheon, 1.30 p.m., business meeting to be followed by tea at 4.30 p.m. Please advise me at once if you are coming, so that I can complete the arrangements.

Reports have been received from G5ML, 6KI,

6ML and BRS46; G6KI is now W.B.E. and only requires South America for W.A.C. G5ML finds 25 watts almost as good as QRO.

DISTRICT 4 (East-Midlands).

Mr. Storer reports direct to H.Q. that Leicester is to have a Radio Society. Several active members of the R.S.G.B. are forming a society with the object of bringing together local amateur transmitters and those interested in the reception of amateur signals. By taking this step, they hope to increase the numbers of members in R.S.G.B. A meeting has been arranged for March 3, and further details will be given in the next number of the BULLETIN.

All members are active on one or more bands, with the exception of G5VH, who is rebuilding. G6GF and G6JQ are experimenting on 56 mc. and hope to join G2KB's proposed 56 mc. network. The following are active: G5VH, G6GF, G6WU, G6JQ, 2BHA, 2BVN, BRS683, 866, 884, and 1028.

DISTRICT 5 (Western).

There is little of general interest to report during the month except that the chief activity has been in connection with the B.E.R.U. tests. Two units of the R.N.W.A.R. have come to life, one in Bristol, under K. H. Arthur, and another in Gloucester, under J. W. Hamilton.

The usual monthly meeting was held at Bristol, and the Wilts. letter budget contains many attractive features.

The provisional arrangements for our District Conventionette are that it will be held at the Grand Hotel, Bristol, where lunch and tea will be served on Sunday, May 7. Please make a careful note of the date, and do not forget that the Midlands Conventionette will be held in Birmingham, on Sunday, March 19. These good friends of ours always support our Conventionette, and by their attendance last year made ours the biggest in the Provinces.

LONDON HAMFEST

A London Hamfest has been arranged to take place at Pinoli's Restaurant, 17, Wardour Street, on Wednesday, April 5. Dinner will be served at 7 p.m. Price 5s., payable on the night. Ordinary dress. Accommodation has been reserved for 50.

DISTRICT 6 (South-Western).

All members in the area are active, and all except three are contributors to the monthly budget, which still continues to be of immense interest and help. The annual conventionette (as mentioned before) takes place on Whit Sunday, when members will meet at the D.R.'s QRA at approximately 3 p.m. Further details will be given later, and it is hoped a good crowd will attend. The following stations are active in the district: G5SY, 5WY, 5QA, ZFN, 2ZP, 5YR, 6RP, 5VL, BRS836, 6KY, BRS958. The latter, now in Oxford, is hoping to get a three-letter call very soon. G5SY has at last pensioned off his chemi-rects, and has invested in a pair of Westinghouse H.T.11's, giving him a good

1,000 volts. He was WAC in 3½ hours on Sunday, February 19, and in 12 hours on Sunday, February 12. G5QA also was WAC on the 19th, but had to work a local ham for the European contact! PY signals have been coming in well on 14 mc. in the early mornings, free from W QRM. G5QA on February 1 heard W8DYY on 10 metres calling for a test. Time was 18.30 G.M.T., and his signals QSA4 R5. A 56 mc. field day is being arranged for the Easter vacation, and we hope for better luck than last time. G6RP, 5QS, and 5WY have been more or less rebuilding, the latter having now hooked his first VU.

DISTRICT 7 (Southern).

The chief activity in the district this month has naturally centred round the B.E.R.U. tests. G5LA, 2NH, 6GZ, 6NK, 2PF, and others have been heard in the senior contest, and some good scores have been attained, chiefly, of course, owing to the good conditions prevailing. A number of stations also took part in the low-power tests, and at least one of the high-power men was surprised at the results obtained on 25 watts with the QRO stations out of the way!

The February monthly meeting was unfortunately cancelled owing to illness at G2NH, and also owing to the fact that a number of the members themselves were recovering from 'flu.

This cancellation was unfortunate, as this is the first break in the continuity of the meetings since their commencement some years ago.

The April meeting will be held at G2NH' on April 2, at 14.30 G.M.T.

Television now seems to be quite a popular activity in the area, and provides much discussion in the letter budget.

BRS911 would like to hear from other BRS men in No. 7 District, with a view to co-operation in the occupancy tests.

The C.R.'s and D.R. would be glad to receive suggestions from the members for field days, as we want to arrange a programme in order to make these field days an even bigger success than those of last year.

The area will, of course, be supporting the national field day, and as this will be fully discussed at the April meeting, we would ask all who possibly can to attend and take part in the discussion.

The following reported active this month:— G2DC, 2YL, 2GG, 2NH, 5MA, 5RS, 5JZ, 2PF, 5LC, 6NK, 6GZ, 6GS, 5LA, 2PF, 2DZ, 6BU, 2AUA, BRS911, BRS1040.

DISTRICT 10 (South Wales and Monmouth).

This district is now more lively than ever before, thanks to the efforts of the C.R.s and the enthusiasm of active members.

A meeting at Newport on January 26 was attended by G5BI, G5NS, G5WU, G6FO, G6PF, and BRS907, who made a two-hour journey from Swansea to be present. Influenza prevented a larger attendance.

On February 6, G5WU, C.R. for Glamorgan, and the D.R. attended a most enjoyable meeting of the Swansea Short-Wave Club; many interesting points were raised in a discussion on amateur radio in general. This club, which has become affiliated to the Society, is run under the guidance of local R.S.G.B. members, and is fortunate in having Colonel C. L. Isaac, K.H.S., as President.

Another organisation which is also affiliated is the Blackwood Radio and Television Society. The D.R. attended an enthusiastic meeting of 30 members on February 13, when the work and objects of the R.S.G.B. were explained to a gathering which had not previously heard of amateur radio. The Society is to go in for short-wave transmission and reception as a result of this visit.

We welcome as new members Capt. R. T. H. Gelston, Royal Corps of Signals, of Cardiff, who will be on the air shortly, and Mr. R. H. Stevens (Newport), who will have had his BRS number allotted by the time this appears.

As regards general activities, the B.E.R.U. contest was well supported by both QRP, TX and RX members, though at the time of writing no definite information is to hand. The D.R. was able to secure some helpful Press publicity in connection with this. 2BRA (Newport) is now G6YJ, and is working on 1.75, 7 and 14 mc. with QRP. He reports a contact with TF on 7 mc. as his best DX so far. G2PA (Newport) was QSO ZD2A

DISTRICT No. 3.

Conventionette

BIRMINGHAM, MARCH 19th

Assemble at "Hope & Anchor" Hotel, Edmund Street, at 12.15 p.m. Luncheon 1.30 p.m. Followed by Business Meeting. Tea at 4.30 p.m.

with QRP on 14 mc., though, like the D.R., he has had a run of bad luck with his gear. A larger number of members are showing interest in the 1.75 mc. band, which is a matter of importance in this district owing to the distances between groups of members, making regular personal meetings difficult. BRS907, of Swansea, regularly receives daylight 'phone from both G5WU and G6FO, while the majority of transmitting members are on the band at week-ends for district contacts. G6FO was QSO the States on 1.75 mc. at 06.35 G.M.T. on February 19, when WIDBM, of North Falmouth, Mass., was worked for over an hour with an input of 9.7 watts to the standard 170-m. rig. His power was 225 watts, with an aerial 560 ft. long!! The QSO was difficult owing to bad QRM that side, but reports and other information were exchanged. This is believed to be the first W-G QSO on 1.75 mc. since the early 1-kw. days on 200 m., in 1923. The test was in connection with a joint effort by Group 10a, following our success in receiving American stations on 170 m. early in December. It shows the possibilities of the band for DX working. QSO has now been made with the States from G6FO on 14, 7, 3.5 and 1.75 mc. with an input never exceeding 15 watts. At the other end of the scale, I have recently had a report from the South of France reporting reception of 10-metre signals when, on December 18, a test was being carried out with Bristol with an input of 11 watts.

Finally, I should be glad if all members who

receive notices from the C.R.s would reply to them, as these questionnaires are issued with the idea of getting members' views on various points upon which I have to report to Council.

DISTRICT 11.

Council have pleasure in announcing that Mr. T. Vaughan Williams (G6IW), "Malincourt," Grosvenor Avenue, Rhyl, has been appointed acting D.R. for North Wales. It is hoped that the active members in that area will communicate with Mr. Williams.

DISTRICT 13 (London South).

The South London Transmitters' Society's annual dinner went off very successfully, with an attendance of over 30.

The senior section of the B.E.R.U. tests has now finished, and South London was well represented by G2CX, G2ZQ, G5AW, G5PL, G6HP, G6NF and G6QB and others. G2ZQ and G6HP managed to get over 500 points each, and it is hoped that at least one of the leading British stations may be found in this district.

The clean operation of stations employing Goyder-lock in this area was a tribute to the reliability of this system.

Activity on 56 mc. is at the moment dead in this district. There is so much to do on other bands that little time is available for these less populated frequencies.

G2ZQ is to be congratulated on heading the list of G stations in the recent Accuracy Contest organised by the Ragchewers' Club.

DISTRICT 14 (London, East).

At our last meeting held at Chingford it was decided to hold the next Field Day on March 25-26; the QRA will be at Rookwood Hall, Abbess Roding. With regard to the station in the Ilford district pirating the call-sign of G5QV, members of No. 14 District will certainly assist District 9 in ridding the latter District of their pest. G6FY recently gave a lecture on "Short Waves" before the Woodford, Wanstead and District Radio Society. A crystal register is being compiled for the District, and all stations are asked to send details to the D.R. The next District meeting will be held at 28, Douglas Road, Chingford, E.4, on Tuesday, March 21.

DISTRICT 15 (London West and Middlesex).

I was very sorry not to be present at our last area meeting, but it was necessary for me to attend a Council meeting that evening. I was, however, glad to hear that several new members were present.

The next meeting will be held at G6WN on Wednesday, March 22, at 7.30 p.m.

It is a great pity that my appeal for more members to support the letter budget seems to be in vain. This month only four reports have come to hand. I would advise all new members to contribute to this budget and so help one another with views on different matters that come up for discussion. If you are not certain what to do, please write to me at 81, Studland Road, W.7.

There is another very great advantage in getting the budget as I shall use it to notify members of various trips I propose running to the provincial conventionettes. These details are only secured at the last minute and the budget forms a convenient means of letting the membership in the area know the particulars.

G6VP sends a long letter and has been very busy with aerals again. He has made a fair score during B.E.R.U. tests. BRS642 has been busy with his receivers and again claims hearing telephony from the west coast of America, this time KNX on the broadcast band. Last month I made a mistake as the station heard on 3.5 mc. was W6DJZ and not W6DJC.

G6RS has now got his station G6IU at Walton going, and has also been testing telephony, using the Telefunken system. BRS955 has obtained his three-letter call (2BLX), and tells me that BRS957 will have his by the time this is in print. I understand 2BWG is awaiting his Morse test.

G6WN has been active during the B.E.R.U. tests, with very little success.

DISTRICT 16 (South-Eastern).

I have only had a report from Sussex this month.

G2PF and G2AO are active on DX work, G6SU is temporarily QRT, G2CC is now closed down for good, but wishes to be remembered to all his radio friends. G5JZ and G2AO are hoping shortly to have duplex television QSOs on the 1750 kc. band. G2AX and G5YA have both started experimenting with television.

G6WY, 2IG and 2MI were heard on during the B.E.R.U. contest. Please, G2IG, send a report in for next month.

DISTRICT 17 (Mid. Eastern)

We are pleased to report that G6OO has made a successful recovery from his unhappy accident, and that he is again fully active.

The following Yorkshire (East Riding) stations are active on most bands: G2QO, G2KO, G6OS, G6OY, G5VO, G6WD, G6OF, G2TK and G2KM.

G5FV recorded the signals of GEZAA, and, we believe, established a record for the country, since no other station appears to have achieved a similar feat. The station secured contact with the 6th district of the U.S.A., and with Japan on the 7 mc. band during the Senior B.E.R.U. tests. Both Q.S.O.'s are very unusual. B.R.S. 896 is learning code under the tuition of G5VO, whilst BRS 738 assists in the reception tests, and BRS 967 is active on 28 mc.

From Lincolnshire we have to record that G5GS has had the misfortune to be "*hors de combat*" on account of influenza, but we are glad to know that he is again working. His station would have contested in the B.E.R.U. contest, but he was obliged to attend the B.I.F. at the last moment, and so suffered a great disappointment. G5IX sends in a long and interesting report, and G6AK is joining the happy band of crystal users.

2BIH is well on the way to getting an open licence, whilst G5CY, 6HK, BRS426, BRS1021 are active.

G6LI contested in the Senior B.E.R.U. tests, obtaining very satisfactory results. During the tests two aerals were used, at right angles to each other, and changed by a switch, worked by ropes, and suspended at a height of 50 ft. in the air.

There are no reports to hand from Rutland.

We have several new members signing on in Lincolnshire who will be fully registered by next month.

The Annual Conventionette of the District will be held on April 30. Full details to be announced later by circular.

SCOTLAND.

The recent institution of the district officer circulars, which I understand they circulate among their members, leaves the writer rather short of "copy" for his BULLETIN notes (faint cheers from Mr. Editor, Hi!), but as there are some who possibly may not have the opportunity of seeing these circulars, attempt will continue to be made to give a concise resumé of the month's events in Scotland.

It gives me very great pleasure to record the success of G5ZX in the recent QRP contest. His final



The above photograph shows a group of the members of the Medway Amateur Transmitters' Society, with their transmitter G5MW. The Society draws its membership from fully-licensed transmitters, A.A. men, BRS stations, and BCL's; the latter are on the way to becoming fully-fledged amateurs at a later date. The Society has arranged a competition to take place this month, in connection with which the "Rochester and Gillingham Observer" has offered a cup as premier trophy. G2MI is the Hon. Secretary of the Society, and can be seen directly behind the transmitter, while G6NU, the President, is on his immediate left.

score was 272 points, which put him considerably ahead of the other contestants and insured the arrival of the third Society award to Scotland. He deserves our thanks and congratulations, and I am sure they are his.

This month has seen the issue of three new radiating licences and two in the "A.A." category. G6ZV has been granted to 2AVU, Mr. Hunter, of Glasgow; G6ZX to 2BTT, Mr. Brown, of Glasgow; G2AZ to 2BDT, Mr. Greck, of Edinburgh; 2ANH to Mr. Crawford, of Glasgow (BRS1003); and 2AUR to Mr. Baker, of Greenock—a new member.

Unfortunately, Mr. (or should I say "Doctor"?) Greck will not be long with us, as he returns shortly to his home in Malta, to which Colony he intends to carry the flag of radio amateurism. I am sure we wish him the best of luck.

Several new crystals were purchased in the period under review, and are as follows:—G2AZ, 7,150 kc.; G6GQ, 1,861 kc.; 2BDF, 7,180 kc.; G6IZ, crystal listed as 3,583.5 kc., was recently measured by G6NF, and was found to be 3,574.8 kc.

I am sorry that very few stations entered for the B.E.R.U. contest. Actually only G6FN and G5YG contested in the senior section, although G6IZ took part in preparation for the junior contest. In spite of a good deal of hard work, "YG" did not cut much ice, only accumulating some 132 points.

"FN" was only able to work for a portion of the second week-end, and finished with a total of 76 points. G6IZ, 6ND, 6RV, and 5ZX entered for the junior contest, and I understand that "IZ" has done fairly well, although the others have not had much luck.

The field day idea is catching and now "B" District has one on the tape for the early spring, which will be regarded as a rehearsal for the national field day. Several meetings have been held in this district, and at a recent one, fully attended, it was unanimously agreed to ask Mr. Ingram (G6IZ) to carry on as District Officer for another period. Mr. Ingram signified his willingness, and accordingly acts for 1933.

All districts continue to hold their regular meetings, and there is more enthusiasm throughout the country than there has been for years, which is rather wonderful when one considers the universal depression.

NORTHERN IRELAND

There has been more activity amongst the members in "GI" during the past month than for a considerable period. GI6YW reports only medium conditions during the B.E.R.U. contest, but he has worked Hongkong, Burma and the Swedish Polar Year expedition, as well as other Empire stations. GI5DU is active at present, and would like to hear from someone who can help him regarding Zepp. feeder lengths. GI5GV, who uses only low power, has made his first American contact.

A well-attended meeting of the Radio Transmitters' Union (N.I.) was held on January 30. The R.T.U. Trophy (known as the "Q.R.M. eliminator") was presented to GI5HV for the outstanding work he did on 56 mc. zone during the past year. It was decided that a donation from G2ZC be used to purchase a small cup, to be known as the "Houston-Fergus Trophy." This trophy to be held for one year by the GI station with the highest score in the B.E.R.U. contest. It was also decided to organise a "letter budget" in Northern Ireland. At the conclusion of the general business Mr. J. A. Sang (GI6TB) gave a very interesting talk on "Measurement," and also brought some excellent measuring instruments for inspection by the members.

STRAYS.

BRS1064 suggests the following method of fixing QSL cards to the wall, where objections are raised to the usual drawing pins in the wall. A strip of gummed tape, 1½ in. wide, is fastened by means of drawing pins between the picture rail and skirting board. The tape must be stretched taut, and a small piece of cardboard stuck to the ends will prevent the tape being torn at the points of fastening. Tapes should be fixed 5 in. apart and the cards stuck on by moistening the gummed tape.

Mr. S. S. Warne, VE5HS, 830, 17th Avenue, New Westminster, B.C., will be pleased to hear from B.R.S. members who have heard his signals, and to arrange schedules with B.E.R.U. stations.

Herr Karl Enden, Nurnburg, Bushenschlong 71, who is a young German amateur (aged 19) would like to spend two months in England this summer. His parents offer to accept as a guest, any Britisher in reciprocation for this convenience. Interested members are asked to write direct to the above address.

NEW MULTI-RANGE TEST SET

(9 RANGES)



TEST SET

AN INVALUABLE INSTRUMENT

The Scales are: Volts 10, 100, 250, 500
 Aps. I. Milliamps 2.5, 25, 100, 250. Black Bakelite Panel fitted in Solid Oak Case.

PRICE £3-15-0

This accurate and compact instrument enables you to carry out practically any D.C. test.

The "Trader" says:—The degree of accuracy attainable is very high indeed.

FREE! (for a limited period only) to every purchaser, one new Sifam Testing Prod.

SIFAM ELECTRICAL INSTRUMENT CO., LTD., YORK WORKS, BROWNING STREET, S.E.17.

Telephone: RODney 3753.



Write for complete list.

"T. & R. Bulletin." ADVERTISEMENT RATES.

Per insertion.		Per insertion.	
Full Page	£6 0 0	Half Page	£3 0 0
Quarter Page	1 10 0	Eighth Page	0 15 0

Series Discounts—5% for 6 or 10% for 12 consecutive insertions.

Advertisements specified for *Covers and Facing Matter Positions* are not subject to series discounts.

The T. & R. BULLETIN is published on the 14th of each month. Orders, Copy and Blocks should reach us by the 30th of each month for the following month's issue.

All applications for space or specimen copies should, please, be sent to Advertisement Manager,

PARRS ADVERTISING, LTD., Craven House, Kingsway, W.C.2.

Telephone: Holborn 2494.

The "WHITEHALL" range

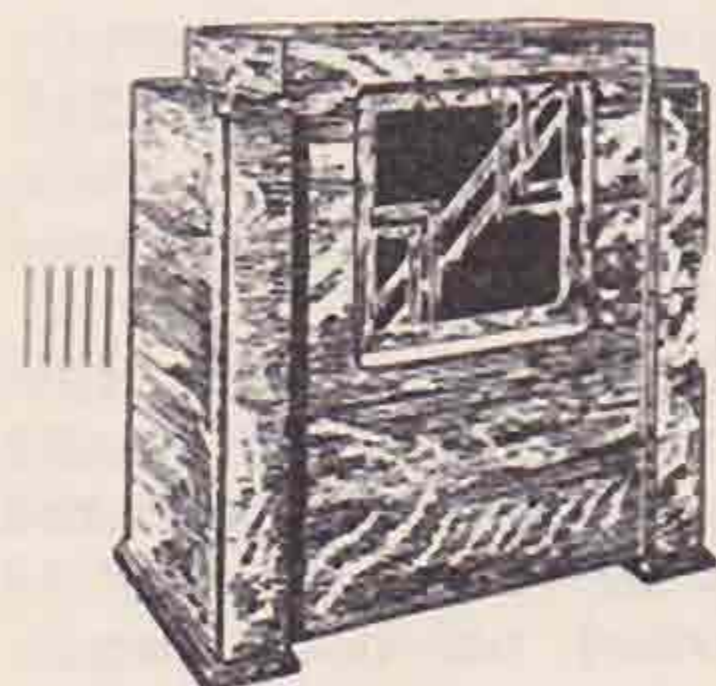

Whatever the size of your set there's a reasonably priced and handsome "Whitehall" cabinet to suit it.

WHITEHALL DE LUXE STANDARD. 16" wide, 11" deep, 17½" high. Choice Figured Oak, 30/- cash.

WHITEHALL DE LUXE JUNIOR. 14" wide, 8" deep, 14" high. Choice Figured Oak, 21/- cash. Prices for above cabinets in Walnut or Mahogany on request.

WHITEHALL GEM. 14" wide, 8" deep, 10" high. Choice Figured Oak, 16/6 cash.

Interior measurements are quoted for all cabinets.

All cabinets sent car'ge paid or C.G.D.

EASY TERMS: "Standard," 8/9 down and 3 monthly payments of 8/9. "Junior," 7/3 down and 3 monthly payments of 6/3. Write for fully descriptive leaflet "T.M."

MYERS-HUNT CABINET CO., 7, AUSTIN STREET, SHOREDITCH, LONDON, E.2

Q.C.C. Quartz Crystals.

1.75 mc., 3.5mc. & 7mc. Bands.

STANDARD TYPE (For use with up to 300v. anode voltage). POWER TYPE (For use with up to 500v. anode voltage).

15/- £1

100 Kc. QUARTZ BARS £1.

Postage Paid to all parts of the world.

We can supply crystals to within 5 Kcs. of your specified frequency, usually FROM STOCK. A calibration certificate is included with each crystal, correct to plus or minus 0.1%. (100 Kc. Bars correct to plus or minus 0.025%.)

CRYSTAL HOLDERS.

Type A

Type B

4/6

10/-

Open Type.

Enclosed Type, with base.

NOTE

Our full price list of crystals, crystal holders, transmitting inductances, H.F. chokes, standoff insulators, etc., will be sent by return of post, on receipt of your name and address on a post card.

THE QUARTZ CRYSTAL CO. (G2NH & G5MA), Kingston Rd., New Malden, SURREY, England. Telephone: Malden 0671.

Special Power Transformer for the 5-Valve All-Mains S.W. Super Het.

This new K.P. Power Transformer is produced by skilled workers to the most exact standard of laboratory precision under the personal supervision of the designers, Messrs. G. P. Kendall, B.Sc., and H. D. Price (G6HP). It is specially designed for use in the 5-Valve All-Mains Short-Wave Super-Het described in this issue, and gives an H.T. output of 200-0-200 and L.T. output of 4-v. (1 amp.) and 4-v. (5 amp.)

Price 45/-

This is just one example from our range of instruments and components for Short Wave Transmission and reception. Write for full details and particulars of H.P. terms to:—

K.P. INSTRUMENTS Aerial Works, Blackheath, S.E.3

Lee Green 5680

Empire

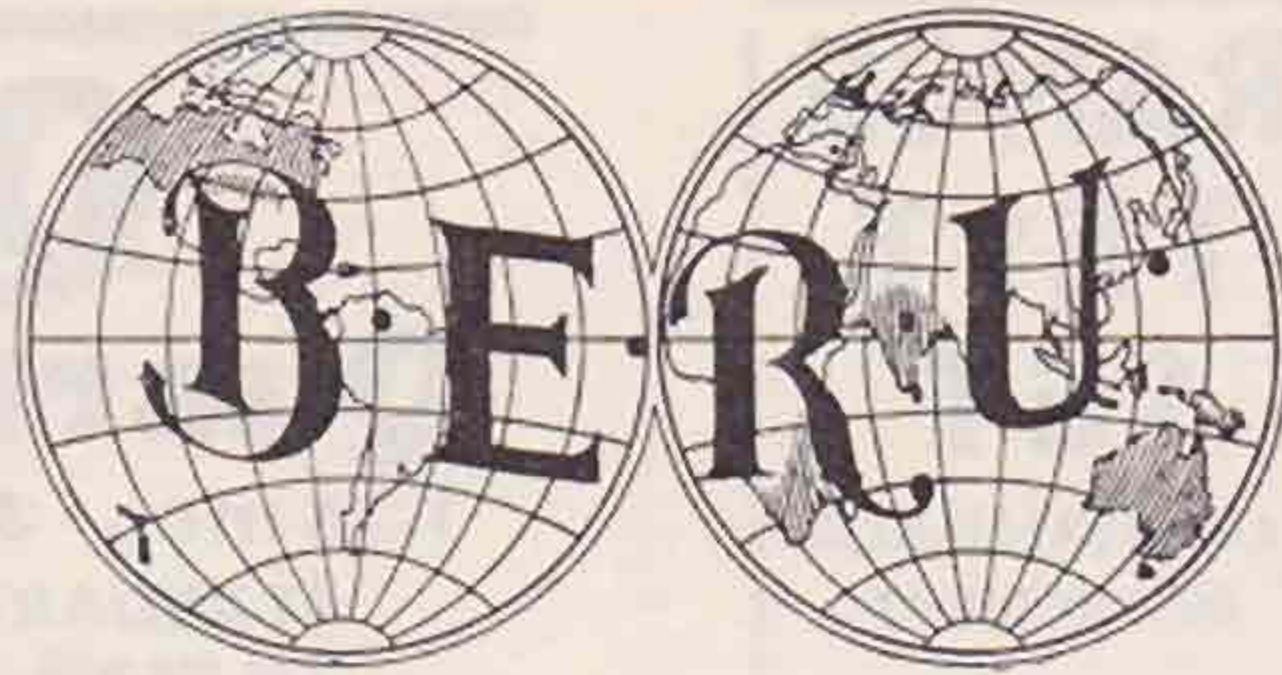

News.

B.E.R.U. REPRESENTATIVES.

Australia.—H. R. Carter (VK2HC), Yarraman North, Quirindi, N.S.W.

Bahamas, Bermuda and the Eastern Part of the West Indies.—H. B. Trasler, No. 2 Mess, Pointe à Pierre, Trinidad, B.W.I.

Canada.—C. J. Dawes (VE2BB), Main Street, St. Anne de Bellevue, Quebec.

Ceylon and South India.—G. Todd (VS7GT), District Engineers Bungalow, Nuwara Eliya, Ceylon.

Channel Islands.—H. J. Ahier (G5OU), Lansdowne House, 45a, Colomberie, St. Helier, Jersey, C.I.

Egypt and Sudan.—E. S. Cole (SU1EC), Haking House, Abbassia, Cairo, Egypt.

Hong Kong.—P. J. O'Brien (VS6AE), 12, Kent Road, Kowloon Tong, Hong Kong.

Iraq.—H. W. Hamblin (YI6HT), Wireless Section, R.A.F., Shaibah, Basra, Iraq.

Irish Free State.—Col. M. J. C. Dennis (EI2B), Fortgranite, Baltinglass, Co. Wicklow.

Jamaica, British Honduras, Turks Island and Cayman Island.—C. M. Lyons, (VP2MK), 68½, King Street, Kingston, Jamaica, B.W.I.

Kenya, Uganda and Tanganyika.—H. W. Cox (VQ4CRF), Box 572, Nairobi, Kenya.

Malaya.—T. G. Laver (VS3AC), Government Electrical Power Station, Johore Bharu, Johore, Malaya.

Newfoundland.—Rev. W. P. Stoyles (VO8MC), Mount Cashel Home, St. John's East.

New Zealand.—D. W. Buchanan (ZL3AR), 74, Willis Street, Ashburton; and C. W. Parton (ZL3CP), 69, Hackthorne Road, Cashmere Hills, Christchurch.

Nigeria.—Capt. G. C. Wilmot (ZD2A), Depot Nigeria Regt., Zaria, Nigeria.

N. India and Burma.—R. N. Fox (VU2DR), C/o VU2FX, Sgt. C. D. Connerton, Aircraft Park, Lahore Cantonments, Punjab, India.

South Africa.—W. H. Heathcote (ZT6X), 3, North Avenue, Bezuidenhout Valley, Johannesburg.

South Rhodesia.—S. Emptage (ZE1JG), Salcombe, Plumtree, Southern Rhodesia.

Australia.

By VK2HC.

SOME excellent local contacts have been obtained on 28 mc., and some ZL's were heard, early in the New Year, but have lately fallen off. VK4XN has received word from J1EZ, that the signals heard from the latter station on 28 mc. were from the fundamental and not 20-metre harmonics. 4XN heard J1EZ on October 2 last year.

The 14 mc. band for local and DX work has been very erratic, likewise 7 mc., although on the latter early morning conditions around 1900-2000 G.M.T. are generally fair. Some severe patches of QRN have upset the evening (0800-1400 G.M.T.) DX conditions. Work on 3.5 mc. is practically out of the question.

A score of amateur stations co-operated with the "Southern Cross" in its recent Tasman flight, and did good work, VK2JH acting as main VK HQ station. The new Contest rules have been received with general approval here in VK and are a credit to Council's organising ability.

Canada.

By VE2BB.

January-February.—We are glad to report that DX conditions have very much improved on 7 and 14 mc., and a number of foreign stations are now workable. VE1BV has worked his first YI and qualifies for W.B.E.

The Maritime Provinces seem to be able to work DX at almost any time, but the 2nd district are not so fortunate, whilst the other areas of Canada are very badly situated for DX work.

It was encouraging to find conditions favourable during the B.E.R.U. contest, and several good entries from Canada are anticipated. "Test B.E.R.U." is a very welcome sound in VE, and the gang here are always anxious to QSO—so keep a look-out for us.

Ceylon and S. India.

By VS7GT.

January.—The December report was unavoidably withheld and apologies are due for this.

No reports have been received this month, although VU2JP is known to be active and VS7AL believed to be so.

Excellent reception of the new Empire Broadcast Service is being obtained in Ceylon, and our hopes in this connection are now being wonderfully gratified. During the preliminary tests VU2JP and VS7GT forwarded reception reports *via* radio to the B.B.C. authorities, and it is hoped that these may have been of use.

Practically the whole of the island has this month experienced heavy monsoon rainfall, and simultaneously with these conditions has appeared a welcome revival of activity on both 7 mc. and 14 mc., DX being easily worked on both bands. Local amateurs are looking forward eagerly to a renewal of good fellowship during the B.E.R.U. tests in February next, and once again we hope to keep our zone well to the fore.

Finally, we wish fellow amateurs the Empire over the very best of good wishes and a renewal of prosperity.

Egypt.

By SU1EC.

Conditions throughout February were very good, and some high scores should have been made during the tests.

South African-Egypt contacts are always very poor, on all bands, at all times, and no higher report than R5 has been given or received during the last year.

SU1EC was the only SU station taking part in the tests, though SU6HL was on for a portion of the time. SU1CH is still QRT on amateur bands. SU6KR is now at Ramleh, Palestine, whilst SU1AQ has left for England. BERS59, working under difficulties at Alexandria, logged many G stations during the tests.

Jamaica.

[It will be remembered that the Radio Association of Jamaica were recently granted honorary affiliation with the B.E.R.U., and Mr. C. M. Lyons appointed our official representative for Jamaica, and certain other islands in the West Indies. It gives us pleasure, therefore, to present a short report from Mr. Lyons, setting out recent activities in Jamaica.—ED.]

Our association has for some time past urged the Government of Jamaica to erect a wireless station at Cayman Island, which is a dependency of Jamaica, as this group of islands is entirely cut off from the rest of the world, except by steamship communication; the islands suffer very severely each year during the hurricane season, the last storms having damaged most of the buildings on the islands. It is hoped that through our efforts this project may soon be accomplished.

Our secretary, having been appointed B.E.R.U. representative for the western section of the West Indies, and having been given Jamaica, British Honduras, Turks Island and Cayman Islands, under his section, is anxious to push matters in this part of the Empire. He will be glad if the amateurs in these islands will get into communication with him as early as possible, with the object in view of forming a radio club in each island. He hopes later on to appoint a deputy in each island, for the purpose of furnishing him with reports of activities, for publication in the BULLETIN.

STATION ACTIVITIES.

An old friend in Mr. J. Grinan (ex W2PM, 1BCG, and NJ2PZ) will soon be active again as VP5PZ. He plans to start up during March on the 14 mc. band, using a M.O.P.A. equipment. Mr. D. Dun, VP5DD, has been on vacation, but will be heard shortly on both 7 and 14 mcs. Mr. C. Corinaldi, VP5CC, has commenced work on a new receiver, having loaned his older set to a "budding" member for the past few months. Mr. C. L. Isaacs, VP5PA, recently "blew up" his transmitter, but is rebuilding, and should soon be heard using his M.G. outfit. Another "casualty" occurred when Mr. G. MacCulloch, VP5GM, burnt out his mains transformer, but a new one is on its way from England, and his call will soon be heard again.

Mr. W. H. Stephens, VP5IS, whose station was, we believe, heard more frequently than any other VP5 during the B.E.R.U. contest, has recently installed a C.C. outfit. He also has had bad luck when a 2,000 volt filter condenser went down during January.

The rest of the VP5 stations have been active spasmodically, but many of them anticipate being on the air regularly during the summer. Most of us use low power and work between 1600 and 2400 E.S.T., but we are all anxious to effect contacts with other B.E.R.U. stations and invite schedules.

New Zealand.

By ZL3CP.

A very successful Convention was held in Dunedin on December 26, 27 and 28, and for the first time all districts were represented.

On Monday, the 26th, a picnic was arranged on an island in Otago Harbour, and the usual sports were run off. The Marks Cup for the N.Z. Amateur Championship was won by J. H. Gault (ZL4FI), whilst a code contest was won by C. J. Banwell (ZL3AD). On Tuesday, the 27th, the Conference took place in the Otago Branch club rooms. The annual report and balance sheet, presented by N. W. Laugesen (ZL3AS), showed great progress during the year, and a satisfactory financial position. On Tuesday evening the Hamfest was held in the Somerset Lounge. This function set a standard that other districts will have to work very hard to equal. Musical items were given by ZL4CL, 4DT and 4FN, and a conjuring display by ZL3AS and 3CL, whilst a number of very personal limericks were sung by the Otago Gang Sextet.

On Wednesday morning the visitors were taken on a 'bus tour around the Otago Peninsula, and during the afternoon various broadcasting and amateur stations were visited.

An "au revoir" party, with ZL4BY as host, concluded the Convention.

Nigeria.

By ZD2A (via G5LA).

Conditions here have been slowly getting worse recently on all bands. During the last two weeks of the B.E.R.U. Contest, the 14 mc. band was "dead" during darkness, whilst on 7 mc. QRN was very bad. No VK or ZL stations were heard during the Tests.

ZD2A was seriously handicapped by numerous non-Empire stations who answered his "Test BERU" calls. Reports from B.E.R.U. members here show that the Empire Broadcaster is generally well received.

South Africa.

By ZT6X (via G5ML AND ZU6W).

The wonderful and successful flight of the "Fairy Monoplane" was keenly followed by all divisions. At times great difficulties were experienced in copying the complete messages sent by the 'plane whilst in flight owing to QRM, but by correlating all messages picked up, ZU6W was in nearly every case able to complete the messages. Great credit is due to ZU6W and G5ML for the ground work they performed before and during the flight, and to the members of the S.A.R.R.L. who stood by during the duration of the flight.

The air was humming with "Test B.E.R.U." calls during the senior contest, and at times it was difficult to QSO owing to the number of stations on the air. With the exception of Canada, all dominions came in well. During the first week of the junior contest things were rather on the quiet side, and contacts were few and far between.

EXCHANGE & MART.

Rates 1d. per word, minimum 1/6. First line in capitals if desired. 2d. per word where all capitals are required. Minimum 3/-.

STAMPS.—Regular Correspondents wanted in all countries to send me New Issues, especially air mails and commemoratives, mint and used.—E. R. RUSSELL, 32, Somerset Avenue, Hook, Surrey.

REAL D.X. Eddystone Atlantic Three, with additional 15 m. mfd. VC. in parallel to spread Bands. Metal panel secondhand, rest all new Eddystone components. Includes new P.M. 12, H.L. 210, P.M. 22, battery leads, 8 coils covering 12/1800 metres, and the latest 59s. 6d. Blue Spot 99 P.M. Moving Coil Speaker. Cost £11 10s. Sacrifice, £8 cash, or would exchange for equivalent value in new or little-used specified components of Q.R.P. C.C. Tx., described in BULLETIN, May-June, 1932.—SPOONER (BRS1040), 18, Warwick Road, Boscombe.

MORSE INSTRUCTION—Day or Evening. Easy terms. Special course for beginners; faulty formation; and advanced students.—TELEGRAPH SCHOOL, 29, Talfourd Rd., Peckham, S.E.

H.T. GENERATORS FOR SALE.—P. A. F. Silent geared 500 and 4-volt, 30s.; Evershed W.A.C.-W.B.E. 600-volt, 30s.; as last, for belt drive, 20s.; Foot-pedal drive for first two, 10s., carriage forward.—G5BD, Mablethorpe.

FOR SALE.—M.L. Rotary Transformer, type FEH, input 12 volts, output 1,000 volts 50 M.A.; in splendid condition; cost £14. Also Mullard D.O. 40, practically new.—Offers to G5JK, Seafield House, Aberdeen.

TANTALUM AND LONIUM.—Make your own Battery Chargers for alternating current. Simple, reliable. Lionium Rectifying Electrodes, 2-4 amps., 10s., 5-10 amps., 15s. Also Transformers, Blue Prints, 1s. each, and complete Chargers.—BLACKWELL'S METALLURGICAL WORKS LD., Liverpool.

QUARTZ OSCILLATING LENSES, 2s. 6d.—SMITH, Bryn Rodyn, Colwyn Bay.

PATENTS AND TRADE MARKS.

PATENTS obtained, Trade Marks and Designs registered, British and Foreign.—GEE AND CO., Patent and Trade Mark Agents (H. T. P. GEE, Member R.S.G.B., A.M.I.R.E.), 51-52, Chancery Lane, London, W.C.2. Telephone: Holborn 1525.

A. MATHISEN, B.Sc. (Elect. Eng.), Specialist. Patents for Television, Radio Engineering Inventions.—FIRST AVENUE HOUSE, High Holborn, London, W.C.1.

FOR SALE.—Delco Lighting Plant, 32 v. Storage. M.L. 32 v. input, 1,000 v. 50 Ma. output. G.E.C. 32 v. input, 400 v. 100 Ma. output. Complete or separate.—CORY, Sutton-on-Sea, Lincs.

G6VP.—Phones, Transformers Rewound; Brown's "A" a speciality; any resistance; 24-hour service. Lowest terms in the trade.

FOR SALE.—½ h.p. 230v. D.C. totally enclosed shunt-wound Motor. 1,700 r.p.m. Pulley diameter 3 in. £2 10s.—G2LC, 19, Lincoln Gardens, The Drive, Ilford, Essex.

TRANSFORMERS ARE CHEAPER IN THE SPRING! Note these special models. 1,000-0-1,000 250 watts. Regulation 5 per cent., 42s. 500-0-500 100 watts, 22s. Here is a good choke. 20 henries at 200 Ma. resistance, 140 ohms, 14s. Filament transformers to your specification. All goods sent carriage paid.—WILLIAMS TRANSFORMERS, 71, Hervey Road, Blackheath, S.E.3. Telephone: Greenwich 1285.

CLEARANCE SALE.—Autoplex Bug Keys, 10s. 6d., originally 25s.; .0001, 2,000-volt Brass Transmitting Condensers, soldered vanes, 5s. 6d.; Pyrex Bowl Lead-in Assembly, 5s.; all c.w.o. Money returned if not satisfied.—G2MA, MARSHALL, 41, Kelvinside Gardens, Glasgow.

MORE BARGAINS.—L.F. Chokes, 30 Henries at 40 mills., 3s. 6d.; Output Transformers, easily adaptable for Q.P.P., three ratios, diagram with each, 5s.; 10,000-ohm, 25-watt Resistances, 1s. Over 10s., postage paid.—CENTRAL RADIO, Mossgrove, Bridge of Allan.

5NI'S MONTHLY SELECTION OF "SNIPS," whether for "ham" gear or B.C.L. requirements. Get our quotation first.—Below.

BRAND NEW T.C.C. 1,700 WORKING 4+4 mfd. CONDENSERS, with massive stand-off insulators. Ideal for use with GU1's. To-day's value £8. A few left at 25/-. Ask the man who's bought one; we've even had American orders.

BRAND NEW 1,500-VOLT HALF-WAVE RECTIFIERS; two give 250 mills.; another snip, 10s. each.

TWIN .0001 CONDENSERS, all brass: ideal as series-gap or 56 mc. transmitting double spaced. While they last, 2s. 6d.

HYDRA (SECOND-HAND) 2,000 VOLT TEST 2 mfd. Stand-off Insulators; real quality goods, 7s. 6d.; T.C.C. ditto, 800-volt working, 5s.

T.C.C. AND HELSBY 400 D.C., 250 A.C., 4+4+4 +2+2, or 6+2+2+2, 12s. 6d.; 4 mfd., 3s. 9d.; 250 D.C., 4+4+1, 5s. 9d.; 1+.2, 1s. 3d. Many others; all brands new, up to 800 working.

GENUINE SANGAMO 1,000-V. BY-PASS CON- DENSERS famous for standing up to R.F. Why pay 5s. 6d.? Our price 1s. Polymet .002 for filament by-pass, 6d.

SPECIAL HIGH RESISTANCE H.M.V. ANODE CHOKES. Ideal for S.G. detector coupling, 2s. 6d.

WE CARRY THE MOST VARIED STOCK in the Midlands of Meters, Transformers, Moving Coils, Valves (Heavy Duty), Bleeder, and other Resistances, at prices beloved by true hams.

WHILST NOT DISPLAYING THE TRADI- TIONAL "BRASS BALLS," we buy, sell, and swap all classes of B.C.L. and "ham" gear. We Guarantee Satisfaction.—RADIO MART, 19, John Bright Street, Birmingham.

SPECIFIED.....

for the T & R Five Valve All-Mains Super-Heterodyne Receiver

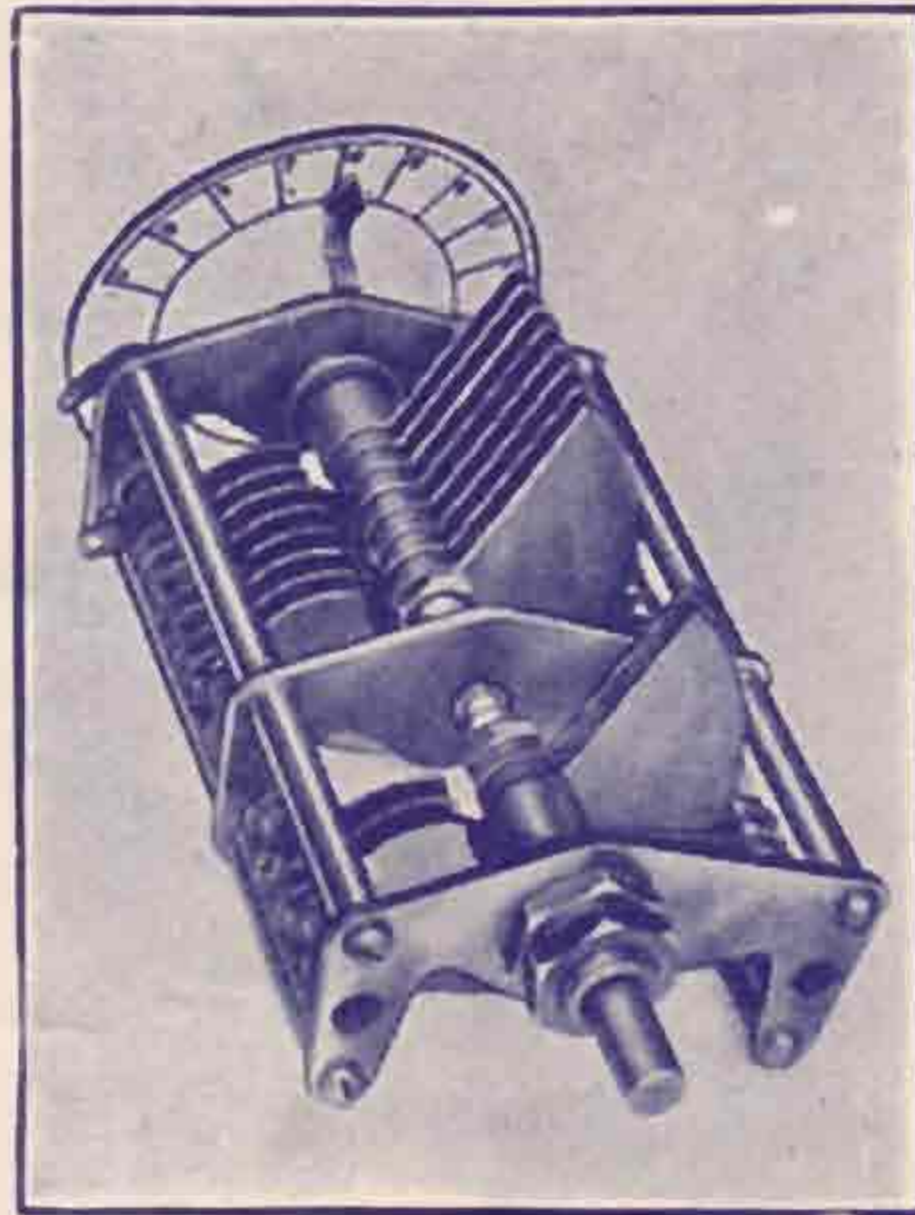

Polar Type 'A' Short Wave (Two Required)

Designed and built expressly for the 15 metre band and upwards, this condenser is constructed in two sections—the "Tank," controlled from the rear, tunes to the desired waveband, while the "Tuner" of 20 mmfds., operated from the panel by a slow motion drive provides the necessary selectivity required. Specially designed silent bearings. One hole fixing.

* Polar Disc Drive recommended, 5/-.

"Tank" Cap. .0001

"Tuner" Cap. .00002

15/-

Polar 'Pre-set' (One Required)

Accurate and easy knob control. Reliable and efficient with setting secured by lock nut. .0001 max. **1/6**



Send for
POLAR
Leaflet

POLAR

CONDENSERS

WINGROVE & ROGERS LTD.

188 9 STRAND, LONDON, W.C.2

POLAR WORKS, LIVERPOOL

YOU CANNOT SUBSTITUTE CYLDON AND STILL EXPECT CYLDON PERFORMANCE

STANDARD CYLDON SERIES-GAP CONDENSERS AS ILLUSTRATED.

CYLDON SERIES-GAP Condensers are acknowledged by their performance alone as the world's finest short-wave condensers. Their remarkable power factor is achieved by the use of superfine materials, perfect insulation, CYLDON rigidity of construction, and true mathematical precision in assembling. Each condenser is rigorously tested over every stage of manufacture. Exclusive CYLDON Features include: no pigtail; absolute silence in operation; no backlash; and provision for earthing framework to cut out all hand capacity. That is why Series-Gap Condensers remain the world's best condensers designed specially for short-wave reception.

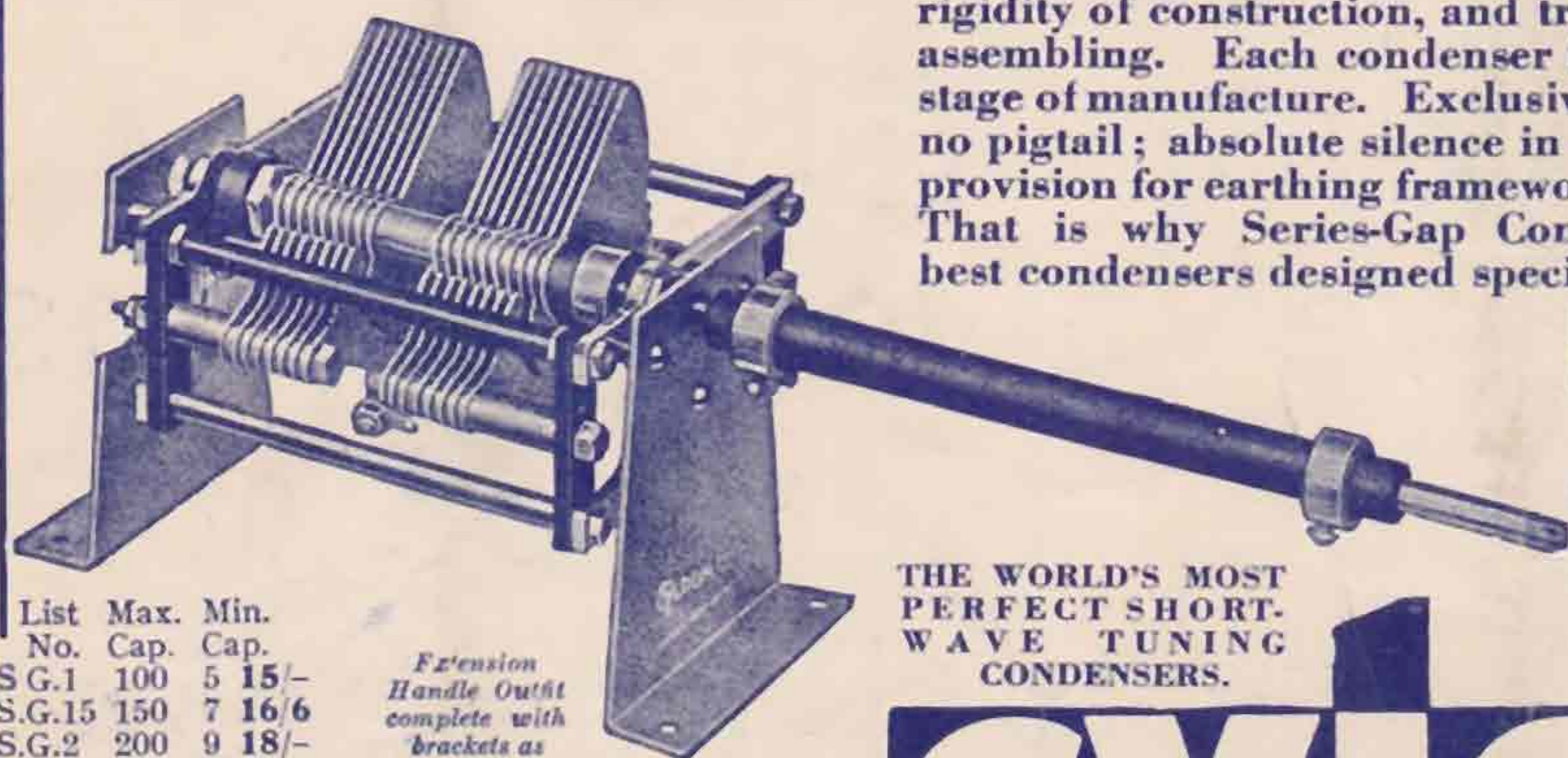

THE WORLD'S MOST PERFECT SHORT-WAVE TUNING CONDENSERS.

CYLDON BEBÉ SERIES-GAP CONDENSERS.
 CYLDON'S latest triumph—a condenser for 5 metre working.—It's successful because it's CYLDON.
 Max. cap. 25 mmfds. **8/6**
 Min. cap. 3 mmfds.

CONDENSERS BUILT TO SPECIFICATION AT SPECIAL RATES.

List No.	Max. Cap.	Min. Cap.	
S.G.1	100	5	15/-
S.G.15	150	7	16/6
S.G.2	200	9	18/-
S.G.25	250	12	19/6
S.G.02	20	4	14/-

Extension Handle Outfit complete with brackets as shown 4/6 each.



FIVE YEARS GUARANTEE

There's a CYLDON VARIABLE TRANSMITTING AND RECEIVING CONDENSER for every possible requirement. Send for the CYLDON Catalogue.

SYDNEY S. BIRD & SONS, LTD.,
 CYLDON RADIO, HIGH ROAD, WHETSTONE, LONDON, N.20.
 Phone: Hillside 2244.

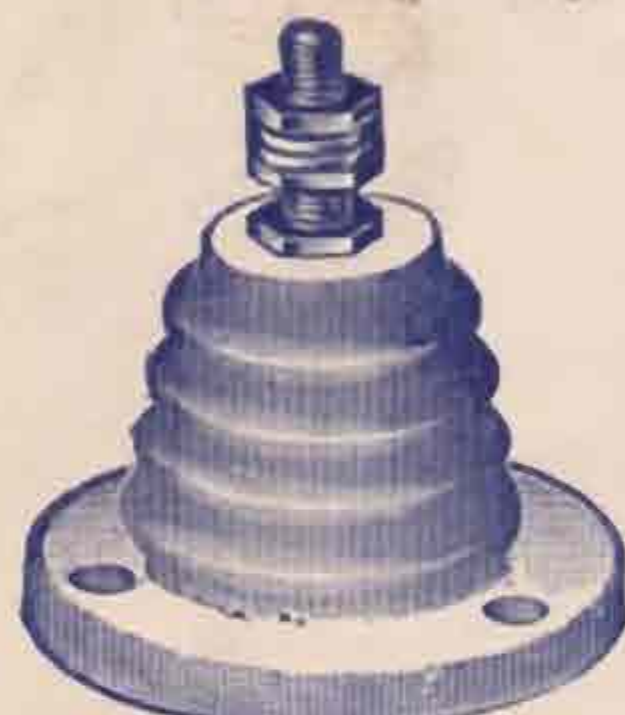
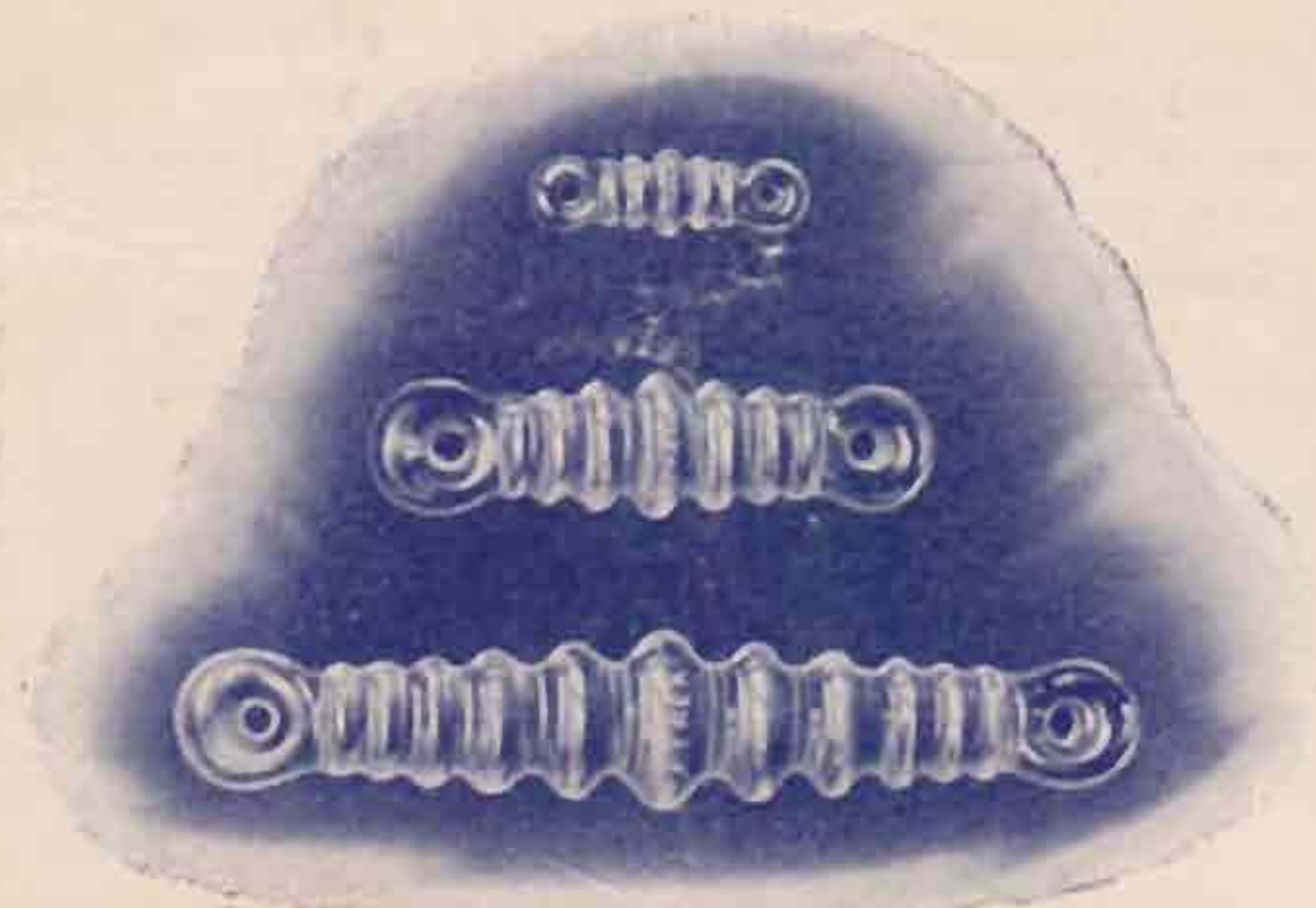

12" for 1: Kw. .. 14/6 each.
 6 1/2" for up to 250 W. 6/3 "
 3 1/2" for Q.R.P. .. 9/1 "

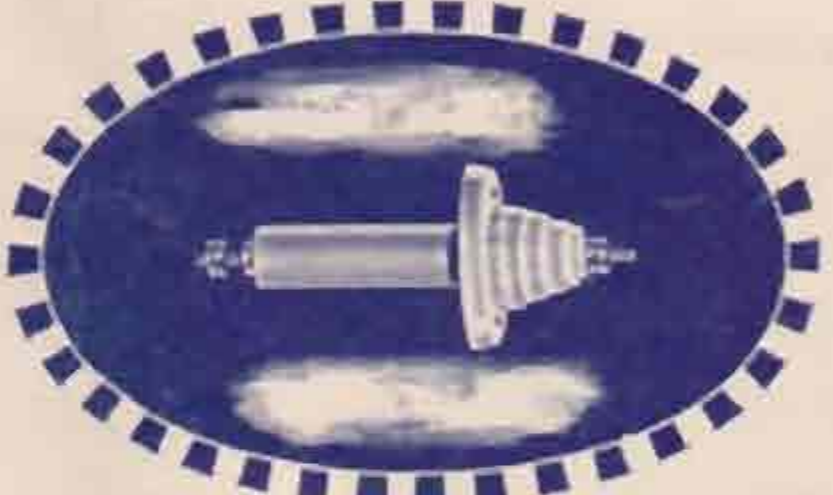

Beehive Type Insulators. White Porcelain, 9/1 each.
Green Porcelain Lead-in Insulator. 8" long, 1/9 each.

Zepp Feeder Spacers with screw down metal clamp. 3/- per set of 5.

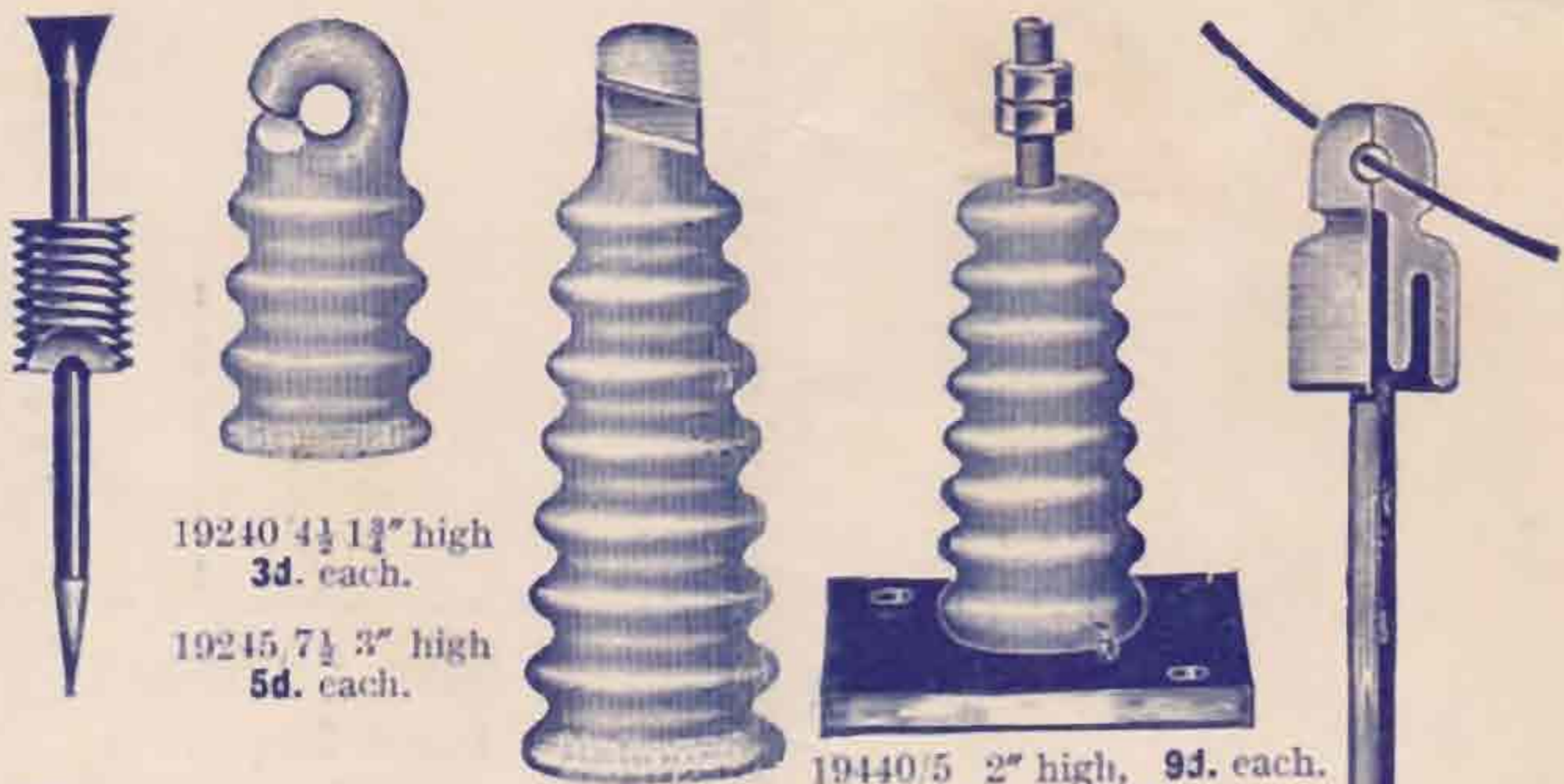

19240 4 1/2 1 1/2" high 3d. each.
 19245 7 1/2 3" high 5d. each.

19440/5 2" high, 9d. each.
 19445 7 1/2 3" high, 11d. each.
 19450 10 4" high, 1/2 each.

10073 12" long, 1/- each.
 10079a 20" long, 1 2 each.

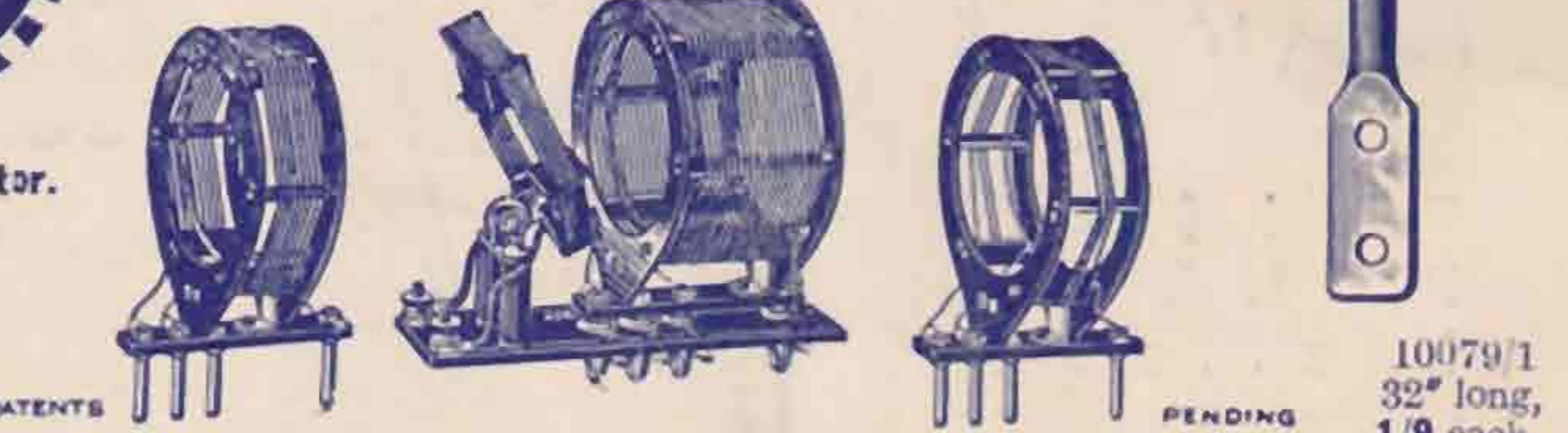

S.W. Coil Unit. 15 to 130 metres, 30/- per set.
Transmitting Inductances: Copper burnished and lacquered: 3/16" x 3" diam., per turn 3 1/2d. 1/4" x 3" diam. 4 1/2d. As above but Silver-plated, per turn, 7d. & 8d.
 68ft. Enamelled Aerials, 2/6 ea. **Reisz Type Microphones,** with transformers, £3 15s.

LOOMES RADIO (G6RL, G6US), 32-34 Earls Court Road, W.8. 'Phone: Western 0344.