

R·S·G·B

BULLETIN

JOURNAL OF THE RADIO SOCIETY OF GREAT BRITAIN

November 1946

The original front cover for this edition was not available.

The original front cover for this edition was not available.

R.S.G.B. BULLETIN

OFFICIAL JOURNAL OF THE INCORPORATED RADIO SOCIETY OF GREAT BRITAIN

Published on or about the 15th of each month. Issued free to members.

Editor : JOHN CLARRICOATS.

Editorial Office :
NEW RUSKIN HOUSE,
LITTLE RUSSELL STREET, LONDON, W.C.1
Telephone : Holborn 7373.



Advertisement Manager : HORACE FREEMAN

Advertising Office :
PARRS ADVERTISING LTD.,
121 KINGSWAY, LONDON, W.C.2
Telephone : Holborn 2494

Honorary Editor : ARTHUR O. MILNE.

VOL. XXII

NOVEMBER, 1946

No. 5

THE TECHNICAL SIDE

FOR months past the Council has been giving the closest possible attention to the technical side of Society life and although members may think that there is little yet to show, they may rest assured that a good deal of spade work is being done by the Technical Publications Committee, which is the Committee of the Council delegated to deal with the technical programme.

It is now eight years since the *Amateur Radio Handbook* made its first appearance with an edition of 3,000 copies. That publication, as Old Timers are aware, grew out of *The Guide to Amateur Radio*—a little sixpenny booklet that turned up, in revised form, at each of the Radiolympia shows from 1933 until 1937. In view of the steadily increasing demand for technical information, the 1940 Council authorised the preparation of a second edition of the handbook, and it says something for the enthusiasm of the contributors that they were able to meet their commitments in spite of serious war-time difficulties. The second edition eventually became one of the nation's best selling books—no less than 181,000 copies having been sold to date.

During the year 1941, the Council realised that a great demand existed for additional technical and mathematical information and in an effort to meet that demand they authorised the preparation of a new publication which is now familiar to all members as the *Radio Handbook Supplement*. Like its companion volume, the Supplement has had very large sales—115,000 copies.

With a return to peace-time conditions the Council gave immediate consideration to a recommendation of the Technical Publications Committee that the two volumes should be merged, revised and new material prepared. This recommendation was accepted, but it soon became apparent that some time must elapse owing to the very considerable amount of work involved before a third edition of the Handbook can be published. As an alternative it was decided to prepare a series of technical pocket books which would deal with specific aspects of Amateur Radio.

The initial step, of course, was to find teams of willing horses. This was no easy task, but we are happy to announce that no less than 12 of the most experienced amateurs in Great Britain are now at work. Each book is being prepared under the joint editorship of two specialists—for example, Messrs. F. Charman, B.E.M., G6CJ and J. M. Kirk, G6ZO,

are co-editors of a book dealing with aërials—but in order to make the books as comprehensive as possible the editors have taken it upon themselves to approach other members of the Society for details of their equipment. Generally speaking each book will be biased towards the constructional rather than the theoretical side of the subject it is intended to cover.

This is where *you* come into the picture! We invite every member who considers he has some item of equipment that is worthy of a place in one of the new booklets to communicate with Headquarters forthwith. Photographs and brief descriptions are required initially. If the particular item is considered to be of sufficient general interest the co-ordinating editors will ask for further information and possibly additional photographs. Council intends to award honoraria to those who furnish material which is used in the booklets.

The following is a complete list of the books which are at present being prepared, together with the names of the co-ordinating editors.

- No. 1.—*Aerial Systems*.—Messrs. F. Charman, B.E.M., G6CJ, and J. M. Kirk, G6ZO.
- No. 2.—*Short Wave Transmitters*.—Messrs. F. Charman, B.E.M., G6CJ, and W. H. Allen, M.B.E., G2UJ.
- No. 3.—*Ultra Short-Wave Equipment*.—Messrs. A. J. Bayliss, B.Sc., G8PD, and E. J. Williams, B.Sc., G2XC.
- No. 4.—*Short-Wave Receivers*.—Messrs. A. O. Milne G2ML, and R. H. Hammans, G2IG.
- No. 5.—*Measuring Equipment*.—Mr. E. L. Gardiner, B.Sc., G6GR, and A. N. Other.
- No. 6.—*Microwave Technique* (above 500 Mc/s).—Messrs. J. H. Shankland, B.Sc., G8FM., and E. D. Hart, M.A.
- No. 7.—*Modulators and Audio Equipment*.—Mr. H. A. M. Clark, B.Sc.(Eng.), G6OT, and A. N. Other.
- No. 8.—*Valve Technique*.—Mr. D. N. Corfield, D.L.C.(Hons.), G5CD, and A. N. Other.

The Technical Publications Committee will be glad to receive offers of assistance from specially qualified members able to undertake the work of assistant co-ordinating editors for booklets Nos. 5, 7 and 8. In addition the Committee will be pleased to consider suggestions for additional subjects.

THE REMAINDER OF THE 7 AND 14 Mc/s BANDS ARE NOW RELEASED

TOP-BAND TWO TRANSMITTER

By J. N. WALKER, (G5JU).*

THE equipment described below has been designed to meet a variety of requirements. Essentially, it is a completely self-contained low power transmitter, very suitable for construction by the newly-licensed amateur. As experience is gained, the latter will wish to expand his station and this unit can then become an exciter stage. Incidentally, there are many points in favour of using an exciter which possesses its own power supply.

Whilst intended primarily for use within the 1·8 Mc/s. amateur band, it is equally efficient on 3·5 Mc/s., and on the frequencies likely to be used by the various Service Reserves and fulfils all the requirements called for, such as break-in and high reliability. Operation is also possible in the 7 Mc/s. band, at somewhat reduced efficiency.

Several novel features have been incorporated, partly with a view to simplification and partly to enable it to be used for other purposes. These features are the use of (a) a Pierce oscillator circuit, which eliminates one tuning control (b) self-bias throughout, (c) capacitive coupling between output and aerial circuits, (d) junction block connection to power supplies.

The transmitter is flexible as regards the valves that may be used in it—a number of types have been tried, the best combination being a 6V6 as crystal oscillator, followed by a Mullard EL37 as amplifier.

* Stratton & Co., Ltd.

It is recommended that the 6V6 be retained as C.O., but any beam power tetrode will be found to give good results as an amplifier.

The Circuit

The complete circuit diagram is given in Fig. 1. The first valve is connected as a Pierce oscillator, in which the crystal itself forms the tuned circuit and no tuning coil or condenser is necessary. The crystal is placed across grid and anode, with a condenser in series to remove the standing D.C. potential from the crystal. A small resistor, R3, soldered directly to the valveholder pin, prevents parasitic oscillation. Bias is secured by a combination of cathode and grid leak resistors and this valve is at all times much under-run. R4 in the anode circuit serves as both decoupling and voltage dropping resistor.

Capacitive coupling to the power amplifier is used. Again, a combination of resistors provides grid bias and it is not possible, under normal circumstances, to over-run the valve. An anti-parasitic resistance is included in the anode circuit and both screen grid and anode circuits are effectively decoupled, the former by R8 and C8, the latter by RFC2 and C11.

It would be possible to connect the aerial to a tap on the P.A. anode circuit, but this practice is not advisable, as it tends to make tuning somewhat more difficult; furthermore it may cause interference

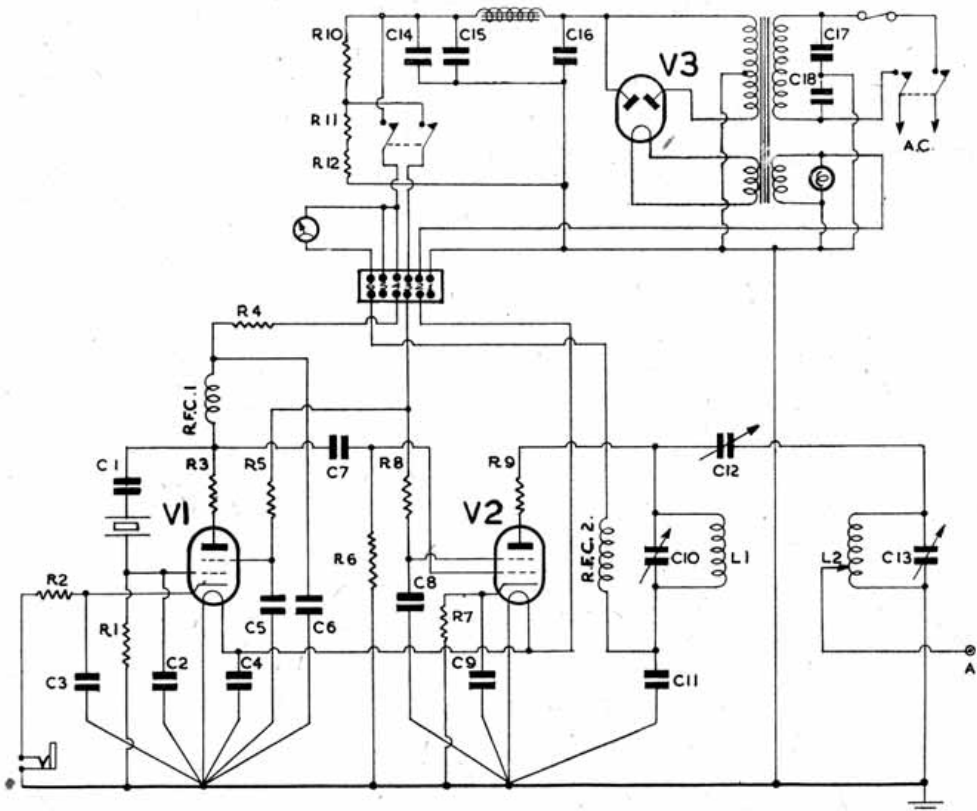

Fig. 1.

Circuit Diagram of Top-Band Two Transmitter. See Components List for values of components used.

to broadcast receivers. A separate aerial circuit should always be used but difficulties crop up in coupling between the aerial and output circuits. Link coupling is good, but it complicates the mechanical design of the coils unless it is intended to work on one frequency band only. The number of turns in the link winding also will vary from band to band. The somewhat unusual method of top-end capacitive coupling has therefore been employed. This enables the coil design and mounting to be simplified in that one winding only is required in both tank and aerial coils whilst the degree of coupling is easily adjusted. The system works well and no disadvantages have become apparent.

The power supply circuit should be studied carefully. When using a combined H.T. and L.T. transformer, the normal method of switching off H.T. during stand-by periods is to break the H.T. winding centre tap to chassis. This involves the sudden application of H.T. to the smoothing condensers, and is probably the cause of many a breakdown of these components. It is better to leave the voltage across these condensers, but with bleeder resistors connected so that no high voltage builds up (as is

prevent it, in this instance, condensers C17 and C18 are connected across the primary of the mains transformer. These should be rated for at least 500 volts working. The primary circuit also includes a 1 ampere safety fuse and a double-pole switch which, when off, completely disconnects the A.C. supply from the equipment.

The transformer used in the transmitter (illustrated in Fig. 2) gives a smoothed H.T. output of 300 volts, which is about right for operation of the transmitter at an input of 10 watts in the 1.8 Mc/s. band. If it is intended to operate on higher frequencies, where a greater input is permitted, the transformer should be chosen to give up to 400 volts smoothed H.T. In the latter case, the value of R4 will require increasing so that 250 volts on the anode of the first valve is not exceeded.

The bleeder resistance values have been chosen to give a screen voltage of 150, which is suitable for the majority of beam tetrode valves. In the transmitter illustrated, R11 and R12 have been used as a matter of convenience but they may well be combined into a single resistor of 10,000 ohms, rated at 5 watts.

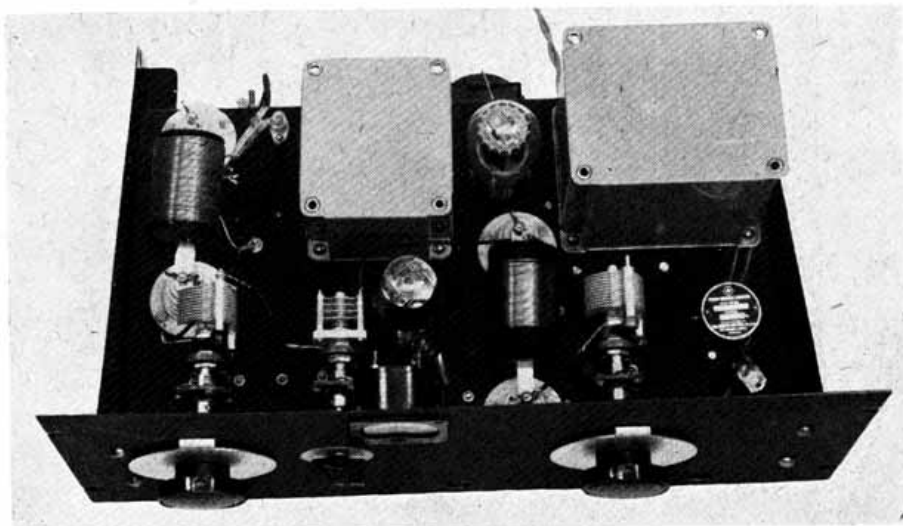

Fig. 2.
Plan View from above of Transmitter.

possible with a condenser input filter). The bleeder resistors are also used as a potentiometer to supply a reduced voltage to the screen grids of the valves. Note that switching off the H.T. to the anodes of the valves only, is likely to damage them. A double pole switch is therefore required to disconnect H.T. from both anodes and screens simultaneously, but still leaving the bleeder resistors in circuit.

When carrying out experimental work, it often happens that a readily accessible power supply is called for. Mainly for this reason, the connections from the power supply components have been wired into one side of a *Grelco* 6-way block, the wiring to the valves being taken from the other side of the block. These leads are therefore easily detachable and loose ones can be taken to the experimental apparatus from the block. The meter in the anode circuit of the P.A. valve may or may not be included at will in the external circuit, depending on whether the loose lead is screwed into outlet 5 or 6.

Radio frequency current travelling back through the mains supply is a common but often unsuspected cause of interference to broadcast receivers. To

Construction

Bearing in mind the difficulties of present day supplies, the transmitter has been built with components which are obtainable fairly readily. Substitution may be necessary occasionally but the design as a whole should be followed as closely as possible.

The chassis, front panel (8½ in. deep) and side brackets are of mild steel, of international standard size, the whole forming a strong, rigid assembly. The upper chassis view of the transmitter, Fig. 2 shows the layout adopted, the crystal oscillator stage being on the extreme right, the P.A. stage in the middle and the aerial tuning circuit on the left. The mounting holes for the adjustable brackets are drilled 2¼ in. from the front of the chassis, which distance will ensure that the slow motion dials fitted to the tuning condensers C10 and C13 and the flexible couplers fit correctly to the condenser spindles. C10 is mounted 4½ in. and C13 mounted 2½ in. from the edges of the chassis. The aerial coupling condenser C12 is fitted 3½ in. to the right of C13. The positions of the other components are by no means

critical and may be judged from Fig. 2. It should be noted that the stand-off insulators holding the coils are mounted $4\frac{1}{2}$ in. apart and are so placed that the wing nuts are easily accessible for rapid coil changing.

All necessary holes for mounting the mains transformer and choke should be made when other holes are drilled but the two components themselves should not be fixed until the wiring has been nearly completed, so allowing the chassis to be handled with greater ease.

The positions occupied by the various condensers and resistors below the chassis can be seen in Fig. 3. The mica condensers are bolted to the chassis through the holes provided in the moulded cases. Tag strips are provided where necessary to hold resistors, R.F. chokes, etc., the valveholder tags also serving the

brackets. A small knob controls the coupling condenser through an insulated coupler—a $\frac{3}{8}$ in. hole is necessary in the panel to take a bush.

The appearance of the transmitter would possibly be improved if the meter was mounted centrally, but in such a position it would interfere with coil changing. The meter is therefore offset and is located 8 in. from the left hand edge of the panel (not chassis).

A miniature stand-off insulator is fitted at the rear of the chassis, near the aerial coil, and acts as an aerial terminal.

Wiring

The circuit diagram Fig. 1, indicates that the earthy sides of all the fixed condensers associated with the crystal oscillator valve V1 have been returned to one single point on the chassis. This feature is

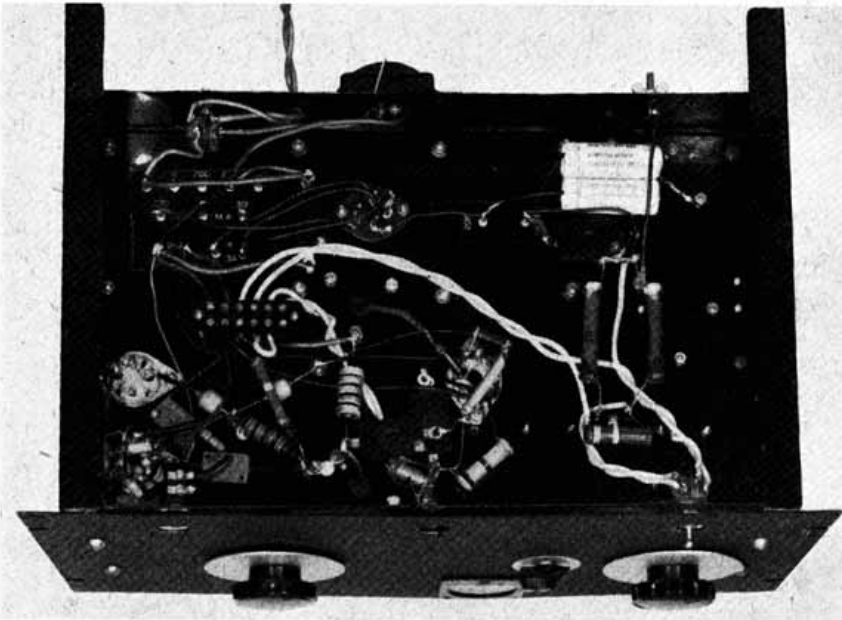

Fig. 3.
Underside View of Transmitter.

same purpose. The 6-way *Grelco* block previously mentioned is fitted conveniently near the mains transformer.

Holes, $\frac{3}{8}$ in. diameter, to take rubber grommets are required beneath the tank coil stand-off insulators, since leads to anode and H.T. pass through the chassis at these points. The same applies to the leads for the meter. The mains transformer and choke are of the sub-chassis wiring type. If leads have to be brought through from top connections further holes and rubber grommets will be called for, at least for those leads carrying high A.C. and D.C. potentials.

At the rear of the chassis are fitted the mains on/off switch, the fuse holder and an earth terminal. The mains leads are brought out through a $\frac{3}{8}$ in. hole fitted with a rubber grommet. On the front are the keying jack (of the open circuit type) standby switch and panel indicating light. These three items are bolted to the chassis proper and $\frac{3}{8}$ in. clearance holes, in appropriate positions, should be made in the front panel.

The slow motion dials require holes $13/16$ in. in diameter, 4 in. from the top of the panel. When marking out, care should be taken that their positions are accurate in the horizontal plane—errors in the vertical plane can be taken up by the adjustable

important and is one which it is well to follow when constructing any piece of radio equipment. It prevents circulating R.F. currents in the chassis and, by removing the cause of undesirable coupling effects, increases the overall electrical stability.

A stout soldering tag (or several small ones) should be fitted beneath the valveholder fixing bolt remote from the edge of the chassis and to this tag separate wires are soldered from pins 1 and 2 of the valveholder and from condensers C2, C3, C4, C5, and C6.

The same principle is adopted in the case of the second valve. C8, C9 and C11 (one bolt serves to fix all three condensers to the chassis) and pins 1 and 2 of the valveholder are all connected to an earth tag fitted beneath a fixing screw.

The low potential side of the aerial tuning combination L2, C13 is earthed, at one common point only, to a tag fitted beneath a 4BA bolt. From the underside of this bolt a wire is run direct to the earth terminal at the rear.

Before fixing the tank coil stand-off insulators, loops of flexible wire should be fitted beneath the bolt heads inside the hollow portion and led through the chassis. The lead nearer the panel is soldered to a tag strip and thence connects *via* the R.F. choke to outlet 6 in the *Grelco* block. The other lead

goes via R9 direct to tag 3. Both R9 and R3 are soldered directly to the valveholder tags with very short wires.

The remainder of the wiring is straightforward. Heavy gauge wire, either solid or flexible, should be employed for the heater and R.F. tuned circuits, 20 s.w.g. tinned wire enclosed in insulating sleeving serving elsewhere. Good quality flex is advisable for the meter and mains leads.

When all other wiring has been completed, the mains transformer and choke are bolted into position and wired in.

Coils

The coils, both tank and aerial, for use on the 1.8 Mc/s. band consist of 50 turns 20 s.w.g. enamelled wire on paxolin formers, 2½ in. diameter. Strips of brass, approximately 1½ in. long by ½ in. wide, are bolted to the ends of the coil and holes drilled so that they fit over the 2BA bolts in the stand-off insulators. Four tapings at the earthy end are wanted on the aerial coil to accommodate different lengths of aerial. The first tapping is 4 turns from the end, the others each 4 turns further away.

For operation on frequencies generally used by the Service Reserves, similar coils, but consisting of 40 turns will be suitable.

On 3.5 Mc/s. 2½ turns are required, and, as the formers will then take a heavier gauge of wire, 16 or 18 s.w.g. enamelled copper wire should be used. The tapping points in this case should each be three turns apart.

The coils for 7 Mc/s. operation should be either of the self-supporting type or wound on a ribbed former. The number of turns required is twelve assuming a diameter of 2½ in. or ten if of 3 in. diameter. The aerial coil should be arranged so that it is possible to tap on to each turn separately.*

Operation

After connecting up the mains supply, ensure that the heaters of the valves are receiving the correct voltage (6.3 or near). Closing the stand-by switch will apply H.T. to the valves and, with the cathode circuit of V1 open, the meter in the anode circuit of V2 should indicate a current of approximately 30 mA. This continual drain will do no harm—in fact it will improve the regulation of the power supply.

A meter plugged into the keying jack should show about 20 mA. and, at the same time, the anode current of V2 will rise to 50 mA. or more.

No time should be lost in tuning C10 to the point where the anode current drops to a very low value. A small dip may be noticed at a low dial reading, at which point the circuit is tuned to the second harmonic. Further rotation will result in a pronounced dip. During this process, C12 should be set at minimum capacity and C13 at maximum.

The transmitter is then ready for use. Connect a good low resistance earth to the earth terminal and the aerial to the miniature stand-off insulator. From the latter, a short flexible lead terminating in a crocodile clip is used to tap on to the aerial coil. The tap will vary according to the length of aerial which may be anything from 30 to 200 feet—the higher the better. A long-wire aerial should be tapped near the earthy end of the coil, a short-wire aerial well up the coil.

On 1.8 Mc/s. the coupling condenser will be set at about one-third capacity—4 on the scale. Very rarely will more coupling be required and on the higher frequencies it will always be less. For instance, on 7 Mc/s. the coupling condenser should be set at zero, so that only the normal minimum capacity is effective.

On rotating C13 to resonance the anode current

of V2 will rise. If the rise and fall is sharp, the aerial is not matching-in properly and the tapping point should be increased. Conversely, if the rise and fall is sluggish, and of comparatively small amplitude, the tapping point should be reduced. The aim is to secure a smooth rise and fall, with the optimum meter reading such that the required input is obtained. This will be about 30 mA, on 1.8 Mc/s. and up to 50 mA., possibly at a greater H.T. voltage, on other frequencies.

Components List

1 Chassis, 8½" Panel and Pair Brackets	Cat. Nos. 617, 620 & 618	
2 Slow Motion Vernier Dials Silver Finish	
2 Microdensers 160pF (C10, C13) Cat. No. 637	
(but see text)	1131
1 Air Dielectric Trimmer Condenser 15pF (C12)	580
4 Stand-off Insulators	916
1 Miniature Stand-off Insulator	1019
3 Adjustable Insulated Brackets	1007
3 Large Flexible Couplers	50
1 Miniature Pointer Knob and Dial	425
1 R.F. Choke (RFC1)	1010
1 R.F. Choke Transmitting type (RFC2)	1022
1 Crystal and Holder (Type P.5)	Q.C.C.
1 Valve 6V6GT (V1)	Brimar
1 Valve EL37 (V2)	Mullard
1 Valve FW4/500 (V3)	Mullard
1 Valveholder British 4-pin.	
2 Valveholders Octal Ceramic.	
1 Mains Transformer Outputs 300-0-300 volts; 100mA; 6.3 v. 3 amps; 4 v. 3 amps	Woden
1 Smoothing Choke. 20 Henry 100mA	Woden
1 Panel Indicating Light	Bulgin
1 Fuseholder (Single) and 1 amp. Fuse type L.1045/C3	Belling Lee
2 D.P. Switches type S.88	Bulgin
1 Insulated Jack, Open Circuit type	Igranite
1 Moving Coil Meter type 0-50 mA (or 100 mA)	Howard Butler
7 Condensers Mica Moulded .002µF (C3, C4, C5, C6, C8, C9, C11)	Dubilier
1 Condenser Mica Moulded .01µF (C14)	Dubilier
2 Condensers Mica Moulded .002µF 1000 v. working (C17, C18)	Dubilier
1 Condenser Ceramic Cup 40pF (C2)	U.I.C.
2 Condensers Ceramic Cup 200pF (C1, C7)	U.I.C.
2 Condensers SaF Electrolytic 500v. working (C15, C16)	Dubilier
1 Resistor ½ watt 20 ohms (R3)	
1 Resistor 1 watt 6 ohms (R9)	
1 Resistor ½ watt 30,000 ohms (R1)	
1 Resistor 1 watt 200 ohms (R2)	
1 Resistor 2 watt 2000 ohms (R4)	
1 Resistor ½ watt 1000 ohms (R5)	Eric
1 Resistor ½ watt 20,000 ohms (R6)	
1 Resistor 3 watt 400 ohms (R7)	
1 Resistor ½ watt 100 ohms (R8)	
2 Resistors 5 watt 7500 ohms (R10, R12)	
1 Resistor 3 watt 1400 ohms (R11)	
Tag Strips, Rubber Grommets, 2, 4, and 6 B.A. Nuts and Bolts, Coil Formers, etc.	

Eddystone

Woden
Woden
BulginBelling Lee
Bulgin
Igranite

Howard Butler

Dubilier
DubilierDubilier
U.I.C.
U.I.C.

Dubilier

Eric

Eric

Eric

Eric

Eric

Keying

Keying is effected in the cathode circuit of V1. This valve is completely cut-off when the key is up and no harm will result if the transmitter is left switched on, with H.T. applied, for long periods. Keying of the original transmitter is smooth, but if any clicks become apparent, a condenser of 0.1µF capacity, 1,000 volts working and a resistor of 2,000 ohms may be connected in series across the key. For operation by remote control, a relay can be connected in place of the key.

The transmitter, as shown, is not suitable for telephony operation without small modifications. Chiefly, these consist of reducing the values of C8 and C11 and of altering the system of feeding the screen of V2 to enable simultaneous screen and anode modulation of this valve.

Continued on page 75

THE R1155 RECEIVER MODIFIED FOR AMATEUR USE

By A. H. MASON (GM6MS).*

NO doubt many R.A.F. type R1155 receivers have been purchased by members with a view to conversion for use on the amateur bands. In this short article an attempt will be made to describe the method used by the author in tackling the problem.

Clear out the D.F. Components

The first job is to remove all components which are unessential to the working of the receiver for communication purposes. This includes the B.F.O. box, the rear portion of which (containing the D.F. parts) is literally cut off with a pair of tin snips. After refitting the now much smaller box it will be found that there is sufficient space to accommodate an output transformer of normal size, as shown in Fig. 1. The double triode valve (type BL63) can then be brought into use as an output valve, with the two sections in parallel (as shown in Fig. 2) or push-pull. Alternatively another type, such as the 6V6, could be used.

The switching oscillator transformer fitted below the tuning indicator, can also be disconnected and removed.

As it was decided to dispense with ranges 4 and 5 (200 to 500 kc/s. and 75 to 200 kc/s.) the absence of the two large aerial coupling coils on top of the chassis left room for a mains transformer and smoothing choke. A rectifier can be fitted in place of one switching oscillator valve.

In order to gain space it will probably be necessary to cut down the functional switch to one wafer but this is quite satisfactory because the "Balance," "Visual" and "Figure of Eight" positions are not used.

A useful aid to improved band-spreading is to modify the condenser gang capacity by removing some of the vanes. This can be done by carefully working out the vanes with a pair of pliers. Halving the number of vanes in each section reduces the capacity to about $250\mu\text{F}$ which is a useful value.

It will be seen from Fig. 3 that the meter amplitude control has become a tone control, connected in series with a $0.01\mu\text{F}$ condenser across the output transformer primary. The meter deflection switch is replaced by a toggle switch connected in series with the centre-tap of the H.T. secondary on the mains transformer and this functions as a send-receive switch. The switching-oscillator speed switch is a mains control.

Whilst some constructors may prefer to retain the Jones plug connectors, the writer has a preference for jacks.

Re-arranging the R.F.

Having removed the comparatively low frequency ranges 4 and 5, the writer decided to elevate range 3 to range 5. This range includes the 1.7 to 2 Mc/s. amateur allocation. Range 2 coils are connected to the original range 4 positions and here again an amateur band (3.5 Mc/s.) is covered. To provide for range 3 the constructor must either rewind surplus coil formers from the old ranges 4 or 5, or make up a completely new set of coils of his own design to suit the 7 Mc/s. amateur band.

The original range 1 coils will be found on range 2 and here the 14 Mc/s. amateur band is spread out by suitable padding capacities.

Range 1 can be made to function on 28 Mc/s. using the remaining coil formers correctly wound, although

*390 King's Park Avenue, Rutherglen, Glasgow.

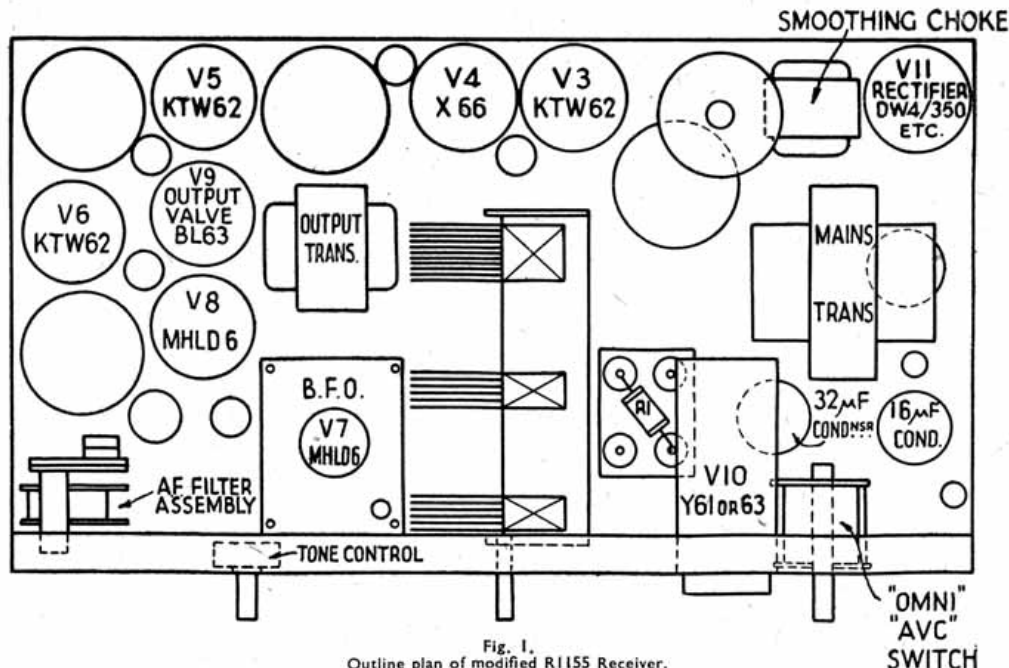

Fig. 1.
Outline plan of modified R1155 Receiver.

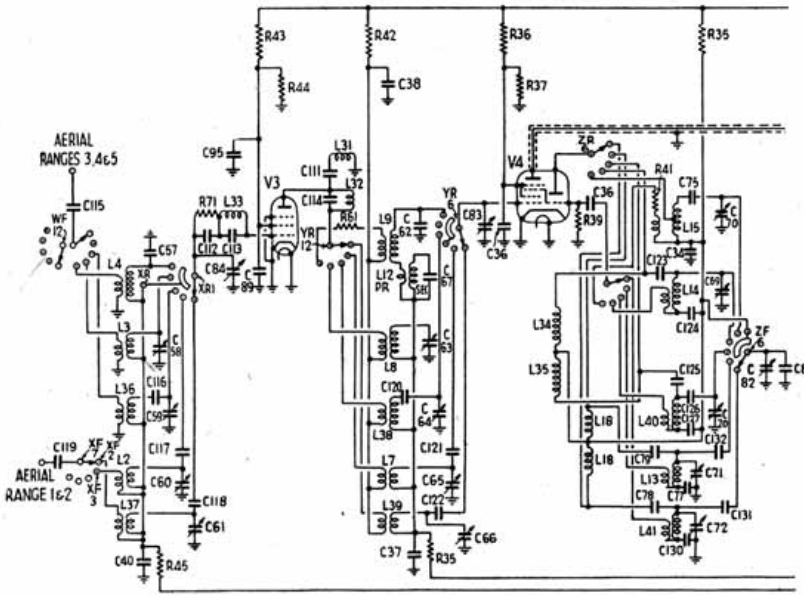
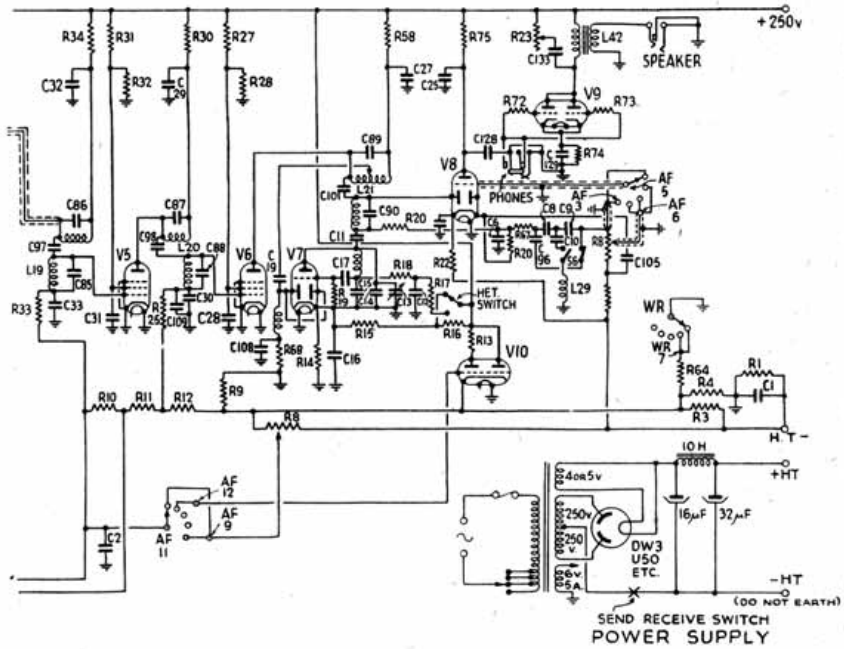

Fig. 2. Circuit of modified R1155 Receiver.



the practice is not to be recommended. It is better to wind self-supporting low-loss coils, the design for which must be worked out by the individual constructor as no details, regarding diameter, number of turns, etc., are available.

Power Supply

The normal H.T. current consumption of the R1155 is about 70 mA and this will be increased by another 25 to 35 mA according to the type of output valve used. An H.T. secondary winding capable of supplying 220 to 250 volts at 100 mA D.C. would be suitable. The smoothing arrangements illustrated have been found adequate, although smaller capacities with a

larger inductance choke would, no doubt, be in order. The difficulty lies in the limited amount of space available; a really big choke would not fit in.

Hints and Kinks

It is essential *not* to earth the H.T. negative as this will cut out the R.F. gain control. The value of R1 is also important as it affects the proper operation of this control. The voltage drop across R1 should be in the region of 30 to 42 volts and the original value of 2,000 ohms will be found to be too high. If the biasing resistor and condenser in the output stage are connected between the cathode and H.T. negative, R1 will require no alteration.

Before fitting the receiver casing it will be necessary to cut louvres or drill holes at the top right hand side, where the power pack is situated, in order to dissipate the heat. A series of holes should also be drilled along the back of the case at the bottom to allow an adequate influx of cold air.

The theoretical diagram, which is laid out in a similar manner to the official diagram but with the D.F. wiring omitted, should be of assistance to those who have obtained the standard circuit sheet.

It is realised that a great deal has been left to the amateur who is converting his R1155 and, perhaps, it is more fun that way. If there are, however, any points to be cleared up the author will do his best to supply the information.

The following is a list of components not originally fitted to the R1155 of which exact details can be given :

L34 and 35	Denco R.F. chokes Type R.F.C.5.
R72 and 73	1,000 ohms, .25 watt.
R74	500 ohms, .5 watt. (To suit BL63 valve.)
R75	.1 Megohm, .25 watt.
C115	500 μ F silvered mica condenser.
C117, 121, 132	300 μ F silvered mica condenser.
C119	100 μ F silvered mica condenser.
C123, 125	15 μ F ceramic condenser.
C124	1,670 μ F silvered mica condenser. (Originally C77, Range 2.)
C128	.01 μ F silvered mica condenser.
C129	25 μ F, 25 volts electrolytic condenser.

Note.—In the circuit diagram (Fig. 2) the lead from the right-hand side of C128 is shown connected to the 2nd instead of the 3rd spring of the 'phones jack, reading from the left.

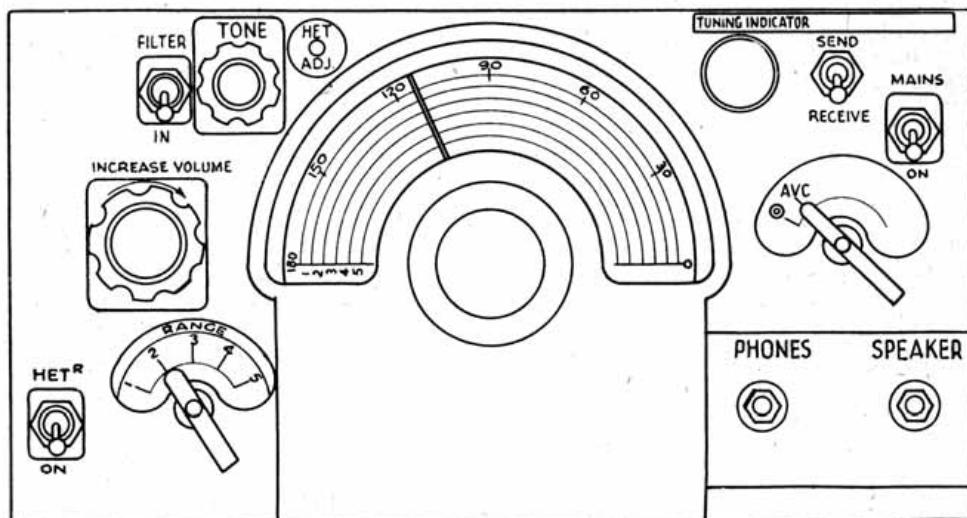

Fig. 3.
Front elevation of modified R1155 Receiver.

Remainder of 7 & 14 Mc/s Bands Released

As all members know the Society has, for months past, been pressing for the early release of the remainder of the 7 and 14 Mc/s. bands, in fact as far back as July we proposed that November 1, 1946, be set as the target date. In accordance with accepted practice this proposal was sent by the W/T Board to other administrations for their views. As recently as November 1 the G.P.O. Board informed the Society that whilst the W/T Board were prepared to authorise the release at once, other Governments had not signified agreement. Later, that day, the U.S. Government, through F.C.C., issued an order authorising the release of the remainder of the two bands.

It would seem that the U.S. Government, after rejecting the W/T Board suggestion and thereby causing other Administrations to follow suit, suddenly changed its mind without notifying other Governments.

We deeply deplore the inconvenience which has been caused but must emphasise once again that it was the R.S.G.B. that pressed for the release to take place on November 1, 1946.

After the fiasco created by the U.S. Government, the G.P.O. announced that both bands were released as from November 6th, 1946.

The R.S.G.B. Bulletin.

For some time past the Council has been considering ways and means for providing members with a larger BULLETIN, but unfortunately this is not possible at present owing to the enlarged circulation brought about by a greatly increased membership.

An alternative would be to produce a supplementary periodical and with this in mind the Secretary was requested to consult the Society's printers. The following is a copy of the report which he presented to the Council at its last meeting :

"I have discussed with our printers the suggestion that the Society should produce a new periodical, and am advised that for a circulation of 15,000 copies, the size would be 8 pp. and 4 pp. covers for a quarterly or 12 pp. without covers. If publication was made every 4 months the size could be increased to 12 pp. and 4 pp. covers, or 16 pp. without covers. The Paper Order dealing with new publications states clearly that the weight of paper used for a new publication must not exceed 8 cwt. in any 4 monthly period."

In view of this information the Council resolved that no useful purpose would be served by attempting to produce a second publication at present.

The Council much regrets that the Society is being penalised because its membership has increased.

UTILITY AMPLIFIER

By G. MICHAEL KING, B.Sc. (G3MY)*

THE amplifier to be described was built up from odd components found around the "shack." As electrolytics are, at present, difficult to obtain, a single 8 μ F 500 volts condenser was used across the rectifier and the output valves fed directly from this point. No smoothing choke is employed.

The mains transformer was made up from a 350-0-350 volts 90 mA replacement bobbin, with an old core fitted. The output is about 375 volts at 100 mA.

The output valves are 6B5's, as these happened to be available, but if 6N6's had been used, then by suitable adjustment to the bias supply, 6F6's, 6K6's, or 6L6's could be plugged into the sockets without further circuit changes. In the case of the 6B5's in current use one draws 42 mA and the other 40 mA plate current so that the hum which would be caused by the scanty smoothing is almost completely balanced out in the output transformer. The latter was home-wound on an old mains transformer core and is

early stages is achieved by means of a series of 5,000 ohms resistances and 2 μ F condensers of the 250 volts Mansbridge type. This method of smoothing has proved remarkably effective and very little hum is present even at full gain. There is no instability or "motor-boating" with the gain control wide open.

The gain through all three stages is more than adequate for a diaphragm-type crystal microphone.

Gramophone or radio output is fed into a jack in the grid of the 6C5 stage, which cuts out the 6J7 stage.

Results have exceeded all expectations and when used after a 14-valve home-constructed double super, the quality of reproduction on American and other short-wave stations leaves nothing to be desired.

For local station reception, a simple tuner, consisting of a 6K7 R.F. and a 6C5 infinite impedance detector, is used. The output from this unit is fed into the 6C5 stage of the amplifier and excellent quality is produced.

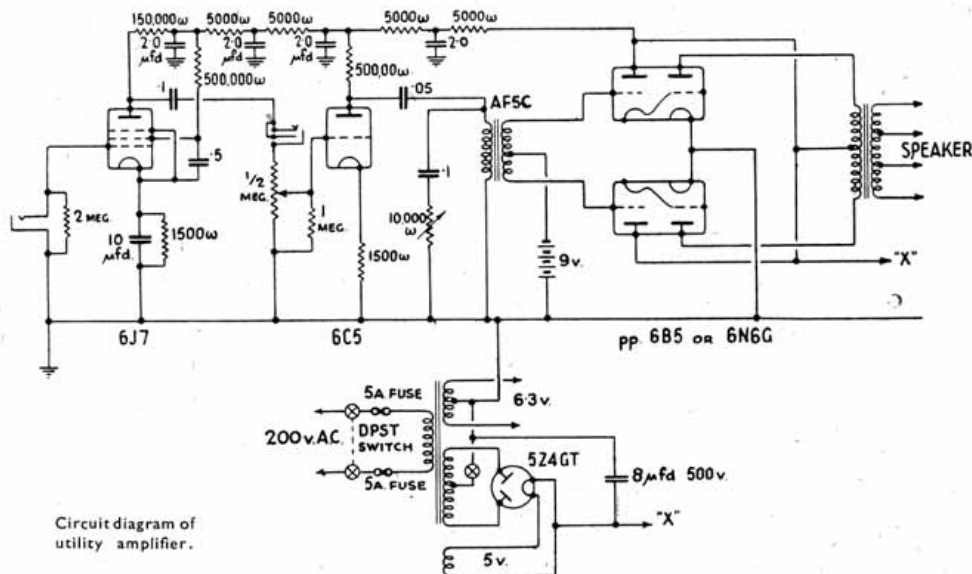

Circuit diagram of utility amplifier.

designed to match a 10,000 ohms push-pull load to a 7 or 15 ohms speaker. The "no-load" primary inductance is in the region of 60 henrys giving a good low-frequency response.

The output valves are driven by an AF5C, but equally good results would have been obtained by using an ordinary 3-1 step-up transformer and auto-tapping the secondary by means of two 0.5 megohms resistances. This is feasible so long as the output valves are not driven into the grid current region. This condition might happen with 6F6's or 6L6's but cannot occur with 6B5's.

The inter-valve transformer is parallel fed from a 6C5, and the tone control (consisting of a 0.1 μ F condenser and a 10,000 ohms potentiometer) is connected across the primary of this transformer. The volume control is in the grid circuit of the 6C5 which is biased by means of a 1,500 ohms resistance, not bi-passed.

The first stage is a 6J7 connected in a perfectly conventional circuit.

As can be seen from the diagram, smoothing for the

London Region Meeting.

There was an attendance of nearly 250 members at the first meeting of the autumn session held on Friday, October 18, at the Institution of Electrical Engineers, when Messrs. Denis Heightman, G6DH and E. J. Williams, B.Sc., G2XC, delivered a joint paper on 60 Mc/s. propagation conditions, and Mr. W. A. Scarr, M.A., G2WS, a paper dealing with 60 Mc/s. field day work. The papers will be published in early issues of THE BULLETIN. A vote of thanks to the speakers was proposed by Mr. Austin Forsyth, O.B.E., G6FO.

The following members contributed to the ensuing discussion: Messrs. H. A. M. Clark, G6OT, D. N. Corfield, G5CD, J. Rockall, M.B.E., G2ZV, W. J. Butler, G5LJ, C. Young, G2AK, M. D. Mason, G6VX and A. J. Hallett, G3CQ.

At the end of the meeting Mr. Scarr displayed examples of portable 60 Mc/s. gear.

Mr. S. K. Lewer, B.Sc., G6LJ (Executive Vice-President), was in the Chair.

*51, Springfield Road, Sheffield, 7

IDLE FREQUENCIES

PART I

By B. W. F. MAINPRISE, B.Sc. (Eng.); A.M.I.E.E. (G5MP)

An analysis of certain non-amateur bands, showing that the present small number of stations occupying them is unlikely to increase.

WAR is the greatest developer of radio frequencies and commercial rivalry takes second place to it. Consequently the present time—a year or so after the conclusion of actual hostilities in World War II—suggests an appropriate occasion for examining past and future occupancy of the normal radio-frequency spectrum, and pausing over any bands which may lie unwanted or derelict.

Suppose we work our way up from the lowest frequencies. We will refer to frequency allocations in very round numbers, because many bands are subdivided and shared. For a closer examination of band limits the writer would refer members to the very useful chart published by *Webb's Radio* on the back cover of the June, 1943, issue of the R.S.G.B. BULLETIN, where the bands are clearly set out in colours and the only minor point of criticism is the large scale given to the lower frequencies.

Starting then at the bottom, we can say that from approximately 10 to 130 kc/s. we have high power fixed stations, and also the long-wave marine traffic. From 130 to 250 kc/s. the long-wave broadcasters, sharing with other services. From 250 to 400 kc/s., aeronautical services. Incidentally, it is of interest to remember that in coming from 10 to 400 kc/s. we have passed through a band of less width than our 14 Mc/s. band; in fact we will use the 14 Mc/s. band as a standard of comparison later in this analysis.

Still moving upwards, we find the marine traffic band from 400 to 550 kc/s., well congested in the waters around our British Isles, which protect the approaches to Northern and North-Western Europe. What magnificent jamming there used to be on this band even 10 years ago, when spark was the reigning monarch! Next, the broadcast band, with the medium wave broadcasters—sole tenants of the band—operating in an orderly array of channels, a model of planning and attention to frequency stability. From 1500 to 2000 kc/s. are the small fixed and mobile services—lightships, coastal shipping stations—our 1.7 Mc/s. band—fishing vessels whose carriers in many cases explode under the stress of modulation and descend in fragments over surrounding frequencies. A moderately busy band, but one whose occupancy would be very much reduced by a clean-up of the lowest quality telephony and the curtailment of the general supply of harmonics from the 400–550 kc/s. marine band.

Next we come to the region 2000 to 3500 kc/s. and here we must pause to examine the occupants in severer detail. First we notice numerous weak carriers bearing the light modulation characteristic of their parents the medium wave broadcasters. Like all harmonics they are radiated in violation of international regulations, but with a fundamental power of 50,000 watts one must perhaps in fairness turn a deaf ear to the presence of some 10 watts or so of second harmonic. Two or three police transmissions. Half-a-dozen—or in times of frantic activity—a dozen Service mobile transmissions, spread over a band 1500 kc/s. wide: in other words a band as wide as that covering the long wave, medium wave, and shipping and aeronautical bands all put end to end.

At the time this article was being written two occupancy checks were taken and the results are given below:—

1830 hrs., August 18. Not a single station (apart

from broadcast harmonics) between 2.4 and 2.8 Mc/s. Three stations between 2.8 and 3.2 Mc/s.

Noon, August 19. Two stations between 2.4 and 2.8 Mc/s. Two stations between 2.8 and 3.2 Mc/s.

A further check taken shortly before publication of this article gave the following figures:—

Noon, October 20. Not a single station between 2.4 and 2.8 Mc/s. One station between 2.8 and 3.2 Mc/s. In comparison 27 stations (which includes, however, some harmonics) were operating between 3.5 and 3.8 Mc/s., a band considerably narrower than either of the above.

1015 hrs., October 24. Three stations between 2.4 and 2.8 Mc/s. Five stations between 2.8 and 3.2 Mc/s.

Previous checks have shown similar results for a long time past. The receiver was a 9-valve Hallicrafter with the gain turned well above the usual setting for operation in the 1.8 Mc/s. band. In each case it will be noted that a 400 kc/s. band was chosen, giving an equal number of kilocycles to our 14 Mc/s. band, and a 33 per cent. wider coverage than our 7 Mc/s. band.

Is occupancy likely to increase? First we must remember that many Service transmissions such as ground-to-air, artillery direction and so on, have abandoned this region of the frequency spectrum in favour of the V.H.F.'s, as the lower frequencies required inconveniently long aerials, offered no secrecy, and provided a background of high noise level and static, especially in lower latitudes than ours. By moving to the V.H.F.'s the Services were able to employ compact aerials giving better radiation, often in a beam when required, with consequent improvement in secrecy. The transmissions could be restricted more to the points and distances required without straying excessively afield. Static was non-existent and background noise appreciably lower. A much wider range of frequencies became available, enabling networks to be set further apart without interfering with others. Consequently the Services are very unlikely to return to frequencies below 3500 kc/s., and even a five-fold increase in activity (which is hardly probable) would still leave many deserted kilocycles. The broadcasters have never claimed this region, for few domestic receivers will tune to it. There is little sign of navigational aids requiring it.

At this point it might be advisable to stress that this article should not be taken to suggest that we be allocated frequencies in this sparsely occupied region, now that our 1.7 and 3.5 Mc/s. bands have been restored. In view, however, of the rapid rise of R.S.G.B. membership from the pre-war figure of 3,000 to the present figure of 12,000, it is reasonable to assume that the curve of licenced transmitting operators will follow a similar tendency, with a time lag of a year or so, rendering the examination of frequency allocations imperative from time to time. In the concluding instalment an analysis will be made of certain other non-amateur frequency bands at present mainly unoccupied and in which little increase of occupancy seems likely in view of the development of the V.H.F.'s.

(To be concluded.)

TOP BAND CONTEST

November 30th—December 1st, 1946

THE Contests Committee, with the approval of the Council, have arranged to organise a "top band" telegraphy contest during the week-end November 30—December 1, 1946. The Rules for this contest follow closely on the lines of pre-war 1.75 Mc/s. Contests except that on this occasion there will be a break period of six hours between 1000 G.M.T. and 1600 G.M.T. on the Sunday.

It is hoped that telephony operators who normally use this band will co-operate by restricting their transmissions as much as possible during the hours of the Contest.

Competitors are recommended to use "break-in" where possible and to make their CQ and answering calls brief. Time will also be saved if the new Q code signals QLM, QHM, etc. (as published in the September, 1946, issue of THE BULLETIN) are adopted.

Competitors are urged to keep a careful check on the frequencies used for their transmissions, and to avoid causing interference with Loran and other Government services.

Particular care should be exercised in making out entry forms as inaccuracies in this direction may lead to a loss of points. The Committee urge all those who take part in the Contest to forward an entry, whatever their score, as their logs will prove of great value when the returns are checked. The submission of reception logs is invited for the same reason.

Finally please do not make pre-arranged schedules.

Rules

(1) The Contest is open to all fully paid-up members of the Society resident within the British Isles.

(2) The British Isles for the purposes of this Contest includes England (G), Scotland (GM), Northern Ireland (GI) Wales (GW), Channel Islands (GC) and Eire (EI).

(3) The Contest will commence at 2200 G.M.T. Saturday, November 30, 1946, and will conclude at 2200 G.M.T., Sunday, December 1, 1946, with a break of six hours between 1000 G.M.T. and 1600 G.M.T. on the Sunday.

(4) Entries will be accepted only if submitted on lined foolscap or quarto paper and in the form set out below:—

1.75 Mc/s. Contest, 1946

Name.....
 Address.....
 Call Sign.....
 Details of Equipment & Aerials used.....

Contact No.	Date	G.M.T.	Call of Station Worked	Outgoing Report R.S.T.	Incoming Report R.S.T.

DECLARATION.—*I declare that my station was operated strictly in accordance with the rules and spirit of the Contest and I agree that the ruling of the Council of the R.S.G.B. shall be final in all cases of dispute.*

Signed.....

(5) No entry form will be accepted if received after Monday, December 9, 1946.

(6) Details at the top of the entry form must be completely filled in and the declaration signed, otherwise the entry will be disqualified.

(7) Entries must be addressed to the Honorary Secretary, R.S.G.B. Contests Committee, 56 Jubilee Drive, South Ruislip, Middlesex, and *not* to Headquarters

(8) Proof of contact may be required.

(9) Contacts with, or calls from, ship or unlicensed stations, will not be permitted to count for points.

(10) The Contest is confined to two-way telegraphy contacts only.

(11) Only one person will be permitted to operate a specific station during the Contest.

(12) An exchange of R.S.T. reports will be required before points for a contact can be claimed.

(13) Only one contact with a specific station will be permitted to count for points during the Contest.

(14) One point will be scored for each contact.

(15) The input power to the final amplifier of the transmitter must not exceed ten watts nor may this figure be exceeded on any previous stage.

(16) Leading competitors will be awarded Certificates of Merit, whilst a trophy may be awarded at the discretion of the Council.

(17) The Council have the right to amend or alter these rules at any time prior to the commencement of the Contest, and their decision will be final in all cases of dispute.

Calibration Service.

The Council has received and accepted offers from Messrs. Pill, G5CX, Dorman, G3ABP, Wingfield, G2AO and Ransom, G5XA to give frequency checks over the air. Members will appreciate that, whilst the Council has taken every precaution to ensure that suitably qualified members have been selected to operate this service, the Society cannot guarantee the accuracy of the information thus provided.

Mr. Doley, BR54679, of Pelham House, Norham-on-Tweed, has offered to check the frequency of any transmission on request.

TOP-BAND TWO TRANSMITTER (contd. from page 69).

Minor Modifications

In some instances the constructor may wish to vary the construction somewhat. The slow motion dials are a definite help when tuning the transmitter, but direct drive dials may be substituted.

The moving coil milliammeter which is shown permanently wired in the anode circuit of the P.A. valve is very necessary when tuning-up but, of course, an external meter may be employed. If desired, an insulated closed circuit jack may be fitted at either the front or rear of the chassis.

If the transmitter is required mainly for use on Reserve frequencies, it would be well to change the values of C10 and C13 to 100pF. If 7 Mc/s. should be the main interest, a further reduction to 60pF. will render tuning easier on this band.

When experience of tuning the transmitter has been gained, the value of the cathode resistor R7 may be reduced to 200 or 250 ohms. A slight increase of both input and output is probable but the optimum value of resistance is bound up with the type of valve employed in the P.A. stage.

THE MONTH ON THE AIR

By A. O. MILNE, (G2MI) *

ALTHOUGH, so far we are not permitted to use the eleven metre band, quite a number of U.S. stations call CQ there and listen on "Ten." It often happens that signals on this band are louder than those on 28 Mc/s. and it also happens that W2's for example, still come through on 27 Mc/s. when they are fading out on 28 Mc/s. It is possible, with two aeriels, to listen through on 27 Mc/s. whilst transmitting on 28 Mc/s. and it is therefore quite a good idea to call CQ and intimate that you are listening for replies on the 27 Mc/s. band, at the same time inviting stations to break-in and call. The Americans are allowed to use duplex telephony on 27 Mc/s. so the band offers the chance of a duplex 'phone QSO with the States.

Many American stations complain that we do not listen in the 29 Mc/s. portion of the band. Again, it is a good idea to use a high frequency crystal and establish a few QRM-free contacts, even if it does take a little longer. Try it some time.

Notes & News

G3CO gives us these nice ones to chase. J2AAF Tokio, 14130. W6JIM/C1, 14135, A.P.O. 908 c/o Postmaster, San Francisco. EL5B, Jesse Bell, A.P.O. 605, Miami or A.P.O. 524, N.Y.C. VSTES is located at 5 Elbank Road, Havelocktown, Colombo, Ceylon. VU2AC is the pre-war VU2CQ.

G6ZO, who got in just too late for publication last month, has the usual list of good things. W6VKV/16 is U.S. Army Radio Station, A.P.O. 843, c/o Postmaster, N.Y.C. Cards have arrived at the Bureau from this station. British Army personnel in Eritrea are still vainly trying to persuade the local Military to give out some licences! C7LP on 14105 is Box 150, Peiping, China. EKIAZ is Box 45, British Post Office, Tangier. A large wad of cards has recently arrived from this station. EA9AI also QSL's.

A few frequencies to watch are 14035, ZP6AB; 14130, YS1BK; 14160, YS1X; 14100 and 14115, W3GZT/J9 on Okinawa; 14075, XABU, Rhodes; 14125, W6UDF/KG6. FMS8C has just come through with a batch of cards. His QTH is Robert Martinon, Box 260, Fort de France, Martinique, French West Indies. W2LFI/FG3FP on 14070 and 14165 is at Pan American Airlines, Dakar. FWA, A.P.O. 622, c/o Postmaster, Miami, Florida.

EL3A, 14075, goes c/o Vice Consul Monrovia, Liberia.

VR5BY is a pirate. ZL's and VK's say he definitely is not in that part of the world. One or two other good 'uns are W2CZ/KL7, 14165; ZD8A (not yet established as genuine) 14035; UA6LC, 14130 Rostov; UB5AL, 14130 Borislav; UO5VW, 14130 at Kagul, Box 456. This was Rumanian territory prior to the war. J4AAB is on 14110 and VP8AD also. VP4TB 14105 is Bob Wilson, 61 Mucurapo Road, Port of Spain, Trinidad. Y16C is on 14070, QSL to H.Q. British Forces in Iraq. VS1BX says CR9AN is Adrian Rosario, CTTC, Macau on 14018. J3HRP is in Kyoto, 14090. EZ4X is in the Saar, QSL via HB9CE. No information as to his status. HC1XC claims to be in the Galapagos Is. G6BY says that FA8JD is W9MTV and is now back in the States. Will QSL 100 per cent.

G5WP gives these as his contribution: PZ1A, 28625, Box 679 Paramaribo Surinam; KH6AR (old K6MUV), 28950; KH6FD (old K6ROJ), 28975. Note the frequencies? VR2AB, 28456, VR2AC, 28400

and VR2AF 28320, can all be contacted via Box 338, Suva, Fiji. All on, phone. G5WP has worked VR2AB. Is this the first G-VR2, 'phone QSO?

BRS7765 on Rodrigues Island is trying to get a licence. Things are rather slow in maturing, however, due to a somewhat sketchy steamer service. He has heard G2PU, G3FA, G5YA and G3BM. G8LO informs us that W2MMO is on a ship in the Red Sea. He uses 'phone, C.W. and L.C.W. BRS gives VS9AB as Station Engineer, A.M.W.D., R.A.F. Station, Khormaksar, Aden. YP1AA is said to be on a Rumanian ship in the Black Sea and asks for cards to be sent to Messrs. Ashman, The Minerva Club, 28A Brunswick Square, W.C.1. This comes via G6WX.

ZD4AB hopes soon to QRO from 10 to 50 watts. G8CI notes that W9CAC/TF is on 14180 kc/s. QSL via American Overseas Airways, A.P.O. 610, N.Y.C. G3AAR has contacted UN1AO, who is at Petrozavodsk on Lake Onega, 14090.

Sardinia

XACP is glad to reply to BRS cards and points out that Service Mails are free and that he has a willing and efficient "QSL Dept." Consequently those thoughtful souls who send him Reply Coupons are wasting their hard earned sixpences.

W.I.A. Contest

The W.I.A. (Australia) DX Contest is being run from 1700 G.M.T. on November 2 to 1700 G.M.T. on November 3 and the same times on November 9 and 10. A serial number and RST reports must be exchanged with each Australian Station worked. Each participant will allot himself three figures. These form the first half of the serial number. The other half at the first QSO will be 000. This he passes to his contact, receiving in exchange, say, 635000. For his next contact he drops the 000 and adds the first three figures from this received number to form the number sent to the next station and so on.

Closing date is January 31, 1947, and entries must be addressed to Wireless Institute of Australia, 191 Queen Street, Melbourne, C.1.

Pacusan Dreamboat

The recent flight of the Super Fortress "Pacusan Dreamboat" provided a thrill for the few lucky ones to work him. So far as we know the honour of being the first G station to make contact goes to G8KP of Sheffield. The "Dreamboat" was on 14300 kc/s. telephony. Other stations to make QSO were G8IG, GM2UU and a D4, just as the plane made landfall off Alexandria. These latter contacts provided a very distasteful exhibition of bad manners on the part of certain South London stations who swooped on to the frequency given by G8IG, with their V.F.O.'s and effectively blotted out the station for whom G8IG had asked the operator of the "Dreamboat" to listen. Much good it did them except to once again publicly advertise their type of mind!

Japan

A letter from our old friend Drudge-Coates, J4AAC, brings the news that our boys in Japan are now coming on the air in a big way. The country has been zoned and straight calls are being allotted. Such calls as W2BU/J2 are definitely "out." All British, Australian, New Zealand and U.S. Army amateurs will come into line. The Districts are as follows:—

J2, Central Honshu. J3, S.W. Honshu. J4, S. Honshu and Shikoku. (British, Australian and N.Z. Army.) J5, Kyushu. J6, N. Honshu. J7, Hokkaido. J8, Korea. J9, Okinawa. QSL via R.S.G.B.

* 29 Kechill Gardens, Bromley, Kent.

VESMJ

This station is located at a Hudson Bay post on Baffin Is. and enjoys one delivery and collection of mail per year. Cards have just arrived at the Bureau. He has been using a 6L7 oscillator to drive a single 6L6. The aerial was a half wave, centre fed. The power pack consists of a vibra-pack giving 300 volts, 100 MA. The annual supply ship has by now delivered some new gear and VESMJ should soon be better equipped. G6CL has received some excellent photos of the operator and his station which it is hoped to publish shortly.

Manchester P.D.M. A Record Breaker.

THE District 1 P.D.M. held at Belle Vue Gardens, Manchester, on Sunday, October 13, broke all attendance records for an R.S.G.B. provincial event—no less than 190 members being present. Headquarters was represented by the President (G6GR), G8KZ, G8TL, G2DP and the General Secretary (G6CL). An excellent lunch preceded the meeting which was opened by the D.R., Mr. H. W. Stacey (G6CX), who expressed his pleasure at seeing such a large and enthusiastic gathering. At the request of the President all present stood in silence to pay a tribute to those members who made the supreme sacrifice during the war. Mr. Gardiner then explained the purpose of a P.D.M. pointing out that such meetings were arranged to bring together in closer friendship all those who were keenly interested in Amateur Radio. He also dealt briefly with representation and appealed to members to show an active interest in voting, particularly with regard to the election of T.R.'s.

The General Secretary then took over and for more than an hour his speech was listened to with the keenest interest and for which he received great applause. He related how, since the cessation of hostilities, the Council had worked to obtain improved licence facilities and that as a result we were, at present, in possession of practically the whole of the bands that existed in 1939. He was very hopeful that in the near future other bands would be released. With regard to the smallness in size of THE BULL, he stated that this was entirely due to paper rationing coupled with increased circulation and that the allocation of paper to the Society was not sufficient to print larger issues at the moment. Mr. Clarricoats dealt at some length with representation and the status of affiliated societies after which members were asked to submit questions. These were ably answered by the General Secretary.

During tea a "raffle" took place for components donated by the following manufacturers who also exhibited their products: Messrs Stratton & Co., Ltd., Labgear Ltd. and Salford Electrical Instruments Ltd. These exhibits proved a source of great interest and thanks are extended to the firms concerned for their co-operation in helping to make the P.D.M. such a great success and for their kindness in donating components. G4ND.

Model Control Group.

Membership is now 58 and a complete list of the names and addresses of members will be issued with the fifth budget due to be issued in mid November. Will all members who have missed any of the budgets please advise F./Lt. J. O. Dykes not later than the end of November.

Fourteen copies of the budget are now being issued; approximately one per four members so that everyone should see each budget fairly soon after publication.

Silent Key

Seymour Buckingham, G5QF

IT is our sad duty to record the passing of one who provided a shining example of the true spirit of Amateur Radio. Seymour Buckingham—District 12 Representative of the Society since 1932—was held in high esteem by members in all parts of the country. In his own District of North London and Hertfordshire that esteem changed to a warmth of affection as the Dark Shadow loomed nearer.

"Buck," as he was known to most of us, joined the Society in 1926. His outstanding ability in the constructional field quickly earned for him the praise of many who had up to that time given little thought to the outward appearance of their stations. His numerous contributions to the Society's Journal won for him, in 1938, the highly coveted "Wortley Talbot" Trophy.

In 1932 he succeeded G6CL as North London Representative and throughout the years that followed he carried out his duties with a zeal and enthusiasm that will be difficult to surpass.

A serious illness during the first years of the war did nothing to deter him from his self-imposed task of keeping his District together. From his sick bed he maintained contact with his friends at home and abroad and every week he received letters of encouragement from those who valued his friendship. After a long uphill fight he eventually returned to London, but he was not content to sit idly at home. "Buck" was asked to undertake a certain duty, onerous in the extreme. For long hours he gave of his all with his receiver beside him. There are many members who have personal knowledge of the work he did during the last three years of the war.

Few who knew him were aware that in his youth he had served in the Brigade of Guards. It was that training, no doubt, which enabled him to fight ill-health and to serve his country again in time of need.

Of his work as D.R. much could be written but it is sufficient to say that no member of the Society was held in higher regard by the President, Council and Headquarters Staff. Every member of the present Council knew him personally and cherished his friendship. Most of our D.R.'s knew him and respected his knowledge of Society work. Hundreds of members knew him and turned to him for guidance and help. "Buck" was generous to the last degree, sincere, hospitable, kind and a grand "ham." By his passing the Society has lost one of its staunchest supporters and the writer of this last tribute a very close friend and companion.

On behalf of the membership we offer to Mrs. Buckingham and to her three children our heartfelt sympathies. May they take comfort in the knowledge that the name of Seymour Buckingham will remain fresh in the memory of his countless friends for years to come.

The funeral took place at St. Marylebone Crematorium, Finchley, on Thursday, October 24. Those present included Mr. H. A. M. Clark and Mr. P. C. G. Bradley (representing the President and Council), Mr. S. Howard, Mr. W. E. Bridgen and Mr. R. Stevens (representing District 12), Mr. H. V. Wilkins (representing District 15), Mr. and Mrs. John Clarricoats and Miss May Gadsden.

J. C.

THE MONTH ON FIVE

By W. A. SCARR, M.A. (G2WS)

THE second and third weeks in October gave us a very welcome and quite unexpected period of first-rate conditions on the band, and it was a pleasure to hear so many signals during the evenings. At the close of this fortnight, members in the London area had the privilege of listening to a fine exposition of 60 Mc/s, propagation by Ted Williams (G2XC) and Denis Heightman (G6DH) based on daily observations made during the last six months.

This lecture could not have been better timed for it gave a complete explanation of the DX achievements of the previous fortnight. The weather during this time remained calm and overcast. Temperatures were generally low but apparently a sharp humidity gradient was set-up above the cloud layer and this acted as an efficient refracting medium. The lecturers showed that at certain heights, humidity variations are more effective than temperature changes in producing refractions.

The factor that made this fortnight perhaps the best period of the year was the absolute steadiness of DX signals. Stations over 100 miles distant could be contacted and QSO's completed without a trace of fading. This is in sharp contrast to the "up and down" nature of most of the inter-G DX contacts made in the summer.

There are several reports this month of new 5-metre developments abroad. Ken Ellis (SUIKE) announces that an auto-keyed transmitter is operating from the Near East on 58-68 Mc/s. Any reception of this station, which is operating under various call-signs, should be reported immediately. Another member, Mr. Stace of Faversham, is being licensed to operate in Austria where he is now stationed. He is hoping to operate a 5-metre transmitter from 6,300

feet above sea-level. HASS of Budapest states in a letter to BRS5360 that HA stations are anxious to co-operate in 56 Mc/s. tests.

G3CQ (Havering-atte-Bower) sends an interesting description of his 5-metre rig. The final stage of the transmitter is a 35T acting as a power-doubler. 100 ohm twin coaxial cable feeds a 4-element horizontal array 23 feet above ground. About 400 yards to the North of the aerial a hill rises to a hundred feet, nevertheless 3 CQ managed to work G2AK (Birmingham) during good conditions in September. Does this hill also account for the great strength of 3 CQ's signals in the South?

G5JU has moved into Birmingham and is active at the new QRA. The transmitter uses a QV04/20 in the final. A fixed dipole is being used for the time being but many good contacts were made during the good spell in October. A rotary beam is soon to be erected.

G3BY (Aston-u-Lyne) gets astonishing results from a three-element beam hung from the ceiling of an upstairs room. Recent QSO's have been with G2MR (Surbiton), G2XC (Portsmouth), G5MA (Surrey) and G5TX (Isle of Wight). August 22 brought a contact with F8PU and the hiss phenomenon was noticed on September 26.

G6US (Oswestry) complains that modulated oscillators in his area are ruining any chance of hearing DX on the band. There is little excuse for this kind of interference nowadays.

G5IG (Cambridge) is stirring up interest in "five" in the area and several new stations will soon be on the air. 5IG is maintaining contact with G2MR, G2WS, G2XC, G5TX, G6DH, G6LK, G6VX, G6YU and others. He blames the local gas-works (in a direct line) for the difficulty experienced in working G6DH at Clacton.

INCORPORATED RADIO SOCIETY OF GREAT BRITAIN

NEW RUSKIN HOUSE, LITTLE RUSSELL STREET
LONDON, W.C.1

Technical Manager

APPLICATIONS are invited for the above appointment on the Headquarters' staff of the Society.

The duties of the Technical Manager will include the design of amateur radio equipment and technical editorial work.

Applicants should possess the under-mentioned qualifications:—

- Considerable experience as a practicing amateur, preferably well known in the Society.
- Sound theoretical knowledge of radio and allied subjects.
- Good editorial ability.
- Experience in the design and construction of receivers and transmitters, preferably obtained in a professional capacity.

Commencing salary £500 per annum, or higher, according to qualifications.

Applications, giving particulars of education, qualifications and experience and containing the names of two persons to whom references may be made as to the candidate's character and ability, should be sent to the undersigned not later than 16th December, 1946.

Candidates canvassing members of the Council directly or indirectly will be disqualified.

JOHN CLARRICOATS,

15th November, 1946.

General Secretary.

INCORPORATED RADIO SOCIETY OF GREAT BRITAIN

NEW RUSKIN HOUSE, LITTLE RUSSELL STREET
LONDON, W.C.1

Assistant to the General Secretary

APPLICATIONS are invited from keen young members for the above appointment on the Headquarters' staff of the Society. The under-mentioned qualifications will be taken into consideration in the selection of an applicant:—

- Experience as an active amateur, preferably one well-known in the Society.
- Sound general knowledge of office routine including some knowledge of book-keeping.
- Ability to address meetings of Society members and to entertain visitors.

Preference may be given to an applicant who is able to type at a reasonable speed, but this is not a necessary qualification.

The successful applicant will act as an Assistant to the General Secretary, and may be required to travel on behalf of the Society.

Commencing salary £200-£300 per annum.

Applications, in candidate's own handwriting, giving particulars of education, qualifications and experience and containing the names of two persons to whom references may be made as to the candidate's character and ability, should be sent to the undersigned not later than 16th December, 1946.

Candidates canvassing members of the Council directly or indirectly will be disqualified.

JOHN CLARRICOATS,

15th November, 1946.

General Secretary.

Six Months on the Top Band.

By K. T. HARVEY (G5KT)

FROM the middle of March when the "top band" was first released, a record has been kept at G5KT of all U.K. stations heard. Up to the middle of September the total had reached 558, but it is known that many others have been active.

The standard of operating has been good and no station has been heard off frequency. Interference from trawler stations has not been severe probably because they are operating on frequencies lower than 1.8 Mc/s. A fairly large number of three letter G2 and G3 stations have been logged and in nearly every instance their operating procedure has been excellent.

Admiralty Electronic Scrap Scheme.

Acting upon advice from the Council, the Admiralty has cancelled the scheme whereby members have been privileged to purchase electronic scrap at 50s. per cwt. The Council regrets that the scheme has been abused in certain quarters.

It is apparent, however, that full use is still not being made of the band. Stations employing crystals between 1925 and 2000 kc/s have frequently been heard calling CQ without obtaining replies with the result that they have been obliged to move to the low frequency end thus adding to the QRM. The release of frequencies between 1715 and 1800 kc/s should ease this problem but the writer has found during recent weeks that many operators appear to forget to tune over this part of the band after a CQ call.

During the past three months, activity has fallen off a little due to the opening up of 7 and 14 Mc/s, and later 3.5 Mc/s, but it seems clear that the coming winter will see a big increase in top band operation.

The following is an analysis of all U.K. stations logged to date:—G2, 175; G3, 77; G4, 36; G5, 86; G6, 90; G8, 57; GC, 2; GI, 5; GM, 15; GW, 15.

In addition numerous D2 and D4 stations have been logged, as well as OZ1W, G5HB/F (near Paris) and G6HB/I (Rome) all of whom were worked from G5KT. XON4AA (a Belgium yacht) has also been logged on 1.7 Mc/s and worked on 3.5 Mc/s.

It is hoped that this brief report of post-war activity on 1.7 Mc/s may be of interest to those who use the band and that it will whet the appetites of many others in time for the forthcoming Top Band Contest.

EXCHANGE AND MART SECTION

Due to paper restrictions advertisements are only accepted "for insertion when space is available." No advertisement must exceed 50 words. **RATES: Members Private Advertisements 2d. per word, minimum charge 3/-. Trade, 6d. per word, minimum charge 9/-. Send copy and payment to PARRS Advertising, 121 Kingsway, London, W.C.2.**

A good price paid for S.W. News, January. Odd copies *Radio Craft, Radio and Television*, 1939-1945. *QST*, complete 1939-1946. Also Hallcrafters SX28A and S36A mains type button base valves.—BRS13053, 16 Lugley Street, Newport, Isle of Wight.

ALBERT PARKER (G3KH) wishes to contact Len Herrington, Pat Wodehouse and R.A.F. friends.—61 Main Street, Kirby Muxloe, Leicestershire.

MATEUR Radio Service G6HP. Eddystone, Raymart, Hamrad, Radio-Aid agents. For any metal work, components, complete equipment. Prompt efficient Mail Order Service S.A.E. new comprehensive lists.—G6HP, Canning Street, Burnley.

ARE you in a flat? Do you require a complete Station in a carrying case 15in. x 15in. x 5in.? 6V6—807 CW Phone TX. 50 Watt Power Pack—T.R.F. RX.—6V6 Modulator. All new components. Grey crackle finish. Labels. Chromium handles. Worth £30. Requires modification to RX. Bargain, £15. S.W. London.—Box E/28A, PARRS, 121 Kingsway, London, W.C.2.

A.R.88.D. receiver, 535-32,000kc. 6 bands, var. selectivity, crystal, B.F.O. bandsread, noise limiter, 14 valves, £55.—CLINTON, 20 Clifton Avenue, London, E.17.

BRS5689, clearing the following unused gear, 1R5, 1R5, 384, 1T4, 1299A, 955, 2A3, 6K7G, OZ4, EF50, 2P, Valves at 10s. each. No. 58, 8-valve Walkie-Talkie, complete with 2 mikes, 2 pairs 'phones, leads, aerials, battery box, etc., £7.—24, Rossie Island, Montrose, Angus.

CALLING Cardiff.—Allow me to quote you. All types gear obtained against order.—Write or call BRS10774, 14A Romilly Crescent, Canton.

CANADIAN Dow bug key. 1865.3 quartz crystal in holder, with certificate. Type Q5. Eddystone small pre-war metal cabinet. Type 902 cathode ray tube, 2in. Type 884 gas triode (1) 809, (2) 807. Surplus. All new.—G2BQC, 133 Carlton Road, Boston, Lines.

COMMUNICATION receiver for sale. Hallcrafters S.X.25. Super Defiant. Condition perfect. Recently checked, £45 or near offer.—Box E/1, PARRS, 121 Kingsway, London, W.C.2

OUR FRONT COVER

Mullard Beam Power Tetrode QY2-100

THE Mullard QY2-100 is a beam power tetrode in which stability of emission and vacuum is ensured by a zirconium coated molybdenum anode.

With an input of 150W. it will deliver an output of 50W as R.F. Amplifier class "B" telephony, approximately 90W as anode-modulated class "C" R.F. Amplifier, and approximately 110W. as R.F. Amplifier and oscillator class "C" telegraphy. It will, of course, give correspondingly greater outputs at the maximum rated input.

These figures apply for operation at frequencies up to 30 Mc/s, but the valve may be used at reduced ratings at frequencies up to 120 Mc/s.

The QY2-100 is interchangeable with the American type 813.

EX-Army W/Op. Student B.I.E.T., seeks situation where he may gain practical servicing experience. South England preferred.—Box D/38, PARRS, 121 Kingsway, London, W.C.2.

EX-NAVAL Officer (Communications Branch). 25 years experience all types receivers and transmitters (including installation, maintenance and servicing) licensed amateur, accustomed to stores, administrative work and control of large staffs, P.M.G., etc. Seeks situation, preferably in South-East London or North Kent. Available immediately.—Box E/26, PARRS, 121 Kingsway, London, W.C.2.

EXCHANGE.—Receivers, transformers, chokes, keys, valves, condensers. About £35 worth. What have you?—Write for lists.—Box E/7, PARRS, 121 Kingsway, London, W.C.2.

EXCHANGE.—Rolleicord Camera F4.5 Triotar compur rapid in leather case. Condition as new, for communication receiver, preferably Comet Pro.—G8BP, 69 Allen Road, Wolverhampton.

FOR SALE.—Six SH resistor kits, each containing 50 new pre-war wire wound vitreous enamelled resistors $\frac{1}{2}$ to 3 watt, 10%. Price 9s. including postage.—Also Hallcrafters Skyriider Marine, S-22-R for 220-240 volts. Little used. Six 6SG7's and 6H6's, I.E.E. Journals 1936-1945. Single copies or sets. What offers?—Box D/32, PARRS, 121 Kingsway, London, W.C.2.

FOR SALE.—British Physical Laboratories Universal meter, 1000 ohms. per volt, 13 ranges. As new. Surplus to requirements, £7 15s.—L. STERN, BRS11763, 42 Beaconsfield Road, Brighton.

FOR SALE.—Walkie-Talkie, with set of spare valves, one set phones, power pack, rod AE, telescopic AE; no batteries, £8.—W. A. GONNAN, 15 Northburn Street, Glasgow, C.4.

SEE YOU AT THE LONDON MEMBERS' LADIES NIGHT

to be held in

THE SOUTH HALL SUITE
VICTORIA HALLS
BLOOMSBURY SQUARE
HOLBORN, LONDON, W.C.1

on
SATURDAY, 7th DECEMBER

Dress Optional
Running Buffet
Licenced Bar

DANCING 6.30 p.m. to 11.30 p.m.

Tickets 5/- each, from District Representatives, Members of the Social Committee, or from Headquarters

FOR SALE.—Look page 257 R.S.G.B. Handbook. DX working full power transmitter, enclosed grey rack, fully metered, polished aluminium panels, four power racks, 1350 volts, etc. Post War valves, 6V6-807 Exciter—804 Suppressor Modulated, final. Nearest offer £80.—G5LC-3, Summer Avenue, East Molesey, Surrey.

FOR that QRO Rig. Transformer 1075-0-1075 Volts 350mA £4 10s. Swinging Choke 5/25 Henry 350mA. £1 10s. Three Smoothing Chokes 20 Henry 350mA. £1 15s. each. Filament Transformer 4V. 3Amp. 4V. 3Amp. C.T., 4V. 3Amp. C.T., £1 5s.—BECKWITH, BRS. 3430, Sunnyside, High Street, Kelvedon, Essex.

FOR SALE.—G.E.C. 6-watt amplifier 200/250 A.C., 14in. mains energised speaker 1000 ohm field, 15 ohm speech coil. "Rothermel" (De luxe) crystal pick-up. All in perfect order, as new, £14, or near offer the lot, or will sell separately.—G3VD, 80 Lansdowne Place, Hove, Sussex.

FOR the Ham.—£1 parcels of the following: 3000 pf., .001, .1, 1, 2, 4 and 25 uF. 150V ceramic twin-gangs. Mains transformer and choke bobbins and shrouds. Coil formers, etc. "INSTALL," 78 Oxford Road, High Wycombe.

GOODMANS 12 inch auditorium, completely untouched, boxed, £5 10s. Steel case, chassis, panel, 19 x 10 x 10 1/2, grey crackle, 40s. Brand new valves: 5Y3G, PX4, TDD4, 6Q7G, MU14, all Ss. each. Also MX40, MSPENB, 42, EF39, TH2, 62A8G, 10s. 6d. each.—P. W. BARNETT, Station Residence, London Road, St. Albans.

HALICRAFTER Ultra Skyriider communication receiver, 10-valve, crystal gate, continuous coverage 6 Mc/s, to 80 Mc/s., perfect condition, £40.—G3CQ, "High Beacon," Havering, Essex. Phone Romford 4608.

HALICRAFTERS-Skyriider Defiant SX24, as new, matched speaker, 550 kc/s - 44 Mc/s.; best offer secures.—R.A.W., 17 Tandridge Gardens, Sanderstead. Sanderstead 1979.

HAM-AIDS—Known the world over as Quality QSL's—Send for samples from G6XT, 47 Watson Street, Morley, Leeds.

HETERODYNE Frequency Meter, £1. Rich & Bundy, 250-0-250, 15s. Cydon transmitting condensers, 5s. 807, 10s. 6V6, 5s. TZ05-20, 5s. Condensers, chokes, transformers, valves. G2YZ, 32 Onslow Drive, Sidcup, Kent.

H.R.O. complete with coils and power pack. Excellent order, £65. C.W.Tx. coils for 80 and 160. 6L6-T20 and power pack for same, on two standard chassis's, £15. Hallierafter, S27, 27-84 Mc/s, £20. R.M.E. 69 and pre-selector, wants aligning, £40. 251 Stretford Road, Manchester, 15. Phone Moss Side 2281.

HALLICRAFTER Sky Champion for sale, 10 to 160 meter, perfect condition with mains dropping transformer, 1940 model, £25.—GW3VL, 14 Keynsham Road, Whitechurch, Cardiff.

HAMS!—Can we help you with your requirements? Eddystone, Raymart and other wellknown makes of short wave equipment. Condensers, Transformers and valves. Transformer Rewinds, Transmitters and Modulators built to your specification. Write for latest lists. S.A.E. All orders C.O.D.—G3WF-G3PO, 101 Evesham Road, Headless Cross, Redditch.

HORNBY Model Train Set, 20V. A.C. with transformer, Flying Scot Engine, trucks, lines, points, etc.—S.A.E. list, £12.—MARTIN, Castlemount, Workop.

MULTIMETER partly finished, 35s. M.C. voltmeters 0/30V, 0/35V, 10s. each. M.I. voltmeter 2 1/2 in. scale, 0/15V, A.C./D.C., 12s. 6d. RF thermo-couple meter, 0/500mA, new, unused, 25s. Ferranti, AF3, OPI, 7s. 6d. each.—MASSEY, 58 Wakefield Avenue, Hull.

NATIONAL. N.C.120. 13 Valve Communication Receiver, perfect condition, £56. Bargain.—CAMERON, 1487 Dumbarton Road, Glasgow, W.4.

NEW valves.—T55 (2), £2. 809 (1), £1. 832 (2), 25s. RK34 (1), 10s. Bug key, £1.—MARSHALL, "Moordlands," Hall Road, Rotherham.

NEW Valves for Sale.—813 (2), PT15 (2), 8020 (2), 9001 (4), 9002 (4), 6G6 (3).—Offers for all or separately to Box E/19, PARRS, 121 Kingsway, London, W.C.2.

OFFERS for new Corsor 339 oscilloscope. Advance B3C generator. Taylor 110A R/C bridge.—BRS 11975, 162 Lowestoft Road, Gorleston-on-Sea.

PORTABLE 30 watt factory made TX, 80-20 metres, EL32 C.O. and 6L6 P.A., A.C. mains or 6-volt battery; weight 20 lbs., coupler for single or double wire aerial, £55. With 4-valve super running from same power pack, £65. Howard Communication Receiver, Crystal gate, speaker, £42.—G6ZY, 47 Putney Hill, London, S.W.15.

PORTABLE communication receiver, 1.8 to 7.5 Mc/s. from 12 volt. D.C. supply 14. HRO. DC power pack 6v, almost new 7. Meters 0-25 amp. 4.0-350 mA C.3, new. S.A.E. for complete list to G3ADZ, Box E/4, PARRS, 121 Kingsway, London, W.C.2. or phone Ewell, Surrey 6202, evenings.

QSL cards. Samples Free.—For all your printing requirements write to 75 St. Andrew's Avenue, Elm Park, Romford, Essex.

R.S.S. LTD. can now offer their services to the amateur. We specialise in communications receivers. We have the finest equipped workshops, using the most up-to-date lab. instruments. Advice and estimates free.—Write or phone, 57 Digby Crescent, London, N.4. Stamford Hill 5389.

SALE.—New and boxed U.S.A. valves, 832 (4), 9003 (2). What offers?—Write Box D/13A, PARRS, 121 Kingsway, London, W.C.2.

SALE.—Evershed-Vignoles Ohm Meter. Two ranges covering 50-200,000 ohms. Internal battery. Perfect condition. First £5 secures. Test leads included.—WILLIAMS, 12 Avenue Road, Isleworth, Middlesex.

SALE.—New Taylor 90 meter, offer over £12. Modified R1155 separate power pack £22. Various valves, etc. Box D/28, PARRS, 121 Kingsway, London, W.C.2.

SALE.—D.C. Avo Minor, £3. One new and unused, T.20 30s. Two partly used, £1 each. Thordarson 60 watt Modulation Transformer 8000 primary to 10,000 and 5,000, Secondary, £2.—G3TC, 62 Ringsted Crescent, Crosspool, Sheffield, 10.

SALE.—H.R.O. Senior, rack mounting, pack 230 A.C. coils 2-30 Mc., unused, £75. A.R.77E 540 kc/s., 32 Mc/s., fitted crystal filter, noise limiter, £65. Both perfect and with unused spare valves etc. E.C.R.30 £2. 807's (2) 22s. 6d., KT66 (2) 12s. 6d., EF36 (4) 7s. 6d., each, unused S.A.E. for other spares.—Box D/37, PARRS, 121 Kingsway, London, W.C.2.

SALE or Exchange.—National 1-10 complete with coils and National power pack. Wanted communication RX, National preferred. Cash adjustment if necessary.—G3AJV, 27 Palin Avenue, Fagley, Bradford.

SALE.—D.C. Avomiror; perfect, 3 gns. Metal valves, 6N7, 10s., 6C5, 6J5, 6s. 6d. each.—BRS9757, Hillcrest, Oxford Road, Gerrards Cross, Bucks.

SALE.—Weston E.665 selective analyzer, as new. Offers.—T. BURNIE, 114 Church Street, Staines.

SALE.—Brand new and secondhand Tx and Rx Valves, Crystals, Mikes, Crystal and M.C. Vortexion 50 watt modulator. Mains Transformers, Chokes, Condensers, M.C. meters, also many other items. Send 1d. stamp for list.—G2DYV, 2 Outgang, Aspatria, Cumberland.

SALE.—Transformer, 500-0-500V, 200 mA, 4V 3-5A, and 3 at 4V 2-3A, all C.T. 35s. 5 U4G, 10s. Osram ACT.6 75W SW Triode and holder, £3. D.105 Crystal Mike, £2.—D. BARBER, 11 Cliffe End, Holmfirth, Nr. Huddersfield, Yorks.

SALE.—Two new 43 valves, one new 800 ohm. mains dropper 3 1/2 ins. Moving iron meter 0-2.5 amps. D.C. Lot, £2 5s.—G2GZ, 155 Grand Drive, London, S.W.20.

SALE.—Mullard GM3152 Oscilloscope, 500. Weston E669 Valve Voltmeter, 11s. M.C. meters: 1-0-1mA, 35s., 0-5mA 25s., 0-100mA moving iron, 7s. 6d. M.C. mike, 50s., Baker's Output Transformer, PX4's push-pull to 15 ohms, 20s. B.T.H. Gram Motor, AC/DC, offers. Rothermel Senior Crystal Pickup, 40s.—Box E/21, PARRS, 121 Kingsway, London, W.C.2.

SALE.—Surplus gear. 6AC7, 6AG7, 6V6, 9006, 6SN7, 6J5, 6SL7, 6Y6G, 6H8, 6E5, 7s. 6d. EF50, 6K8, 8s. 6d. U22, 6X5, 6H6, U14, 6s. DC2 PEN, 20s. All 100 per cent. Rotary Converter, 24VDC 1/P. 230V. 87amp. AC O/P, £6. Westinghouse M/C 0-1mA, 15s. High V. Condensers. A.C. Gram-Motor wanted.—BRS9139, 3 Kings Avenue, Kings Lynn.

SALE.—New and boxed U.S.A. Valves, 832 (4), 9003 (2). What offers?—Write Box D/13A, PARRS, 121 Kingsway, London, W.C.2.

SALE.—Unused (3) 9001, (1) 6SS7, (1) 6V6, (1) 6K8, (2) 12A5, (2) 6Q7, (1) 12AH7GT. First reasonable offer secures. Whole or part lot.—THOMPSON, 5 Railway Terrace, East Street, Southend, Essex.

SALE of spare Ham Gear. Philips 3152 Oscilloscope spare valves and CRT, £25. Precision Sigenator 100-20,000 kc/s., £12 10s. Res-cap Bridge, £12. A few continut testers, meters, motors, mikes, valves, etc., nearly all brand new.—BRS2990, 115 Norwood Road, London, S.E.24. (Tel. 7294).

SELLING OUT.—HK24 (1), £1. 807 (2), 866 (2), DET19 (1), all 11s. 6d. each. 5U4G (2) 5Z3 (1), 6L6 (1), 6L6G (1), all 6s. 6d. each. All in excellent condition. Many more valve and equipment bargains. Send 2jd. stamp for list.—Box D/27, PARRS, 121 Kingsway, London, W.C.2.

SHORT WAVE aeriials, assembled length 9 ft., folding down into 9 sections, copper rod with flexible connections. Complete with solid rubber base, 17s. 6d.—M.O.S., 24 New Rd., London, E.1.

SUPER Skyriider, SX23 (crystal filter, ANL, etc.) and D20, both as new, may be seen London, £60 or offers.—GW3ALE, BM/3ALE, London, W.C.1.

SX16 for Sale, 12in. Speaker to match. 500 kc/s. to 63 Mc/s. Offers over £40. Avo Oscillator (mains) brand new, £12 10s.—GM411, "Arnhem," Kilmacollin, Renfrewshire.

TRANS-RECEIVER. 58 MK1, Inc. Battery case and aeriials. Perfect, 8 gns., or offer.—BRS12171, 34 Colne Road, London, N.21. Lab. 3217.

VALVES.—unused. EF50's, EBC33's, 8D2's, P625A's, TP1340, 7s. 6d. each. 384's, IS5's, IT4's, IR5's, 15s. each. 807's, PT15's, 17s. 6d. each. PZ1-75's, 35s. each. New bridge type metal rectifiers, 250v. 150mA, 12s. 6d. each. Stamp please!—Box E/25, PARRS, 121 Kingsway, London, W.C.2.

WANTED.—Coils for Eddystone 358X receiver; new or used, any range. Prices to G8VX, 25 John Street, Thurscoe, Nr. Rotherham, Yorkshire.

WANTED Urgently.—SX24, HQ12OX, NC81X or similar receiver. Particulars, price to: BRS13120, 66 Greystone Avenue, Burnside, Rutherglen, Glasgow.

WANTED.—HRO Coil 500-1000 kc/s. (456 I.F.)—Price to G8BQ, 51 Fydeall Street, Boston, Lincs.

WANTED.—HRO Senior coils, 480-960 kc/s, and 3.5-7.3 Mc/s. with Bandsread.—State condition and price.—Box E/15, PARRS, 121 Kingsway, London, W.C.2.

WANTED Urgently.—A Communications Receiver. Full details and price please, to G2BNH, 366 Gillott Road, Edgbaston, Birmingham.

500-0-500 170mA. 4v. 4a. 230v. Primary 3000v. test. Heavy duty transformers, 4 1/2 ins. 6d. 150mA. 100 ohm Chokes 1000v. test, 17s. 6d. Plessey 500v. 8A., screw base electrolytics, 5s. 6d. All carriage paid. C.W.O. or C.O.D.—G2FMW, 365 West Barnes Lane, New Malden, Surrey.