

THE T & R

BULLETIN

A JOURNAL FOR
RADIO EXPERIMENTERS

Vol. 16 No. 5 NOVEMBER 1940 (Copyright)

Price 1/6

POSTAL CENSORSHIP PERMIT No. B.305

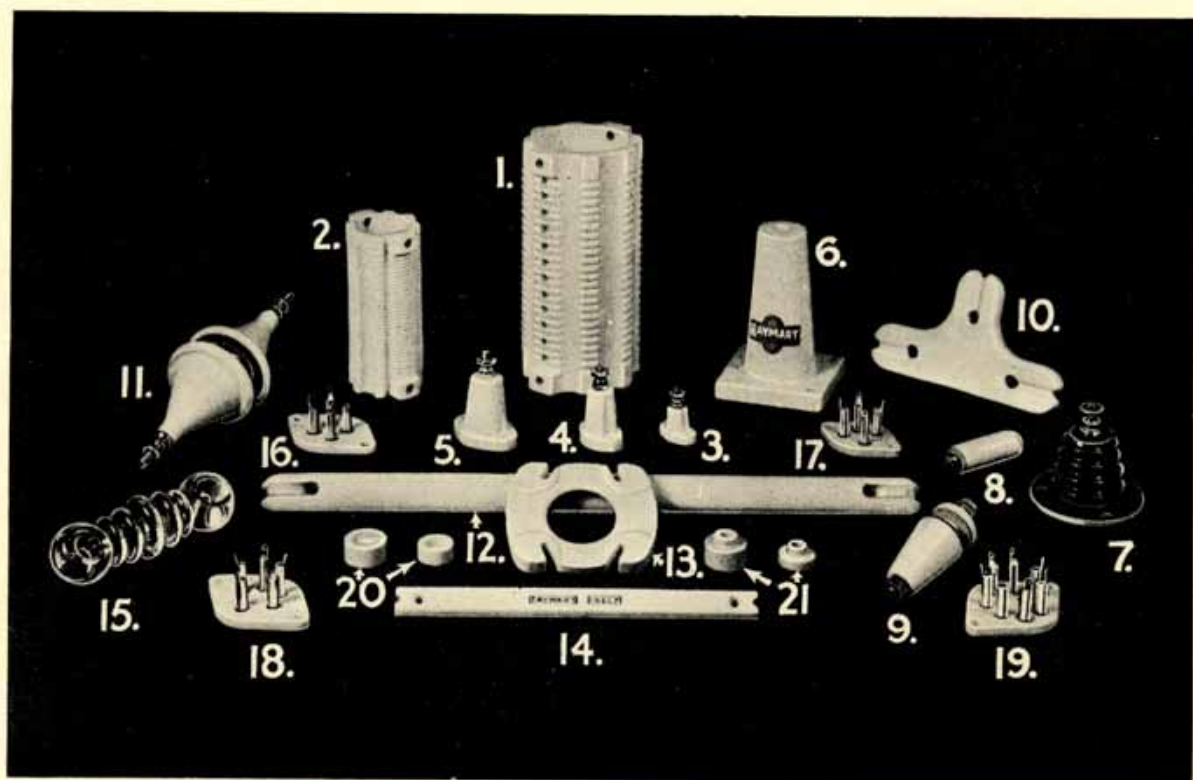

RAYMART, LTD.

44 & 48 HOLLOWAY HEAD, BIRMINGHAM, 1

OUR ILLUSTRATION ABOVE GIVES BUT A SMALL INDICATION OF THE WIDE VARIETY OF INSULATORS AND CERAMIC GOODS AVAILABLE FROM RAYMART, WHO CARRY THE LARGEST RANGE OF THESE PRODUCTS IN THE COUNTRY. THERE ARE MANY OTHER RAYMART LINES APPROVED AND USED BY H.M. SERVICES. MICRO-VARIABLE CONDENSERS—PRECISION DIALS AND A LARGE SELECTION OF SPECIALITIES FOR SHORT-WAVE WORK.

Cables : Raymart, Birmingham.

Telephone : Midland 3254

Government departments — Manufacturers — Servicemen etc., are invited to send us their enquiries.

ACCURATE Instruments for ACCURATE Testing



BRITISH
MADE

The word "Avo"
is our registered
Trade Mark.

In case, complete with leads, interchangeable crocodile clips and testing prods; and with comprehensive instruction booklet.

The D.C.

AVOMINOR

Electrical Measuring Instrument

This instrument provides precision testing facilities at a truly modest cost. Incorporating a fully jewelled moving-coil movement and a 2½-in. scale, it permits accurate readings of milliamps., volts and ohms, with ranges adequate for the majority of normal circuit, battery and resistance tests. The total resistance of the meter is 100,000 ohms; full scale deflection of 300v. or 600v. is obtained for a current consumption of only 3mA. and 6mA. respectively.

Current: 0 to 120 milliamps (3 ranges).

Voltage: 0 to 600 volts (6 ranges).

Resistance: 0 to 3 megohms (4 ranges).

The UNIVERSAL

AVOMINOR

Electrical Measuring Instrument

A precision meter for measuring A.C. and D.C. volts, D.C. milliamps, and ohms. It has 22 ranges. An accurate moving-coil movement gives a 3-in. full scale deflection. Total resistance is 200,000 ohms. Complete with instruction booklet, leads, testing prods and crocodile clips.



Write for fully descriptive literature and current prices.

Sole Proprietors and Manufacturers:

THE AUTOMATIC COIL WINDER & ELECTRICAL EQUIPMENT Co., Ltd.

Winder House, Douglas Street, London, S.W.1.

Phone: Victoria 3404-7

Keep up-to-date

with the latest developments in electronic engineering, television and allied subjects, by reading regularly

A
HULTON
PUBLICATION

ELECTRONICS and TELEVISION & Short-wave World

It provides all the latest information on short-wave communication, reports on test equipment and new receivers.

Each month ELECTRONICS AND TELEVISION brings you information in the radio and allied fields that will keep you right up-to-date in subjects that are beginning to have an enormous influence on modern development.

FROM ALL NEWSAGENTS AND BOOKSTALLS
MONTHLY, PUBLISHED 25th OF PRECEDING MONTH **PRICE 1/6**

Editorial and Advertisement Offices:

Hulton Press Ltd., 43 Shoe Lane, London, E.C.4

Free

A post card to the Editorial Offices of the journal will bring you, post free, a specimen copy.

The
Incorporated Radio Society
of Great Britain

53, VICTORIA STREET,
LONDON, S.W.1

November 15, 1940.

DEAR SIR (OR MADAM),

I am directed to advise you that in accordance with the Articles of Association, the ANNUAL GENERAL MEETING of the Society will take place in the Council Room, at the Institution of Electrical Engineers, Savoy Place, Victoria Embankment, London, W.C.2, at 2 p.m. prompt, on Saturday, the 14th day of DECEMBER, 1940.

AGENDA.

1. To approve the Minutes of the last General Meeting as published in the January 1940 issue of THE T. & R. BULLETIN.
2. To approve the Honorary Treasurer's Report.
3. To approve the Council's Annual Report.
4. To announce the names of Officers and Members to serve on Council for the year 1941.
5. To elect an Honorary Auditor for the year 1941.
6. To pass a vote of thanks to the President and Council of the Institution of Electrical Engineers.

Following the meeting Mr. A. D. Gay will deliver his Presidential address.

Yours faithfully,

JOHN CLARRICATS,

Secretary-Editor.

REPORT

OF THE HONORARY TREASURER

It is my pleasure to present the audited accounts of the Society, for the year ended September 30, 1940.

Income over Expenditure amounts to £345; a record in Society history. This very satisfactory state of affairs can be attributed first, to the effectiveness of the economies introduced by Council immediately war was declared, and second to the splendid support given by members generally to the request of Council to help them carry on the work of the Society.

Throughout the year the Council has watched with considerable pleasure a steady increase in revenue over expenditure, and in this connection thanks must be recorded to the Secretary-Editor who has consistently provided me with the most carefully prepared financial statements.

It is noteworthy that during the year, 979 members took advantage of the reduced subscription fees, representing a "loss" on pre-war rates of £295.

In spite of war conditions it has been possible to maintain the quality of the Society's Journal at a high standard. Advertising revenue has been very satisfactory indeed and reckoned as a percentage of the production costs, was greater than during the previous year. Due to paper difficulties it was possible to publish only occasional issues in excess of 32 pages.

Salaries show a fall of nearly £250 due to staff reductions, whilst the change-over from a Central London office to a temporary office has resulted in a further reduction of £60. Printing and Stationery expenses are £134 lower and in spite of big increases in postal rates, Postage expenses show a reduction of £36. Due to prevailing circumstances, Travelling and Entertainment expenses have been much lower, as has been the cost of hiring halls for meetings.

The revenue derived from the sale of publications, etc., together with revenue obtained from the handling of American publications, amounted to £130.

It will be noted that the £1,000 3½ per cent. War Loan bought originally for £1,049 was sold during the year at a loss of £52. The decision to realise was made in view of the uncertainty of the stock market. The proceeds of the sale were immediately invested in 3 per cent. Defence Bonds.

I am confident that the same watchful attention to the Society's finances, which characterised the past year, will be given by the new Council.

An examination of the Accounts will show that the financial position of the Society has never been so satisfactory as at the end of the year under consideration.

(Signed) H. A. M. CLARK,

Honorary Treasurer.

INCORPORATED RADIO SOCIETY OF GREAT BRITAIN.

BALANCE SHEET as at 30th SEPTEMBER, 1940.

LIABILITIES.		£	s.	d.
SUNDRY CREDITORS—				
Sir J. Causton & Sons, Ltd.—				
Amateur Radio Handbook, 2nd edition	497	10	0	
Printing and Posting T. & R. Bulletin (September, 1940)	76	19	2	
Evans Spencer & Co.—				
Blocks—T. & R. Bulletin (September, 1940)	7	0	11	
American Radio Relay League	57	7	2	
Radio Ltd.	9	19	0	
Telephone and Sundries	19	15	0	
				668 11 3
ACCUMULATED FUND—				
Balance 1st October, 1939	1,423	6	3	
Add—Excess of Income over Expenditure for the year	345	6	7	
				1,768 12 10
				<u>£2,437 4 1</u>

ASSETS.		£	s.	d.
FURNITURE AND FIXTURES (At Cost, less Depreciation)—				
As at 1st October, 1939	£116	17	8	
Less—Depreciation written off	100	0	0	
				16 17 8
SUNDRY DEBTORS—				
Parrs Advertising Ltd.—				
T. & R. Bulletin	112	7	10	
Amateur Radio Handbook, 2nd edition	68	10	0	
Sundries	50	18	5	
				231 16 3
INVESTMENT (At Cost)—				
£1,000 3% Defence Bonds	1,000	0	0	
CASH—				
At Bankers and in Hand	1,138	4	7	
On Deposit at Bank	50	5	7	
				1,188 10 2
				<u>£2,437 4 1</u>

AUDITOR'S REPORT.

I have audited the above Balance Sheet dated 30th September, 1940, and have obtained all the information and explanations I have required. In my opinion, such Balance Sheet is properly drawn up so as to exhibit a true and correct view of the state of the Society's affairs, according to the best of my information and the explanations given to me and as shown by the books of the Society.

JOHN OCKLESHAW, F.C.A.,
*Chartered Accountant,
Honorary Auditor.*

Dewar House,
11 Haymarket, London, S.W.1.
21st October, 1940.

Passed by Council, 13th October, 1940.

Signed by—
ARTHUR E. WATTS, *President.*
H. A. M. CLARK, *Hon. Treasurer.*
H. V. WILKINS
F. J. H. CHARMAN } *Members of Council.*
JOHN CLARRICOATS, *Secretary-Editor.*

INCOME AND EXPENDITURE ACCOUNT for the year ended 30th September, 1940

EXPENDITURE.		£	s.	d.
Last Year 1938/39 To nearest		£	s.	d.
162	To Rent and Office Cleaning	105	18	1
1,005	„ Salaries and National Insurance	759	13	6
9	„ Light and Heat	6	17	6
24	„ Telephone	12	8	8
40	„ Sundry Expenses	25	1	11
10	„ Income Tax on Interest 1939	12	5	0
188	„ Printing, Stationery and Certi- ficates	54	14	3
132	„ Postages	96	14	3
14	„ Convention Expenses	—	—	—
32	„ Hire of Hall and Refreshments	12	0	0
1,159	„ T. & R. Bulletin, less received from advertising	626	8	1
2	„ Subscription B.S.I.	2	2	0
47	„ Travelling Expenses	22	3	10
—	„ Loss on Sale of 3½% War Loan	52	8	9
10	„ Depreciation of Furniture and Fixtures	100	0	0
8	„ Balance being excess of income over expenditure for year to Balance Sheet	345	6	7
				<u>£2,234 2 5</u>

INCOME.		£	s.	d.
Last Year 1938/39 To nearest		£	s.	d.
2,668	By Subscriptions	2,085	11	11
95	„ Profit on Sale of Publications, Society Badges, Books, etc.	£113	15	2
44	„ Amateur Radio Handbook	16	17	4
				130 12 6
—	„ Bank Deposit Interest	0	8	0
35	„ Interest 3½ per cent. War Loan	17	10	0
				<u>£2,234 2 5</u>

Sir Joseph Causton & Sons, Ltd.
Brettenham House,
Lancaster Place, London, W.C.2

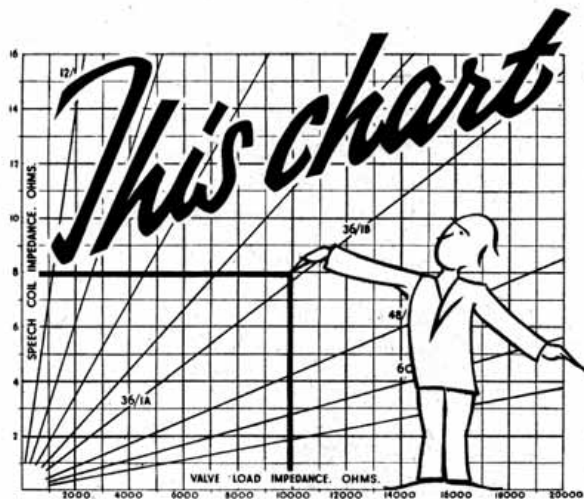

shows how

ONE
TRANSFORMER
meets All
REPLACEMENT
NEEDS



CORRECT MATCHING *Simplified*

Speech coil impedances may vary—valve loads may fall within a very wide range, yet, as this chart shows, you can always match up correctly with the ONE type Goodmans Transformer—the "101." A typical example is shown. An 8 ohm coil to match a 10,000 ohm load . . . the correct ratio indicated is 36 : 1B. The tapping instructions provided with each transformer show the correct connections. It's as simple as that for **any** valve and coil combination. And because of the unique system of series and parallel winding, an exceptionally high degree of efficiency is attained almost irrespective of the tappings used. Send coupon for full description and chart with tapping instructions.

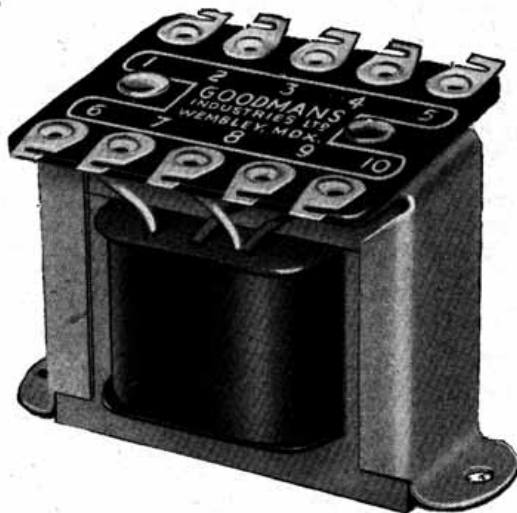

GOODMANS
101 MULTI-RANGE
REPLACEMENT

OUTPUT TRANSFORMER

GOODMANS INDUSTRIES, LTD.
 Lancelot Rd., Wembley, Middx. 'Phone: Wembley 4001 (5lines)

For practically all output valves from 2,000 to 20,000 ohms (including Q.P.P., Class B and Push-Pull) and speech coils from 1 to 16 ohms.

RATIOS AVAILABLE :

12 : 1 18 : 1 24 : 1 30 : 1
 36 : 1* 48 : 1* 60 : 1 72 : 1

(*Centre tapped.)

LIST PRICE

6/3

Boxed complete with instructions.

POST THIS COUPON to:

GOODMANS INDUSTRIES, LTD.,
 Lancelot Rd., Wembley, Middx.

Please send me full particulars of GOODMANS "101" Multi-Range Replacement Output Transformer together with chart and tapping instructions.

TRB.540

Please attach this to your card or letter heading.

ELECTRADIX

TOWNSEND WAVEMETERS, Model N.M.T., in double-lid case. Range 190 m. to 3,000 meters, and will generate waves accurately over this band. A £10 Wavemeter for 70/-.

DIRECTION FINDERS. Marconi B.T. Radiogoniometers, for ascertaining direct from where wireless signals are coming, in polished cabinet 9 in. x 10 in. x 11 in. with direction pointer. Price £3. Listed £40.



POWER ALTERNATORS, H.F., 500 cycles, 20 amps., 10 volts with coupled exciter, £3 10s. Worth treble. Ditto double, type W. 500 cycles, 100 volts, 3 amps., and 70 volts, 3 amps. D.C., £5 10s.

RADIO ROTARY CONVERTERS. For D.C. mains to 230 v. A.C. output. In silence cabinet, with filter. All sizes in stock, from 15 watts upwards; 30, 50, 100, 200, 400 and 800 watts; 1 kw., 1½ kw., etc. Also 50-watt size, 12 volts and 50 volts input. T.V.T. Sets, 6 volts to A.C. 25/-.

LIGHTING AND CHARGING PLANTS

500-watt, Petrol Electric, single-cyl. 2-stroke, water-cooled, self-oiling, Stuart Turner engine; mag. ign., coupled to 50/70 volts, 10 amps., shunt dynamo, 1,000 r.p.m., £17 10s.
150-watt Engine and Dynamo on similar lines but coupled to 25/30 volts, 6 amps. dynamo. Immediate deliveries of either model, £13.

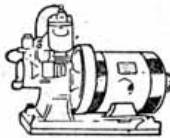

"NITDAY" BATTERY CHARGERS

Metal Rectifiers—Steel Chassis.

- Model N/A 2½, Radio Home Charger. To charge 2 volts, ½ amp. ... 12/6
- Model N/A 6½, Trickle Charger. To charge 6 volts, ½ amp. ... 17/6
- Model N/B 6/1, Car Charger. To charge 6 volts, 1 amp. ... 24/-
- Model N/B 6/1½, Car Charger. To charge 6 volts, 1½ amps. ... 27/6
- Model N/C 6/2, Car Charger. To charge 6 volts, 2 amps. ... 37/-
- Model N/D 12/1, H.M. Car Charger. To charge 12 volts, 1 amp. ... 38/-
- Model N/D 12/2, N.K. Car Charger. To charge 12 volts, 2 amps. ... 55/-
- Model N/E 2, Doubler. Meter Car Charger. To charge 6 volts and 12 volts, 2 amps. ... 65/-

All Models for 200/250-volt input.

EDISON HIGH CAPACITY STEEL CELLS at half price for stand-by lighting, 120 A.H. to 300 A.H., at 30/-, Makers' price is £5. Ask for leaflet. **FULL PARTICULARS** gladly given as far as we are able to A.R.P. ENQUIRIES.

ACCUMULATORS, for stand-by H.T., at 6d. per volt. 3 amp.-hours, in 24-volt unit crates, glass cells, 12/- each. Can be parallel-charged off 12 volts.

MOTORS. We still have a good stock of fractional H.P. motors, A.C. and D.C.

SWITCHBOARD, PANEL AND PORTABLE METERS. We can supply 8-in., 6-in., 3-in. and 2-in. meters in certain ranges still at the old prices.

Morse Practice Sets, Keys, Buzzers, Morse Recorders, Signal Lamps, Field Telephones, Headphones, etc.

Stamped envelope must be enclosed for Free Bargain List "T.R." or for replies to enquiries.

ELECTRADIX RADIOS
218 UPPER THAMES STREET, LONDON, E.C.4
Telephone: Central 4611

MORE TESTS— in less time and at lower cost with

TAYLOR METER

74 RANGE UNIVERSAL METER



Note these important features:—

METER

4½" square type Taylor moving coil meter.

SCALES

There are 6 scales, the outer being 3½" long.

RANGES

- D.C. VOLTS.** 0-0.1, 0-0.2, 0-2.5, 0-5, 0-10, 0-20, 0-25, 0-50, 0-250, 0-100, 0-200, 0-250, 0-500, 0-1,000, 0-2,000.
- A.C. VOLTS.** 0-2.5, 0-5, 0-10, 0-20, 0-25, 0-50, 0-100, 0-200, 0-500, 0-1,000, 0-2,000.
- OUTPUT.** 0-2.5, 0-5, 0-10, 0-20, 0-25, 0-50, 0-100, 0-200, 0-250, 0-500, 0-1,000, 0-2,000.
- D.C. CURRENT.** 0-250 micro amp., 0-500 micro amp., 0-1 m/a., 0-2 m/a., 0-10 m/a., 0-20 m/a., 0-100 m/a., 0-200 m/a. 0-1 amp., -2 amp., 0-10 amp. 0-20 amp.
- A.C. CURRENT.** 0-250 micro amp., 0-500 micro amp., 0-25 m/a., 0-50 m/a. 0-0.25 amp., 0-0.5 amp., 0-2.5 amp., 0-5 amp.
- OHMS.** 0-1,000, 0-100,000, 0-10 meg. (0-100 meg. with external battery.)
- DECIBELS.** -22 to +8 -10 to +20, -2 to +28, +10 to +40, +18 to +48, +30 to +60.

Adapters are available for measuring Capacity and Inductance also for increasing voltage range to 5,000-10,000 A.C. and D.C., and for low resistance measurements.

MODEL 81A.
4,000 ohms per volt
A.C. and D.C.

£12-12-0

(No purchase tax payable.)

Supplied complete with Instruction Book and 3 test leads.
BRITISH MADE. GUARANTEED 6 MONTHS.

Fully descriptive Brochure, free on request.

Deliveries at present, ex-stock.

TAYLOR

Electrical Instruments Ltd.,
419-422 Montrose Avenue,
SLOUGH, Bucks.
Phone: Slough 20061

Principles of TELEVISION ENGINEERING

By Donald G. Fink

Managing Editor: "Electronics"

541 pages, 9 x 6, 311 Illustrations, 35/- net.

HERE is a book that brings together conveniently for the radio engineer and radio amateur the basic principles on which television rests and illustrates the application of these principles in the standards of transmission and in practical equipment now being used. The book gives the reader an understanding of the functions of television equipment and provides the data on which the design and operation of the equipment depend.

The presentation is arranged in the logical sequence of events which take place in the transmission of a television programme, beginning with the camera, through the subsidiary amplifying and transmission equipment, radiation through space, reception and amplification, detection, and finally image reproduction.

Contents

Preface	5. The Video Signal
1. Television Methods and Equipment	6. Video Amplification
2. Image Analysis	7. Carrier Transmission of Video Signals
3. Fundamentals of Television Camera Action	8. Image Reproduction
4. Formation, Deflection, and Synchronisation of Scanning Beams	9. Television Broadcasting Practice
	10. Television Receiver Practice
	Appendix
	Index

MCGRAW-HILL
PUBLISHING CO., LTD.

Aldwych House, London, W.C.2

Miles in front!

Here is an interesting extract from a letter recently sent us by a Candler student who is now serving with the R.A.F. :—

"I should like to thank both yourself and the company for the great start which I obtained through taking your Junior Code Course. The experience which I gained from that has kept me miles in front of others who relied on obsolete means of learning code."

F. W. M.

In last month's issue of the *T. & R. Bulletin* we gave a selection of other similar letters from students taking either the Advanced or Junior Course. All original letters from which the extracts were taken can be inspected at the London office.

CANDLER CODE COURSES

have been responsible for the training of thousands of skilled W/T operators who now hold responsible positions in the Services, Commercial Companies and the Mercantile Marine. Why not fill in the Coupon and learn more about this remarkably efficient Candler method of Code training.

The **JUNIOR Scientific Code Course** is for beginners. It teaches all the necessary code fundamentals scientifically.

The **ADVANCED and High-Speed Telegraphing Course** is for operators who want to increase their w.p.m. speed and improve their technique.

The **TELEGRAPH Touch-Typewriting Course** is for those who want to become expert in the use of the typewriter for recording messages.

Courses supplied on Cash or Monthly Payment terms.

COUPON

Please send me a Free Copy of the Candler "Book of Facts."

NAME

ADDRESS

Post Coupon in ld. unsealed envelope to London Manager

CANDLER SYSTEM CO.
(Room 55), 121, KINGSWAY, LONDON, W.C.2.
Candler System Co., Asheville, North Carolina, U.S.A.

The Incorporated
RADIO SOCIETY OF GREAT BRITAIN

Registered Address:—
 53 VICTORIA STREET
 LONDON, S.W.1

Temporary Office:—
 16 ASHRIDGE GARDENS
 LONDON, N.13
 Telephone: Palmers Green 3255.

COUNCIL 1940.

PRESIDENT:
 ARTHUR E. WATTS (G6UN)

**EXECUTIVE
 VICE-PRESIDENT:**
 A. D. GAY (G6NF)

**IMMEDIATE
 PAST PRESIDENT:**
 E. D. OSTERMEYER (G5AR)

**HONORARY
 TREASURER:**
 H. A. M. CLARK (G6OT)

HONORARY EDITOR:
 ARTHUR O. MILNE (G2MI)

SECRETARY-EDITOR:
 JOHN CLARRICOATS (G6CL)

F. CHARMAN (G6CJ)
 D. N. CORFIELD (G5CD)

MEMBERS:
 E. A. DEDMAN (G2NH)
 E. L. GARDINER (G6GR)
 S. K. LEWER (G6LJ)

J. W. MATHEWS (G6LL)
 H. V. WILKINS (G6WN)

CHRISTMAS IS COMING!

What more appropriate present can you send
 to your pal on active service than a copy of
 the new and enlarged

SECOND EDITION

OF

THE AMATEUR RADIO HANDBOOK

328 Pages. **25** Chapters.

Right up to date. Fully illustrated.

PRICE **4/2** POST FREE.

If he is a member, send a couple of hundred sheets of
 headed notepaper, a call sign emblem badge and a copy of
 the Handbook.

Special offer of the three items **12/-** post free.

All Communications to Sales Dept.,

RADIO SOCIETY OF GREAT BRITAIN, 16, Ashridge Gardens
 London, N. 13

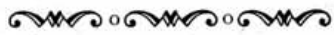

FULL LIST OF SALES DEPT. ITEMS

Call Sign—Emblem Badge ...	2/6
Call Sign—Bar Brooch ...	2/6
Call Sign—Car Plaque ...	4/6
Emblem Badge ...	1/6
Emblem Car Plaque ...	3/6
Kilocycles to Metres Booklet	1/6
Notepaper, 100 sheets ...	3/-
Ditto, overprinted ...	8/-
Notepaper, 200 sheets ...	5/9
Ditto, overprinted ...	12/6

American Publications★

A.R.R.L. Subscription to	
“QST” ...	17/6
Radio, Ltd., Subscription to	
“Radio” ...	21/-
(Two years) ...	37/6
A.R.R.L. Handbook, 1941 ...	10/-
A.R.R.L. Antenna Handbook	4/-
“Radio” Handbook, 1941	10/6

★Ordered direct from U.S.A.

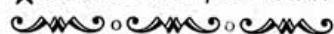

THE T. & R. BULLETIN

OFFICIAL JOURNAL
OF THE
RADIO SOCIETY
OF GREAT BRITAIN



DEVOTED TO THE
SCIENCE
AND ADVANCEMENT
OF AMATEUR RADIO

Hon. Editor: ARTHUR O. MILNE

Secretary-Editor: JOHN CLARRICOATS

Advertisement Manager: HORACE FREEMAN

Vol. XVI. No. 5.

CONTENTS

NOVEMBER, 1940

	Page		Page		Page
A Frequency Meter of New Design	130	Mathematics for the Radio Amateur	140	The Month "Off" the Air—October, 1940	153
The Construction of a Crystal Band Pass Filter	134	112-224 Mc. Operating Hints	142	The 28 Mc. Band	154
An Emergency Receiver for the Home Service	136	Experimental Section	146	The Ultra-Highs	154
The W3EDP Presents another Aerial Problem	139	Khaki and Blue	148	"Ham-Radio" Crossword	155
		Silent Key	149	British Isles Notes and News	156
		On Active Service	150	Belfast Y.M.C.A. Radio Club	160
		Wings Over the Tumuli	151	Book Review	161
		73	152	Headquarters Calling	163

AMATEUR TELEVISION

WE'VE just bumped across a subject which in our humble opinion would provide the basis for a really lively debate if times were normal. As they are not, your scribe proposes to take one side of the table leaving the membership, if it so wishes, to scrap from the other. But do please remember the views which follow are personal and do not necessarily agree with those which may be held by members of Council.

Maybe, those who subscribe to American ham journals will have noticed in recent issues that a very determined effort is being made to interest the "fraternity" in television. So far so good, but unfortunately, in our opinion, that interest is not being confined to reception, but to a full blooded link up with amateur telephony in the 112 Mc band.

As we understand it American amateurs are being invited to equip themselves for this new development, heralded as one of the greatest in history. We should be the last to criticise any move aimed at advancing the technique of television, but we contend that the restricted amateur bands, as internationally agreed, are not the place for such experiments. Television must remain a selfish service—"eating up kilocycles"—until some new epoch making method of transmission is evolved. For that reason we argue that those who wish to link up amateur television with amateur telephony should be given a separate part of the spectrum in which to out-jam one another! To permit television in the 112 Mc band is to restrict seriously all normal amateur telegraphy and telephony experiments.

If this development "catches on," it is likely to affect the amateurs in the large towns principally, because we have yet to be convinced that, even with a kilowatt input, the man in the backwoods will stand a hope of seeing his pal a few hundreds of miles away. If that contention is correct, and it seems logical enough, the keen c.w. men living in any large city will find their task of working other c.w. stations very difficult indeed.

It may perhaps be argued that television, being a new science (or is it an art?), should be given preference over the old-fashioned telephonic and telegraphic methods of communication, but somehow we think that very few of the ordinary hams of America will appreciate having to contend with even 120 line television transmissions within *their* bands.

Television was making rapid strides in this country when war broke out, and an increasing number of Society members were taking more than a passing interest in its development, but we do not believe that many of them would have agreed then to the operation of amateur

(Continued on page 164).

A FREQUENCY METER OF NEW DESIGN.

By J. W. MATHEWS (G6LL)*

NEARLY every amateur possesses a frequency meter of some sort, even if it only takes the form of a simple absorption type, but few seem to have interested themselves sufficiently to construct a really good and reliable heterodyne instrument.

Before September 1, 1939, it was very apparent that the importance of accurate frequency checking was growing, and the necessity for the ability to know the exact frequency, within known limits, that the transmitter was working on, was becoming essential.

This was due largely to the increase in the number of stations using some form of variable frequency drive, instead of a more or less fixed crystal frequency.

An accurate knowledge of frequency was also essential for the arranging of schedules, and to assist in the reduction of interference between stations.

The ability to place the receiver on any desired frequency will be appreciated, and as a natural corollary, the ability to measure the frequency of any station heard.

The extremely high degree of accuracy obtained by some commercial concerns affords an excellent opportunity to check the calibration of the instrument at regular intervals. The accuracy of some of these transmissions may be as high as one part in ten millions.

Accuracy

For normal amateur purposes an accuracy greater than about one part in one hundred thousand is not easy to obtain, but this accuracy is usually sufficient for most amateur requirements.

There are two methods of reading frequency from the meter. One employs a chart or curve, which has previously been prepared, and which shows frequency plotted against dial reading. The other method is known as the "Interpolation System," and consists of mixing the outputs of a variable and a fixed oscillator of known frequency and counting harmonics which are heard as beat notes. Then a knowledge of the frequency coverage of one degree of the dial, and of a particular harmonic will give the frequency at which the meter is adjusted.

The first method is undoubtedly superior since it is much more positive and quicker than the second. There is also much less chance of making a mistake in reading a curve than in counting harmonics and degrees.

Certain precautions should of course be taken in the preparation of the curves, and they should be carefully and accurately drawn on a fairly open scale so that one-tenth degree dial readings may be read. It is not practicable to read to less than one-tenth degree with an ordinary vernier dial, without resorting to guesswork, which should always be avoided.

Sub-Standards

The arrangements for checking the calibration of the frequency meter should be made with care, and if some method of constant check can be arranged,

small variations in oscillator calibration can be corrected as they occur.

A simple sub-standard of considerable accuracy may be constructed with the use of a 100 kc. crystal. These are obtainable with a very low temperature co-efficient (about six parts in a million), and consequently in normal use will only have a possible variation of about six cycles. It is also possible to arrange for the frequency of the crystal to be varied over small limits so that it may be checked and adjusted against a commercial transmission of known frequency and accuracy.

A great advantage of having such a sub-standard available for instant use is that the variable oscillator section may be constructed with ordinary good class components, since it need only hold its calibration accurately for short periods. In practice it will usually be found that the calibration will require only very slight adjustment over quite long periods.

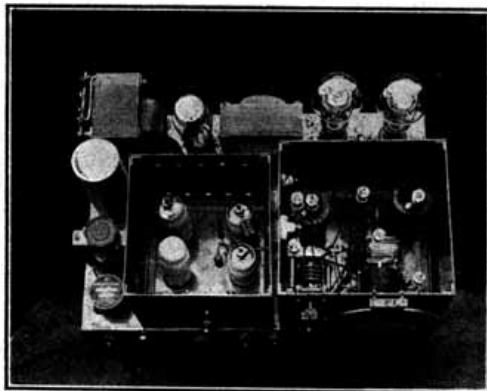

Fig. 1.

A general view of the Frequency Meter showing clearly the position of all components on the top of the chassis.

Variable Frequency Oscillators

There are several types of oscillator circuits that may be used, but in general the electron-coupled type is most popular. It has the advantage of stability and ease of operation and is rich in harmonics. But a more suitable circuit still is the Franklin. This circuit was developed by C. S. Franklin of *Marconi Co.*, and is used in the drive stage of a large number of high-power commercial stations. It is extremely stable and has the great advantage that quite large variations in H.T. and L.T. supplies to the valves will not affect the frequency at which it is oscillating. It is particularly adaptable for switched circuits since one contact only is necessary to change from one coil to another.

Since the chief considerations of frequency-meter oscillators are stability and simple rigid construction

*In collaboration with D. N. Corfield, D.L.C. (Hons.) G5CD.

this circuit, which obviously combines these points, is particularly suitable.

The most important factor in the construction of a frequency meter is the consideration of variations of calibration due to temperature changes. This can assume alarming proportions if due care is not exercised.

Components

Suitable valves should be chosen, and they should operate at a low anode current. There should be large metal conducting surfaces to remove heat produced by the cathode heaters. All coils and their associated condensers should be kept remote from sources of heat. De-coupling and other resistances

should be of a size large enough to operate for long periods without warming up appreciably. The coils and tuning condensers should be in a thick metal box, which will materially assist in keeping them at an even temperature.

It is essential that good quality components be used as these can be a source of continual trouble if of inferior make. They will be less affected by temperature changes, and the calibration will generally remain more constant. A good dial of precision design, with a vernier, is also essential and should always be provided. All coil formers must be rigid and of low loss material, with the turns firmly cemented in position with some suitable compound, for example Polystyrene cement.

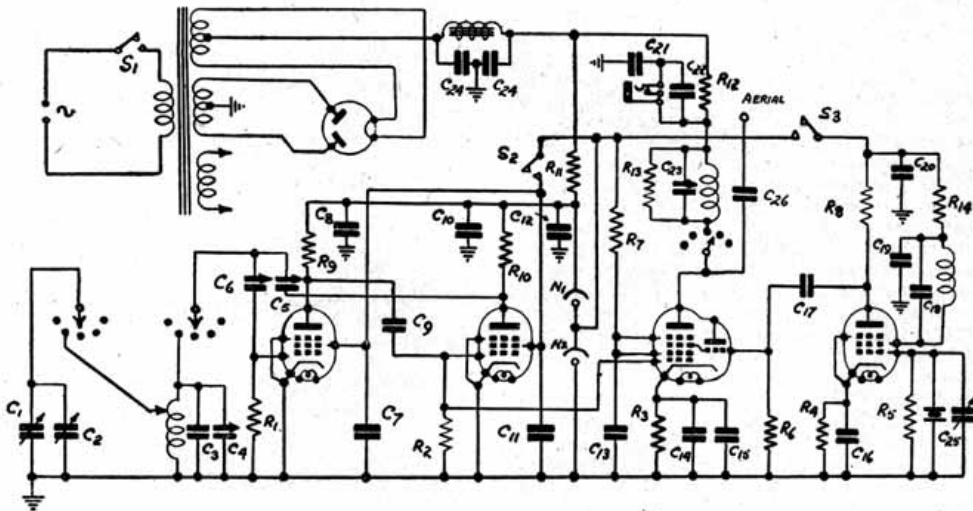

Fig. 2.

Circuit diagram of the Frequency Meter. It should be especially noted that for the sake of clarity only one tuned circuit is shown connected to the stud switches. In the actual design separate circuits are connected to the studs as described in the text.

Resistances and Condensers.

R1	250,000 ohms	1/2 w. Erie.
R2	250,000	" " " "
R3	350	" " " "
R4	500	" " " "
R5	2 megohms	1/2 w. Erie.
R6	50,000 ohms	1/2 w. Erie.
R7	5,000	" " " "
R8	100,000	" " " "
R9	1,000	" " " "
R10	1,000	" " " "
R11	2,000	20 w., Eddystone type 933.
R12	20,000	" " " "
R13	10,000	" " " "
R14	25,000	" " " "
C1	160 μF	variable Eddystone type 1131.
C2	12 μF	" " " " 1132.
C3	See Coil Table	Dubilier metallised
C4	30 μF	air trimmer, Eddystone type 1100.
C5	30 μF	" " " " " "
C6	30 μF	" " " " " "
C7	0.1 μF	Dubilier type 691 w.
C8	0.1 μF	" " " " " "
C9	0.001 μF	" " " " " "
C10	0.1 μF	" " " " " "
C11	0.1 μF	" " " " " "
C12	4 μF	" " " " L.S.A.

C13	0.1 μF	" " " " 691 w.
C14	0.1 μF	" " " " 691 w.
C15	25 μF	Electrolytic, Dubilier type 3016.
C16	0.1 μF	Dubilier type 691 w.
C17	0.1 μF	" " " " 691 w.
C18	0.002 μF	" " " " 690 w.
C19	0.1 μF	" " " " 691 w.
C20	0.1 μF	" " " " 691 w.
C21	1 μF	" " " " 4609/S.
C22	0.005 μF	" " " " 690 w.
C23	30 μF	trimmer, Eddystone type 1023.
C24	8 μF	electrolytic, Dubilier type 9203E.
C25	18 μF	variable, Eddystone type 1094.
C26	0.01 μF	Dubilier type 690 w.
N1,2	Osglim	Neons.

Other Components .

Power Supply.
 Transformer : Varley type EP41.
 Choke : Varley 20 henry 60 mA. type D.P.51.
 Valve : Osram U12/14.
 Stabilisers : 2 Osglims (neon lamps without base resistance).
Smoothing Condensers : Dubilier electrolytic type 9203E (8 + 8 μF).
 1 Type P20 mains plug, Bulgin.
 1 Type S80T on-off switch, Bulgin.
 2 Type S104 double-pole switches, Bulgin.
 3 Small signal lamps, Bulgin D19, D33, D38.

Crystal Oscillator.

100 kc. crystal in holder, Q.C.C.
 250-turn coil, Q.C.C.
 1 V.P.41 Mazda valve.
 1 Type 1094 variable condenser, Eddystone.

Variable Oscillator.

1 Type 1131 160 μF variable condenser, Eddystone.
 7 Type 1100 air trimmers, Eddystone.
 2 Type 936 coil formers, Eddystone.
 3 Polystyrene formers.
 1 Type 1132 midget variable condenser, Eddystone.
 1 Type 210 Wearite ceramic switch.
 2 SP41 Mazda valves.
 1 Muirhead dial, type 1AV.

Mixer Stage.

1 Mazda TH41 triode-hexode.
 1 Wearite ceramic switch, type 15.
 1 Igranic telephone jack.
 1 " Clix " aerial socket.

Sundries.

3 Midget stand-off insulators, Eddystone.
 5 " Clix " valve sockets.
 3 Knobs, Eddystone type 1089.
 2 Bayonet type lamp holders.

For rigidity a strong, metal chassis is imperative and all components must be firmly secured to it. Stout wire must be used for wiring up, and if coil changing is desired it should be achieved by the use of a good quality ceramic switch, and not by handling.

If these considerations are borne in mind the design of a suitable frequency meter will be found quite straightforward.

Sub-Standards for checking Calibration

It is essential to include some form of sub-standard for frequently checking the calibration, and the most suitable form is a low frequency crystal oscillator.

A high frequency crystal is not desirable because for one thing its harmonics are so widely spaced on the frequency spectrum that it would not give a sufficient number of points at frequent intervals. The low frequency crystal on the other hand produces a large number of harmonics spread over each amateur band at intervals equal to the frequency of the crystal. In practice a 100 kc. crystal is used and this value is very convenient. If further checking points are required the crystal could be arranged to drive a suitable multivibrator and to give a point at every 10 kc. instead of every 100 kc.

It is possible to vary the frequency of the crystal slightly by connecting across it a small variable condenser of about 18 $\mu\mu\text{F}$ capacity. This will allow of small adjustments being made to the crystal frequency to match it accurately to some other sub-standard.

In order to keep an open scale of calibration and to give a greater accuracy of reading it is necessary to cover a range of frequencies in steps, rather than to work off harmonics from one calibrated range. For amateur requirements therefore it is desirable to construct an instrument having a separate range for each band, and this band to be spread over the whole dial reading.

Practical Application

Bearing all these points in mind the meter illustrated in Fig. 1 was designed and constructed.

A study of the circuit Fig. 2 will show that a Franklin oscillator has been chosen, for the reasons outlined above. A 100 kc. crystal oscillator is also incorporated and its output "mixed" with that of the Franklin, in a Triode-Hexode valve. A pair of telephones in the anode circuit enable the beat notes to be heard every 100 kc. as the frequency of the Franklin oscillator is varied.

The oscillator valves are high-slope pentodes, *Mazda* SP41's and were chosen because of the wide range of frequencies it was desired to cover. Since this type of oscillator is virtually an amplifier it is necessary to have as much "gain" as possible at the higher frequencies in order to produce adequate oscillation, and it is found that even at 14 Mc. these valves oscillate quite readily.

Five bands are covered by switching coils with a *Wearite* ceramic switch. Actually the 28 Mc. band is covered by a 14 Mc. coil with the band spread tap suitably adjusted. It is easier to make a stable 14 Mc. oscillator than one on 28 Mc. and the valves are not readily persuaded to function well at this frequency. For these reasons it was decided to operate this band from 14 Mc. harmonics.

Coil-Winding Table

Band.	Turns.	Tap from Earth End.	Loading Capacity.	Wire Gauge.
(1) 1.7 Mc.	32	32.0	300 $\mu\mu\text{F}$	22 Enam.
(2) 3.5 Mc.	15	7.0	200 $\mu\mu\text{F}$	20 Enam.
(3) 7.0 Mc.	12	4.5	100 $\mu\mu\text{F}$	18 Enam.
(4) 14.0 Mc.	7	1.5	50 $\mu\mu\text{F}$	18 Enam.
(5) 28.0 Mc.	6	3.0	50 $\mu\mu\text{F}$	18 Enam.

Coils 1 and 2 are wound with turns in slots in former.

Coils 3, 4 and 5 are wound with turns touching, adjustments later being made by slightly separating. Coil 5 is tuned with 100 $\mu\mu\text{F}$ in series.

Output Circuits

Band.	Turns.	Wire Gauge.
1	130	36 D.S.C.
2	60	32 D.S.C.
3	22	32 D.S.C.
4	8	32 D.S.C.
5	4	32 D.S.C.

Formers $\frac{1}{8}$ -in. Paxolin tube. All turns touching. Coils "flattened" with 10,000 ohms in parallel.

Tuned Circuits

Five formers are used, the two for the lower frequency bands being *Eddystone* valve base type with the pins removed, and securely bolted to the chassis. The three remaining formers are made of Polystyrene, and are mounted on the chassis by means of a small aluminium or brass bracket constructed from a small piece of angle strip.

The 3.5 Mc. coil is on the left, then the 7 Mc., and the 1.7 Mc. coil on the right. These are all mounted vertically. Next to the 1.7 Mc. coil, and mounted horizontally is the 14 Mc. coil, and next to this, and underneath the main tuning condenser, is the 28 Mc. coil, wound as previously explained, to oscillate at 14 Mc., but with the condenser tap arranged so that its harmonic covers the 28 Mc. band. It should be arranged that a small fixed condenser of 100 $\mu\mu\text{F}$, is connected in the circuit between the tap on this coil and the main tuning condenser. This is to open out the tuning on the harmonic so that a fairly open scale may be attained.

The coil turns and approximate tapping points are shown in the table. The actual tapping points will have to be found by experiment, since a very small change only is necessary to upset the band-spread effect.

The coils are loaded with a certain amount of fixed capacity, which is indicated in the table. These fixed condensers are *Dubilier* metallised mica types. It is essential that good quality condensers be used in this position, since the calibration depends partly on their stability. *Eddystone* air trimmers are used on each circuit to give the final adjustment, and once adjusted may be fixed with a little Polystyrene cement, as used on the coils.

The two coupling condensers are also air trimmers and are mounted on a strip of copper attached to a

stand-off insulator fixed to the side of the screening box. These are almost unscrewed, and when the smallest capacity, to maintain oscillation on any band, has been found, may be fixed with the Polystyrene cement.

The midget variable condenser, connected across the main tuning condenser, provides a means of setting the main dial to its calibration, despite small changes due to temperature variation, etc. Its position is made clear in the photograph.

The dial, which is extremely important, is a *Muirhead* type 1-AV. This has a vernier scale, and is to be recommended if the instrument is to be constructed with the care it deserves.

Screening Boxes and Chassis

The screening boxes and chassis are constructed of brass, and securely screwed together with 6 B.A. screws. Angle strip is used for joining the edges, and the holes in this are tapped 6 B.A. Bolts could be used if desired.

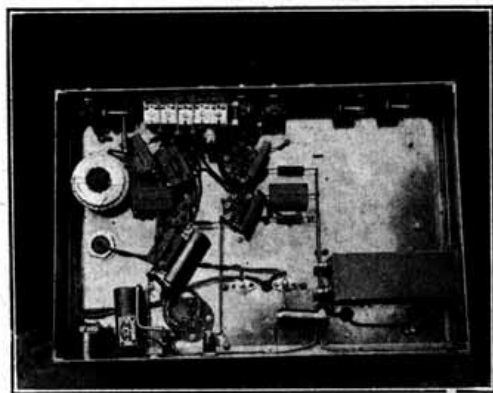

Fig. 3.

Underside view showing wiring. Note the clean layout.

The main chassis and coil box are of 16-gauge, while the valve box is 18-gauge. The two lids to the boxes are 20-gauge. The total weight of the chassis and boxes, without components is $12\frac{1}{2}$ lb. It will be seen from this that a good, rigid basis is given to the instrument, with plenty of opportunity for dissipating the heat generated. The chassis measures $15'' \times 10'' \times 2\frac{1}{2}''$ high. The coil box is $6\frac{1}{2}'' \times 6\frac{1}{2}'' \times 5''$ high, while the valve box is $5\frac{1}{2}'' \times 5\frac{1}{2}'' \times 5''$ high, and has a number of $\frac{3}{8}''$ holes drilled in the back for ventilation. Both screening boxes are mounted up to the front edge of the chassis, with the coil box on the outside. A small space of $\frac{1}{4}''$ is left between this and the valve box, so that its temperature may be affected as little as possible.

Layout

After mounting the screening boxes, the rest of the components are arranged on the chassis. The crystal and its adjusting condenser are on the left of the valve box. Behind them is the *Dubilier* electrolytic smoothing condenser, $8 + 8 \mu\text{F}$. Behind that is the transformer supplying H.T. and L.T. The rectifier valve and smoothing choke are behind the valve box, and the two neon lamps used for stabilising the H.T. supply are behind the coil box.

It will thus be seen that the crystal and coils are as remote as possible from sources of heat, and will only be warmed through conducted heat in the chassis.

Underneath the chassis the 100 kc. oscillator anode coil is mounted on a small piece of ebonite bolted to the panel, close to its respective valve-holder. The output tuned circuits are immediately below the valve box mounted on a small wooden sub-base, attached to the front of the chassis, and are selected by the *Wearite* switch mounted in that compartment.

The three switches control the A.C. input, variable oscillator and 100 kc. oscillator respectively, and the pilot lamps indicate which circuit or circuits are in operation.

At the rear of the chassis are mounted the A.C. input socket, a *Bulgin* P.20 safety type, the telephone jack and aerial socket.

Wiring

The disposition of the smaller components is rather dependant on the wiring, but they should be kept as close to their particular circuit as possible. The wiring itself should be short and rigid, except for the H.T. and L.T. leads which may be run round the sides of the chassis in the most convenient manner. The photograph in Fig. 3 shows all these details clearly.

The voltage for the screen circuits is derived from the mid-point of the two neon stabilisers. These keep the H.T. and screen volts at an almost constant value, irrespective of load, and are consequently of considerable assistance in maintaining the stability of the instrument.

Operation

When the variable oscillator and 100 kc. oscillator are both switched on and a pair of phones inserted in the jack, a beat note will be heard at every 100 kc. as the dial is rotated. The trimmer and tap of the circuit in use should be adjusted so that the extremities of the band covered fall about 5° inside each end of the dial.

It will be found advantageous to carry out the initial calibration with 10 kc. points, obtained by the use of a multivibrator used in conjunction with the 100 kc. crystal oscillator.

The adjustment of the output circuits, in the anode lead to the mixer valve, may be carried out with a valve voltmeter across each coil, or by feeding the output, *via* the aerial terminal, into a receiver fitted with an "S" meter. Since these circuits are flattened by a 10,000 ohm resistance, the adjustment will be found quite easy. Coil sizes are shown in the table. The trimmers are *Eddystone* mica type 1023.

The calibration curves for each band should be drawn in sections, so that they will not be of an undue size due to the use of an open scale; $\frac{1}{10}$ degree to one division should be used, and the sections may be kept together in a ring file.

The general stability will be found quite good if all the precautions outlined above are taken, and provided suitable time is allowed for warming up. After this a drift up to about 300 cycles per hour may be expected on the lower frequencies, and somewhat more on the higher. It will be advisable to check the variable oscillator against the fixed, if

(Continued on page 164).

THE CONSTRUCTION OF A CRYSTAL BAND PASS FILTER

By P. F. CUNDY, Grad.I.E.E. (G2MQ)

The important series of theoretical articles written by Mr. E. L. Gardiner, G6GR, dealing with Crystal Band Pass Filters, has, as anticipated, created a demand for some advice dealing with the practical introduction of a crystal filter into an existing superheterodyne receiver.

At our request the present author has kindly furnished some notes which will, it is hoped, bridge the gap between theory and application.

Preliminary Considerations

THE receiver into which the crystal filter was to be built used two I.F. stages (KTW63) with Eddystone I.F. transformers, type 1014. The layout was such that the filter could most conveniently be placed between the two I.F. valves, a position to which Mr. E. L. Gardiner makes no objection in his original article.

The actual Intermediate Frequency was determined before ordering the crystals, in the following manner: An ordinary T.R.F. broadcast receiver was made to oscillate on the long wave band by removal of the coil screens, and the aerial terminal connected through a condenser and resistance combination to the signal grid of the frequency-changer of the short-wave receiver, the T.R.F. receiver then being tuned until a strong signal was obtained on the "S" meter. A second broadcast receiver was then placed near the oscillating receiver and tuned across the medium wave band until a signal again appeared. This was found to produce a strong 500-cycle beat note on the low frequency side of the B.B.C. Home Service station (668 kc.), from which the I.F. was deduced by the following method:—

Third harmonic frequency $668 \times .5 = 667.5$ kc.

Fundamental frequency = $\frac{667.5}{3} = 222.5$ kc.

I.F. frequency (2nd harmonic) = $222.5 \times 2 = 445$ kc.

A pair of crystals with 2.75 kc. separation at 445 kc. were therefore ordered.

Filter Construction

With the sure knowledge that the first and last I.F. transformers were tuned to the finally required frequency, the coupling transformer between the two I.F. valves was removed, and from this, and a spare 1014 transformer, construction of the filter commenced. These transformers consist of a pair of "basket" solenoids of silk-covered litzendraht—each about 800 μ H tuned with two 100 μ F ceramic fixed condensers and two 65 μ F variable air trimmers. The coils are wound on a $\frac{1}{2}$ in. wooden dowel. As observations showed that the possibility of removing the coils from the dowel without damage was extremely remote, they were separated by cutting up the dowel itself, after which the short sections were drilled $\frac{1}{4}$ in. clearance and the coils

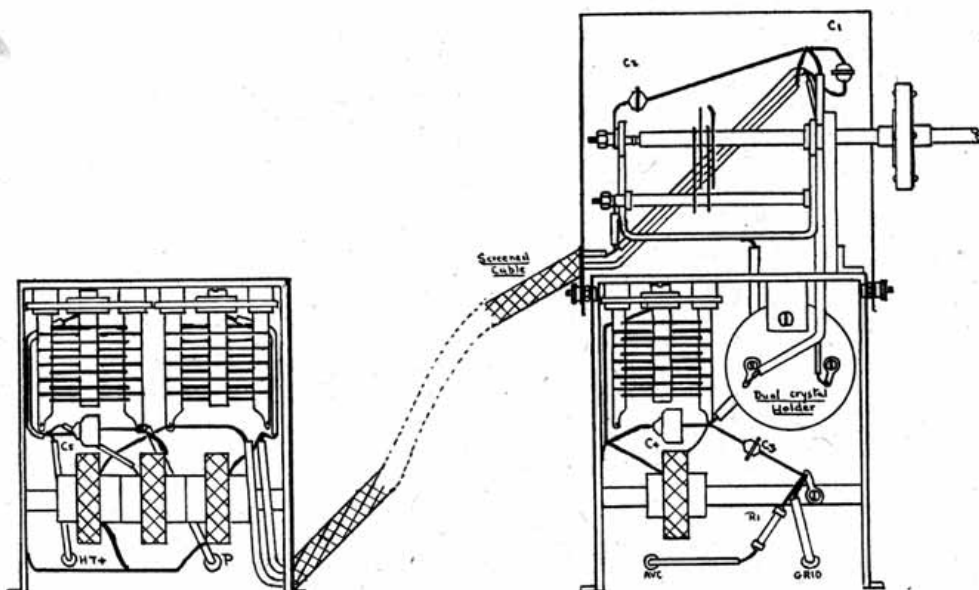

Fig. 1.
Construction of Crystal Filter.

remounted on a piece of ebonite rod, three in one transformer, and one in the other.

For the crystal input transformer, the centre coil was made the primary, and this was tuned by its original 100 $\mu\mu\text{F}$ fixed capacity plus air trimmer. The secondary was made by means of series connection of the other two. It was estimated that the capacity of the secondary leads plus the air trimmer would have been sufficient to tune to 445 kc., but this was later found not to be the case, and another 20 $\mu\mu\text{F}$ condenser (C1) was accordingly added in the second transformer.

The mounting of the various components in the output unit are clearly shown in Fig. 1. The additional screen on the top of the second 1014 transformer has all the necessary holes slotted down to the lower edge so that it can be fitted on after all wiring is complete. A virtual centre tap is obtained on the output coil by connecting the grid of the second I.F. valve through a condenser equal in value to its own grid earth capacity (C3).

Initial Results

Due to the preliminary work on frequency determination, initial alignment was easy. By tuning the oscillating B.C. receiver it was possible to plot the response curve from the "S" meter readings. Adjustment was too difficult, however, and band spread had to be fitted to the B.C. receiver. This was then calibrated in the manner already described. (Test frequency is two-thirds of zero beat frequency on the medium wave band.) The response curve, when determined, was of the form shown in Fig. 3—not at all what was required. After experiments had been made to determine if there was any I.F. coupling other than through the crystals (which there was not), the response curve was checked with the phasing condenser disconnected, when the result

took the form of Fig. 4, intimating that unbalanced minimum capacity of the phasing condenser was causing the poor result. C2 was then included to

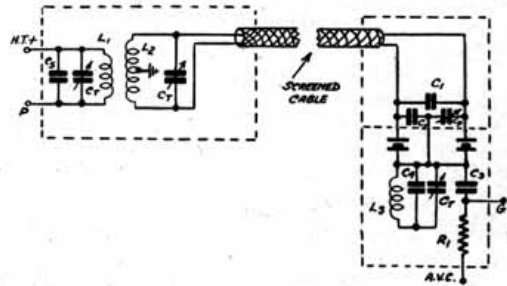

Fig. 2.

Circuit Diagram corresponding to mechanical layout of Fig. 1.

- C1 20 $\mu\mu\text{F}$ ceramic.
- C2 10 $\mu\mu\text{F}$ "
- C3 7.5 $\mu\mu\text{F}$ "
- C4 100 $\mu\mu\text{F}$ "
- C5 100 $\mu\mu\text{F}$ "
- CP 5/15 $\mu\mu\text{F}$ J.B.
- CT 65 $\mu\mu\text{F}$ max. air trimmers.
- L1 800 μH .
- L2 Two 800 μH in series.
- L3 800 μH initially; about 1,800 μH in final design.
- R1 2 megohms.

Condenser C4 was omitted in the final design.

balance this out. The bridge could now be balanced, and, when so set, all I.F. trimmers were adjusted to mid-frequency between the two crystals and the response again plotted. The curve was as Fig. 4, the dip between the two peaks being too pronounced. It was therefore decided to increase the L/C ratio of the output coil. The original coil and the 100 $\mu\mu\text{F}$ cup ceramic condenser shown in Figs. 1

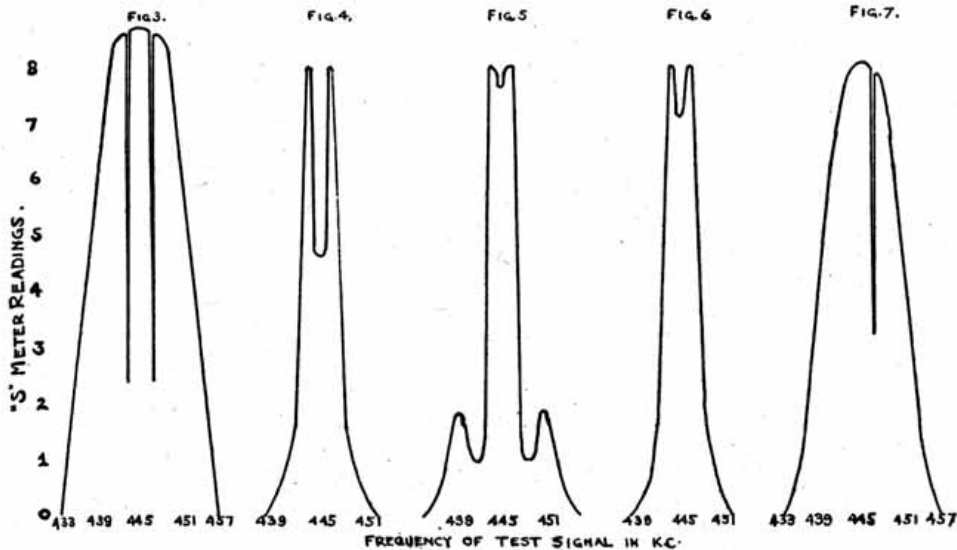

Response Curves, taken under various conditions outlined in text.

and 2 were removed and replaced by a coil of similar construction, but with an inductance of 2,000 μH (a long-wave coil from a commercial broadcast receiver). This was stripped down 20 turns at a time until it resonated with only about one-quarter of the maximum capacity of the trimmer.

Final Performance

After once more balancing the filter and re-trimming, the results shown in Figs. 5, 6 and 7 were obtained, corresponding respectively to nearly balanced, balanced, and one crystal short-circuited.

There is still a little too much dip between the peaks, but when the receiver is operated as Fig. 5 it is very satisfactory. Dust iron cores in both input and output coils would represent the final improvement.

It is necessary to bear in mind the method adopted to obtain these curves, which are modified by the A.V.C. characteristics. Unfortunately the apparatus required to plot the "classic" curves of frequency/input for 50 mW. output was not available.

The filter has, unfortunately, never been tried out under amateur operating conditions, but its satisfactory performance is confidently anticipated at some future date.

An Emergency Receiver for the Home Service

By J. H. CANT, G6FU

Beginning with an old crystal receiver salvaged from the attic, the author of this article eventually evolved a circuit which produced excellent broadcast signals without the use of a H.T. supply.

FOR some months the writer has concentrated in spare time on the design of a simple emergency broadcast receiver.

After considerable experiment a circuit was finally evolved which provided good reception of local broadcasting, using no high tension battery at all, the sole source of supply being a 2v. accumulator of the unspillable type.

The receiver is housed in a box measuring 8" \times 4" \times 4" whilst the actual components needed can be found in the junk box at most amateur stations.

Early arrangements were on more or less orthodox lines, such as, for example, a crystal detector was followed by two A.F. stages. During this particular experiment an attempt was made to use the first valve as a resistance coupled stage and quite good results were obtained in this manner. Various values of anode resistance up to 50,000 ohms were tested, but above that value the signal strength fell off and quality suffered. Next, a 3 to 1 A.F. transformer was tried in this position without any appreciable difference being noticed.

In both of these early tests the actual value of anode resistance had obviously been in the order of several thousands of ohms and on the assumption that reducing this would produce an improvement, low frequency chokes were substituted in both anode circuits, capacity coupling between stages being employed as in normal practice. With this arrangement a marked increase in gain was apparent and on both "local" stations S7 signals were received in south-east London using an odd length of wire for an indoor aerial.

This performance was at the time thought to be the maximum obtainable, but shortly afterwards it was discovered that weak signals were being received when the crystal contact was broken, indicating that partial rectification was taking place in the first valve. The crystal circuit was therefore removed as was the A.F. coupling transformer, and in their place was connected a normal tuned circuit across the grid and negative filament. The use of grid condenser and leak to V1 was found unnecessary, so the tuned circuit was taken direct to grid as for anode rectification.

Excellent signals both in regard to strength and quality were obtained with this arrangement, being

equal in all respects to those given by the earlier circuits which incorporated a crystal.

As a point of interest a few foreign broadcast stations were heard weakly.

Although it is not possible to evaluate the gain of this circuit, a series of tests were made using a General Radio signal generator delivering an input of 1 volt to the aerial and negative filament. This

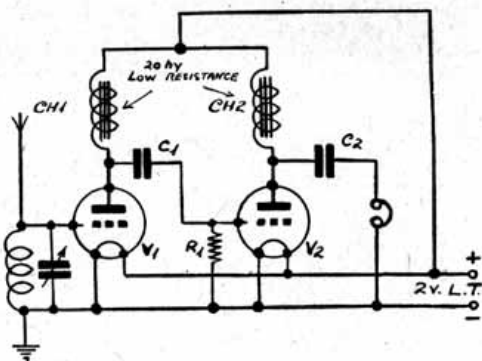

The circuit of a Two-valve Broadcast Receiver operating from a 2-volt dry accumulator.

$C_{1,2}$.0003 μF .	$CH_{1,2}$	R.I. Dux 25H.
$C_{3,4}$.1 μF .	V_1	PM1HL.
R_1	.5 meg.	V_2	P220.

gave an output of 0.2 volt A.C. as read by a Weston output meter connected directly across the output terminals. Tested over a frequency range of 1,500-600 kc. the output was constant at the above figure.

The writer will be pleased to hear from other readers who have experimented along similar lines.

Bombed Out.

Mr. D. T. Blunden, G8IN, asks us to state that due to enemy action he has been compelled to vacate his previous house. He is now living at 12, Station Approach, Chipstead, Surrey, at which address his service friends will be made very welcome.



Reg. U.S.A. Pat. Off.

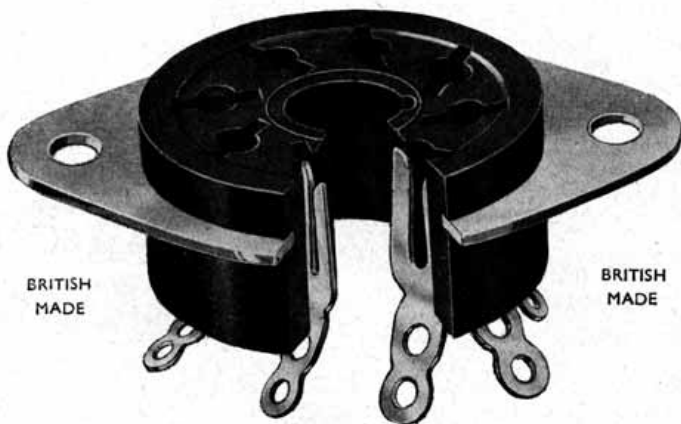

CELESTION-AMPHENOL VALVEHOLDERS

are the strongest in the World. Take note of the four important features mentioned below.

STRENGTH !

Exclusive Celestion-Amphenol method of Moulded-in Plate construction ensures maximum strength, rigidity and a high degree of efficiency. The sturdy plates are keyed into the body and cannot rattle loose.

EFFICIENCY !

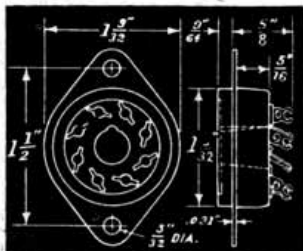

UNIFORM CONTACT !

INSULATION !

Celestion-Amphenol Contacts, pressed from specially treated phosphor-bronze, are engineered to ensure uniform contact on all prongs. Exceptional insulation is assured by the special properties of the moulding powder.

All standard British and American types in stock

CELESTION LIMITED

Engineers,

KINGSTON-UPON-THAMES, SURREY

Works: Kingston-upon-Thames, and at Ashted, Surrey

Telephone: KINGston 5656-7-8

In these days

Don't forget that your radio receiver is more important than ever—keep it at maximum efficiency. The valve is one of the most important components—do not try to operate on worn out or unsuitable types. There is a large range of OSRAM VALVES to meet every purpose—from efficient short-wave types to high power amplifiers.

NOTE—Don't Forget the Power Rectifier

If you have any difficulty in obtaining any particular valves, write to the Osram Valve Department of:

**Osram
Valves**
Made in England

THE GENERAL ELECTRIC CO., LTD., Magnet House, Kingsway, London, W.C.2

BULGIN & NATIONAL EFFORT

MENTION T. & R. BULLETIN WHEN WRITING

IN these times, in many directions, needless to say, we are directing our main efforts and supplies towards the requirements of the Government Services.

However, some supplies of components are still available for Radio Servicing, but should delays occur we know our friends will appreciate the difficulties which at present arise from day to day.

We would point out that delays can be minimised and often avoided if alternatives are specified when ordering.

Prices are being kept as low as possible despite increased costs in every direction. Meanwhile you still have the best and largest range of products in the United Kingdom to choose from.

CATALOGUE No. 163a, 6d. POST FREE
A. F. BULGIN & Co. Ltd., BYE PASS ROAD
BARKING TEL. RIPPLEWAY 3474, 4 lines

PIONEERS IN CRYSTALS for Band-pass Filters

WE can supply QUARTZ CRYSTALS to specification mounted singly in Radio Frequency low-loss moulded Ceramic holders, or in matched pairs for band-pass filter construction.

Crystals for frequencies between 440 and 480 kc., and differing by any desired frequency from 200 cycles up to 9 kilocycles can be supplied from stock. We recommend a spacing of 3 kc. for communication telephony.

PRICE: Single Mounted Crystals - £1- 7-6
Pair of Mounted Crystals (in patented double type holder) £1-17-6
(Prices + 10% War increase)

For those desiring the best performance obtainable we can also supply these crystals mounted in an IMPROVED EVACUATED MARCONI DESIGN HOLDER, manufactured by us under exclusive licence.

This holder is non-microphonic, little affected by temperature, dust or moist air, whilst reduced crystal damping ensures high selectivity and sensitivity. The unit resembles a valve and fits British 4-pin or American 5-pin valve holders.

PRICE: Per Crystal - - - £1-19-6
(+ 10% War increase)

Write for particulars to:

PIEZO CRYSTALS LTD.
11 Queen Victoria Street, London, E.C.4
Telephone: City 4144

THE W₃EDP PRESENTS ANOTHER AERIAL PROBLEM

By DONALD H. TOMLIN, B.Sc. (2HMN) *

Following up the description of the original W₃EDP Aerial which appeared in Experimental Section notes last month, the contribution here published is of special interest. Interference to broadcasting seems to be one of its major disadvantages; as against this the aerial appears to possess several important advantages. Constructive criticism of any amateur type of transmitting aerial will lead to a better understanding of aerial problems in general.

AN aerial constructed to the design of W₃EDP was in operation at G4JW prior to the "close down" and some very remarkable results were achieved with it on 7 Mc. phone. A careful note having been made of these results it soon became evident that its mode of working was not fully understood. Additionally it was found that quite a number of amateurs throughout the country were using the same type of aerial, and were in greater or less degree obtaining similar results. Of those contacted, however, not one knew how the aerial worked, and usually was still less interested, so long as it gave increased signals. Some dismissed the matter with a declaration that it was a simple Marconi and discussed it no further. We were not satisfied however and carried out a few preliminary experiments, which were cut short by the war. It is therefore desirable to list our findings up to that point and see to what extent they are in accord with the experiences of other readers and with any theories they may put forward.

When the aerial was erected, the station signal strength in the Sheffield area went down considerably, but over the whole country it increased, and was approximately the same in all directions. It should be noted that previously a half-wave aerial, end-fed, had been used.

The aerial itself was cut to length using both transmitter and field strength readings, although it was slightly longer than the size quoted in *The Amateur Radio Handbook* 1940 (page 184). It was found that the length of the counterpoise was by no means critical, indeed it did not seem to matter to a few feet. We were somewhat perturbed by the fact that no data was available concerning the function of the counterpoise but finally decided that it had definite radiating properties.

According to the *Handbook*, the counterpoise can be situated in the operating room, but must run at right angles to the main aerial. This seemed all right until we discovered that most users obtained the same results even with it coiled up on the floor, provided the full length of wire was used, and that the leads from the coupling coil were at right angles. We therefore set out to find the actual facts concerning the counterpoise.

First we found that if it was set vertically above the main aerial, still keeping the two at right angles, there was an average increase of two S points in nearly all directions. A similar increase was noted in reception, but the aerial only worked satisfactorily over a narrow band of frequencies, without re-adjustment. Other than in this position, the results were the same, no matter what was done with the wire.

Secondly, using a neon lamp, it was discovered that the voltage distribution was approximately the

same over the whole length of the counterpoise, suggesting a travelling wave. The current was the same at both ends of the coupling coil feeding the aerial and the counterpoise. When the aerial was taken down for alterations, an attempt was made to find the voltage distribution in it. But it was discovered that the maximum voltage point was approximately one-third of the way from the free end, this being 28-30 feet. The length of the aerial was 85 feet 2 inches.

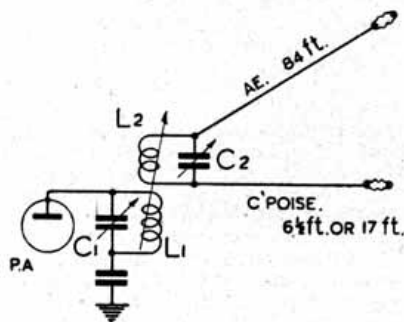

The W₃EDP Multi-Band Aerial.

Band. Mc.	C'pse. Feet.	L2—2" Diam.
3.5	17	21 turns 16 S.W.G. spaced one diam.
7	17	7 turns 16 S.W.G. spaced one diam.
14	6½	5 turns 16 S.W.G. spaced one diam.
28	0	3 turns 1" spacing.

The puzzling part of the matter was that the particular system did not work well on 14 Mc. except as a directional aerial, being best in the direction in which it pointed.

Having said our piece, we now ask the question: "How did the aerial function on the various wave-bands for which results were claimed?" The actual length, and the wave-length on which it could be used, formed some weird and wonderful ratios and certainly resembled no other aerial. Remember, we are not decrying the aerial, in fact we actually obtained extremely good results with it. Completely exasperated, we wrote to W₃EDP himself, but no reply was received!

The only drawback to the aerial was that it caused a considerable amount of BCL interference, and this has been confirmed by all who were contacted using the same arrangement.

The actual experiences of those who have tried the W₃EDP may perhaps help towards a solution.

* In collaboration with J. R. Petty (G4JW), Sheffield.

MATHEMATICS FOR THE RADIO AMATEUR

By T. R. THEAKSTON, B.Sc. (2DBK).

PART II.—COMMONLY USED FORMULAE

Ohm's Law and its Applications To Bias Problems and Resistances

Solutions to Problems set in Part I

No. 1. (a) **2.0933 ohms**; (b) **9950 ohms**. No. 2. (a) **300 ohms**; (b) two of the 200 ohm resistances should be connected in parallel and this combination then joined in series with another 200 ohm resistance. No. 3. (a) **0.00009 μF**; (b) **0.0011 μF**. These answers are collected here for reference; the full solutions will be given in the relevant places in the text below.

$$\begin{aligned} \text{No. 4. } & \frac{10^6}{6.28 \times 3500 \times 10^3 \times 0.001} = \\ & \frac{10^6}{628 \times 35 \times 1} = \frac{10^6}{18840 + 3140} = \frac{10^6}{21980} = 2198. \end{aligned}$$

On evaluation of this example by long division, or by logarithms, the answer is found to be **45.5**.

Notes.—(1) Always simplify initially as far as possible, especially to remove the decimals from the denominator.

(2) Logs could be used to evaluate directly from the second expression.

(3) Unknowingly perhaps, in working out this calculation, the reader has found that the reactance of a condenser of 0.001 μF. is **45.5 ohms** at a frequency of 3.5 Mc. per sec. For $X = 10^6 / (2\pi \times f \times C)$, where X = capacitive reactance, in ohms, of a condenser of C μF., at a frequency of f cycles per sec.; and where $2\pi = 6.28$.

No. 5. $\sqrt{(70.5)^2 + 125^2}$. The following methods can be used to evaluate this expression:—(a) Square 70.5 and 125 by ordinary multiplication, add, and extract the square root arithmetically. This gives:—

$$\begin{aligned} \text{Expression} &= \sqrt{4970.25 + 15625} \\ &= \sqrt{20595.25} \\ &= \mathbf{143.5.} \end{aligned}$$

(b) Use tables which give squares and square roots. Such tables are a very useful adjunct to calculations.

$$\begin{aligned} \text{This method gives } E. &= \sqrt{4970.3 + 15625} \\ &= \mathbf{143.5.} \end{aligned}$$

(c) Square each term by logs, add, and evaluate square root by logs. This gives

$$\begin{aligned} E. &= \sqrt{\text{antilog}(3.69638) + \text{antilog}(4.19382)} \\ &= \sqrt{4970.2 + 15625} \\ &= \text{antilog}(\frac{1}{2} \log 20595.2) \\ &= \text{antilog}(2.156875) \\ &= \mathbf{143.51.} \end{aligned}$$

Notes.—(1) It can be seen that from the point of accuracy all methods are alike. But for ease of working (b) is the best.

(2) Here the reader has worked out another electrical calculation. He has in fact found that the total impedance of a circuit of 70.5 ohms reactance and 125 ohms resistance = **143.5 ohms**. For $Z = \sqrt{R^2 + X^2}$, where Z = impedance, R = resistance and X = the reactance of a circuit (all the quantities are in ohms).

Ohm's Law

This law, connecting voltage, current and resistance, is of fundamental importance, and for that reason it should be thoroughly familiar to every radio experimenter. The author proposes, therefore, to devote the whole of this section to the consideration, particular and general, of its application.

The law states:—“If a current of I amperes is passing through a conductor of R ohms resistance, across the ends of which a potential difference of E volts is maintained, then $E = I \times R$.”

$$E = I \times R; \quad I = E/R; \quad R = E/I.$$

It must be remembered:—

(1) This law applies to *direct* current. When alternating current is used, Impedance (*i.e.* the effect of reactance and resistance) must be considered. If this Impedance is denoted by Z , the law for A.C. can be expressed as $E = I \times Z$. This will be dealt with in a later article. But it may be mentioned here, however, that when wires are *short*, such as the A.C. filament supply leads to a valve, they can be considered as being pure resistances, and Ohm's law will apply. For example:—A 4-volt valve which requires a filament current of 1 A. is to be run from a 6.3 volt supply. A resistance in series with the filament is required and it **must** give a voltage drop of 2.3 volts. The resistance = $E/I = 2.3 \div 1 = 2.3$ ohms. This, incidentally, could be made from 76 inches of 22 S.W.G. Eureka wire, which has a resistance of 1.093 ohms per yard and a current carrying capacity of 1.5 amps.

(2) In the formula $E = I/R$, E is in volts, R in ohms and I in *amperes*. Hence, as is most frequently the case in amateur radio, when current is in mA. its value must be expressed in amperes by dividing by 1000.

Application to Bias Problems

Grid Leak Bias.—If bias is obtained by using a grid leak, then the voltage drop across it, due to the passage of D.C. grid current is the bias voltage. By applying Ohm's law to the leak, we have

$$V_g = I_g \times R_g,$$

where R_g is grid leak resistance, V_g is bias voltage and I_g is the D.C. grid current under operating conditions. The problem is usually to find the necessary value of resistance to give a definite bias voltage. In that case the formula, by transposition becomes

$$R_g = V_g/I_g.$$

If, to safeguard the valve should excitation fail, a combination of battery and leak bias is used, then if E is the voltage of the battery

$$R_g = (V_g - E)/I_g.$$

Cathode Bias.—Here again the bias voltage is the voltage drop across the bias resistance; but it must be remembered that the whole of the current

(anode, screen and grid) passes through the resistance. Therefore:—

$$R_g = V_g / (I_a + I_s + I_g).$$

Thus in problem 2 (a) set last month, $I_a = 36$ mA. $I_s = 9$ mA.; $I_g = 0$; $V_g = 13\frac{1}{2}$ volts.

$$\begin{aligned} \therefore R_g &= 13.5 / \frac{(36 + 9)}{1000} \\ &= \frac{13.5 \times 1000}{45} \\ &= 300 \text{ ohms.} \end{aligned}$$

The term "1000" is introduced, as the formula requires current to be expressed in amperes.

The datum needed to calculate the value of the necessary resistance is obtained from the figures given by the manufacturer. The bias voltage required in Class A operation is the mid-point bias value. For Class B operation, bias to "cut-off" is required, and this is found by dividing the anode voltage of the valve by its amplification factor; i.e. for "cut-off" $V_g = E_a/\mu$. When running in Class C the bias voltage should be at least twice the "cut-off value" found as above.

Illustrative example.—If for a valve of the PX 25 type for which the amplification factor $\mu = 8$, the following are operating conditions, the value of the cathode or grid resistances would be calculated as shown. With grid resistances the value is by no means critical and so the theoretical value could be taken as a minimum.

(a) For A.F. operation:— $E_a =$ anode voltage = 400; $I_a =$ anode current = 40 mA.; $V_g =$ bias voltage = less than $E_a/\mu = -30$ volts.

$$\therefore \text{Cathode } R. = V_g/I_a = 30/0.04 = 750 \text{ ohms.}$$

(b) For R.F. Class A operation:— $E_a = 500$; $I_a = 50$ mA.; $V_g = -50$ volts; $I_g =$ grid current = 10 mA.

$$\begin{aligned} \therefore \text{Cathode } R. &= V_g/(I_a + I_g) = 50/0.06 = 850 \text{ ohms (approx.)} \\ \text{or Grid } R. &= V_g/I_g = 50/0.01 = 5000 \text{ ohms.} \end{aligned}$$

(c) For R.F. Class B operation:— $E_a = 500$ volts; $I_a = 80$ mA.; $I_g = 14$ mA.; $V_g =$ "cut-off" value = $E_a/\mu = 500/8 = -62.5$ volts.

$$\begin{aligned} \therefore \text{Cathode } R. &= V_g/(I_a + I_g) = 62.5/0.094 = 665 \text{ ohms (approx.)} \\ \text{or Grid } R. &= V_g/I_g = 62.5/0.014 = 4457 \text{ ohms.} \end{aligned}$$

(d) For R.F. Class C operation:— $E_a = 500$ volts; $I_a = 100$ mA.; $I_g = 15$ mA.; $V_g =$ at least twice "cut-off" value = -130 volts.

$$\begin{aligned} \therefore \text{Cathode } R. &= V_g/(I_a + I_g) = 130/0.115 = 1130 \text{ ohms, or Grid } R. = V_g/I_g = 130/0.015 = 8700 \text{ ohms (approx.).} \end{aligned}$$

Application to Combinations of Resistances

(a) *Resistances in Series.*—If R_1 and R_2 , Fig. 1A, are in series, i.e. are connected so that the total current I traverses them both, then by applying Ohm's law to each in turn, voltage drop across $R_1 = E_1 = I \times R_1$, and voltage drop across $R_2 = E_2 = I \times R_2$. Hence $E_1 + E_2 = I \times (R_1 + R_2)$. . . (a). But $E_1 + E_2 =$ total voltage drop across AB, and if R is a single resistance equivalent to the two resistances in series, then $E_1 + E_2 = I \times R$. Comparing this with (a) above it is seen that $R = R_1 + R_2$. And so for any number, n , resistances, $R = R_1 + R_2 + R_3 + \dots + R_n$.

(b) *Resistances in Parallel.*—If R_1 and R_2 , Fig. 1B, are two resistances in parallel, then the total current I is divided into two parts I_1 and I_2 , where $I_1 + I_2 = I$. Applying Ohm's law to each resistance, if E is the P.D. across the resistances (it is clearly the same for both), $I_1 = E/R_1$ and $I_2 = E/R_2$. Hence

$$I_1 + I_2 = E \left(\frac{1}{R_1} + \frac{1}{R_2} \right) \dots (a). \text{ If } R \text{ is the single}$$

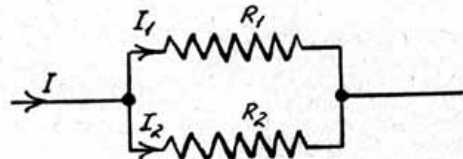
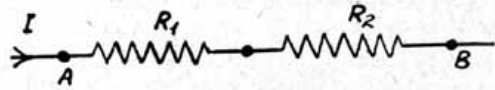

Fig. 1

The application of Ohm's Law to resistances in series (a) and parallel (b)

resistance equivalent to R_1 and R_2 in parallel, then $I = I_1 + I_2 = \frac{E}{R}$, and comparing with (a) it is seen

that $\frac{1}{R} = \frac{1}{R_1} + \frac{1}{R_2}$; and so for any number, n , of resistances in parallel

$$\frac{1}{R} = \frac{1}{R_1} + \frac{1}{R_2} + \frac{1}{R_3} + \dots + \frac{1}{R_n}$$

Notes.—(1) The resulting resistance of a number of resistances in parallel must be less than any one of the individual resistances.

(2) A useful form of the formula can be found when considering two resistances in parallel. For

$$\frac{1}{R} = \frac{1}{R_1} + \frac{1}{R_2} = \frac{R_1 + R_2}{R_1 \times R_2}$$

$$\therefore R = \frac{R_1 \times R_2}{R_1 + R_2}$$

Illustrative example.—In problem No. 2 (last month) it was found (see above) that a bias resistance of 300 ohms was required; and further, this value had to be obtained by using the only resistances available which were all 200 ohms. This situation, apart from the problem values, could arise, and could be solved by using the above formulae.

Consider joining the resistances in parallel.

For two resistances of 200 ohms so joined,

$$R = \frac{200 \times 200}{200 + 200} = 100 \text{ ohms.}$$

(In other words, joining two equal resistances in parallel gives a value of half the original. Similarly, joining three would give a value of one-third of the original, etc.). Therefore, if to the value of 100 ohms so obtained, 200 ohms are added by putting one of the available resistances in series, the required value of 300 ohms is obtained.

(To be continued next month.)

112—224Mc OPERATING HINTS

By E. H. CONKLIN (W9BNX).*

We are again privileged to publish, with the kind permission of the Editor of "Radio" and with the agreement of the author, further important information concerning ultra-high frequency operation.

WITH an increasing interest being shown in the ultra-high frequencies, readers may welcome some ideas on the construction and operation of u.h.f. power oscillators which will remove the dangerous high voltage from the plate circuit, eliminate the need for filament chokes, improve frequency stability, and help to obtain good performance.

Removing Power from Grid Pipes

If the power supply negative is disconnected from chassis and earth, it becomes very difficult to "get across" the high voltage unless the negative is exposed—all arguments to the contrary notwithstanding. Unless grid lines are used without isolating them from the bias circuit, however, very little is accomplished by such an unorthodox suggestion. The D.C. connection to these lines, too, can be eliminated without difficulty.

The fundamental push-pull oscillator circuit is shown in Fig. 1 from which it can be seen that a large mass of metal is connected to both sides of the high voltage supply. This means that the apparatus should not be approached with the power applied, even to adjust shorting bars. It is much easier to isolate the negative than the positive, by earthing the negative to the chassis only, through a high voltage by-pass condenser. There are at least two ways of taking power off the grid lines; first by using grid condensers and separate grid leaks, and secondly by running insulated D.C. bias leads inside the grid pipes. These methods are shown in Fig. 2. It will be seen that the need to insulate the line from the chassis is completely eliminated in either case. Drilling holes in the grid pipes may be troublesome, in which case the bias leads can with the same effect be run close to and alongside the pipes rather than within them.

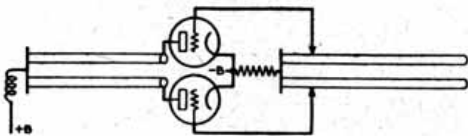

Fig. 1.

Fundamental push-pull oscillator circuit.

Removing Power from Plate Pipes

A similar idea is easily applicable to the plate lines, as shown in Fig. 3. This arrangement allows the plate pipes to be bent down to the chassis and secured there, making possible a vertical coupling hairpin which can be mounted conveniently on the chassis rather than up in the air. A sliding shorting bar is unnecessary when the lines are deliberately made short and are loaded slightly with a two-plate condenser which, incidentally, facilitates adjustment. The r.f. path between the lines, in any event, should be copper or copper-plated metal. Silver is better, aluminium nearly as good, but brass is taboo.

Pipe Spacing

A line which approximately resonates with the output capacity of the valve can be adjusted by altering the pipe spacing—rather than by moving a shorting bar—because a given capacity has a greater loading effect on a more widely spaced line. A disadvantage of wide spacing, of course, is radiation of power within the room. How great this radiation can be is readily illustrated by the ease of coupling-out the power by means of a "hairpin," coupled only to the shorting bar.

Pipe Line Design and Frequency Control

A transmission line circuit, in which the valve elements are connected to the "hot" end of the

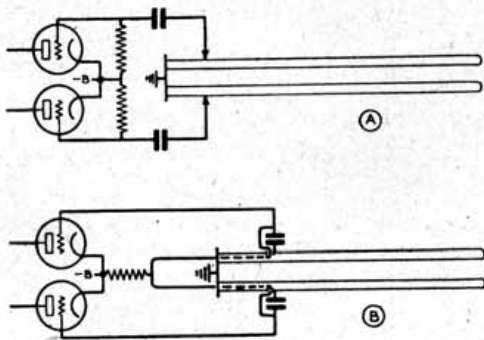

Fig. 2.

Alternative methods of obtaining D.C. grid bias when using earthed grid lines.

line, or otherwise load the resonant circuit with the equivalent of a low resistance, cannot build up a high impedance with the valve in operation. This suggests that an attempt to use lines closely approaching a quarter wavelength, or made of large diameter pipe, may in many cases be uneconomical. For instance, if the grid line can be made to control the frequency, with the grids tapped far down the line, large plate rods will probably add very little to the efficiency or stability of the oscillator. On the other hand, when the plate line controls the frequency, a grid line may be no better than a coil. Plate tuning becomes much more critical when a grid coil is replaced with a good line, limiting operation to a much smaller range of plate circuit tuning. Some effect on frequency will remain, of course, but careful adjustment will result in a sharper signal, capable of heavier modulation without spreading over a good proportion of the band.

The taps on the grid lines, as well as the grid and other r.f. leads, should be made with thin copper strip or tubing in order to reduce inductance. Some transmitters are controlled by the plate lines until the connection from the valves to the grid line taps are made with short pieces of copper strip.

* Associate Editor "Radio"

Filament Circuits

As the frequency is raised, the length of a wire in terms of wavelength becomes more appreciable. It may be possible no longer to connect the filament leads of two valves in such a way that the filaments are at earth potential, and with no impedance between them. This may introduce hum and may make impossible either perfect neutralisation or a 100 per cent. modulation capability in an amplifier, and may seriously affect the operation of an oscillator. In general, the larger the valves and higher the frequency, the more necessary filament chokes or lines will become. The use of chokes in each filament

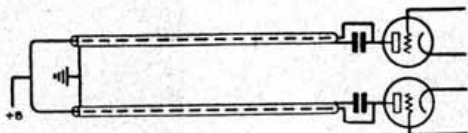

Fig. 3.

Method of removing plate voltage from plate pipes and eliminating the necessity of insulating them from the chassis.

lead was suggested some time ago. More recently, commercial television requirements have led to the development of lines in the filament circuit, electrically a half wavelength long, so that the earth point on the shorting bar is reflected to the centre of each filament. The circuit is shown in Fig. 4. Each cathode is connected to the end of a pipe and an insulated wire inside the pipe carries one side of the filament circuit. The other connection is fed either on the pipe or on a second insulated wire inside. The length of the rods will be considerably less than a half wavelength due to the reactance of the filaments and their leads. Wider spacing between the rods will permit them to be shorter, due to the greater loading effect upon higher surge impedance lines. The rods can be folded back for convenience. In one amplifier used by RCA, rods are employed which run in different directions along a metal chassis.

In some amateur equipments, the three sets of lines (grid, plate and filament) have been reduced to two by earthing the grids and using roughly quarter rather than half wavelength lines in the filament. This moves the grid tuned circuit around to the filament but apparently does not remove the resistance loading effect of the valve input circuit, which is then connected across the whole grid (filament) line. Maximum stability, therefore, may not be obtainable with this method. Furthermore, the same problem of grid lead impedance may lead to the application of the former half wavelength filament lines to the grid circuit!

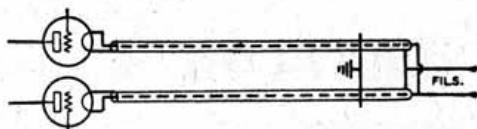

Fig. 4.

An arrangement for using a shortened half-wave line in filament circuit instead of R.F. chokes.

Pipe Line Material

The copper tubing required by a u.h.f. oscillator may deter the isolated amateur from constructing an auxiliary u.h.f. rig. Rain spouting and plumbing tubing may not be available, but often sheet copper can be obtained. Two parallel strips of sheet metal are cheaper than tubing, but are more susceptible to mechanical vibration which might modulate the transmitter. If the edge of the strip is bent to form an L-shaped cross section, the strength will be improved materially.

Oscillator Adjustment

In adjusting an oscillator for a good note and for stability under conditions of changing plate voltage (modulation), a 5 or 10 metre superhet is very useful. It is amazing how poor some signals sound on a good superhet equipped with a beat oscillator, and how much they drift. Often, they are heavily modulated with A.C. hum.

Neon Tubes

Some interesting points about neon bulbs which help in adjusting a transmitter have been noticed. When these bulbs are used on a 60 cycle power supply they glow orange over a large part of their interior. As the frequency is raised, the light becomes blue with a bright pink spot at the point where the bulb is nearest to the r.f. In fact, at 10 centimetres, the glow is almost entirely blue. This effect can be used to detect "squegging" and other low frequency parasitic effects in the oscillator. Sometimes, when the set is adjusted for best output, the neon bulb glows orange, but if the plate tuning is changed slightly, the glow may become pink and blue, and the hum modulation disappears from the carrier.

THE INCORPORATED
RADIO SOCIETY OF GREAT BRITAIN
"THE T. & R. BULLETIN"
THE OFFICIAL JOURNAL OF THE SOCIETY

Please address reply to

MEMBERS CORRESPONDENCE

TOWER BOND

MEMBERS NOTE-PAPER

3/-

PER PACKET

100 SHEETS

OVERPRINTED WITH NAME,
ADDRESS, CALL SIGN AND
TELEPHONE NUMBER

8/-



Presenting-

the **EDDYSTONE 358**

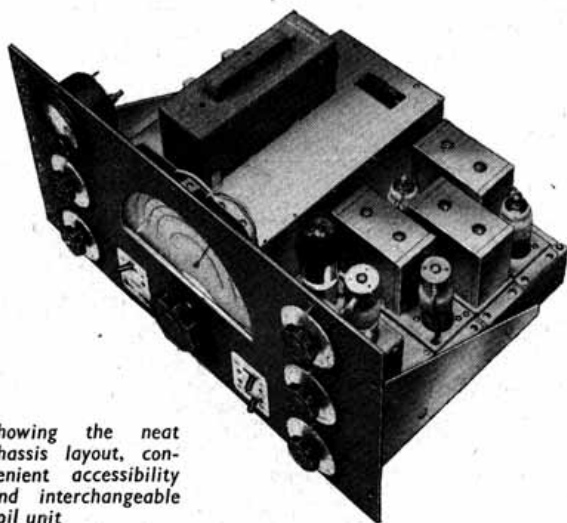

Showing the neat chassis layout, convenient accessibility and interchangeable coil unit

Attention is drawn to a new "EDDYSTONE" Production—the 358 Communication Receiver—a first-class engineering job embodying all essential features of a dependable Communication Instrument.

Based on proved design the 358 gives a high performance and its reliability is calculated to meet the exacting requirements of Service operation. It is eminently suitable for general communication purposes and is the product of en-

SPECI

Tuning range of 31,000 Kc/s to 1,250 Kc/s by the use of interchangeable range units (additional coil units will shortly be available to extend the range to 100 Kc/s)

Power supply—A.C. mains (200-250 volts) for which a power unit giving 6 volts 1.4 amperes and 175/180 volts 65mA is provided. (Later it is hoped to offer the 358 to work from a 6-volt accumulator input.)

Chassis of unit construction permitting ease of service. Housed in welded steel cabinet, ripple grey finish.

Dimensions : 20½" by 12" by 13½" deep.

Weight : 50½ lb.

Selectivity : I.F. total band width :—Two kilocycles at 2.5db down. Ten kilocycles at 40db down.

Sensitivity :—Better than 3 microvolts: 30% modulation for 50 milliwatts output on all ranges.

Audio Output :—1.5 watts.

Image Ratio :—

At 30 megacycles	20/1
" 12 "	100/1

ENQUIRIES ARE INVITED FROM GOVERNMENT OR PERSONS ENGAGED ON

STRATTON & CO. LTD
BIRMINGHAM

Telephone: MIDLAND 3771



COMMUNICATION RECEIVER

Engineers with wide practical experience of communication work. The 358 is the progressive development of previous well-known "EDDYSTONE" Receivers—it is designed to do a particular job of work—and to do it consistently well. When absolute reliability and outstanding performance are demanded the "EDDYSTONE" 358 will be found most fitting to the need—a fact given emphatic point by the orders already placed by Government Departments.

CAUTION

Image Ratio.—

At 19 megacycles	210/1 (Range "B")
" 4-5 "	500/1
" 3 "	500/1
" 2 "	1,500/1 (Range "D")
" 1-6 "	8,000/1
" 1-2 "	10,000/1

Frequency Ranges of Coil Units are :—

Range A	...	22,000	31,000 KC/S.
" B	...	9,000	22,000 "
" C	...	4,500	9,000 "
" D	...	2,100	4,500 "
" E	...	1,250	2,100 "

Output Circuit incorporates twin jacks for 120-ohm or 2000-ohm Head-phones (Other Impedances can be fitted to order).

To simplify maintenance a meter and test switch are fitted by which the emission of each valve can be checked while in position.

GOVERNMENT DEPARTMENTS AND ALL UNDERTAKINGS
 OF NATIONAL IMPORTANCE
10, BROMSGROVE STREET
BIRMINGHAM
 Telegrams: 'Stratnoid, Birmingham'



Illustrating the extremely convenient accessibility of the Eddystone 358

EXPERIMENTAL SECTION

Manager : A. M. H. FERGUS (G2ZC)

IN offering our congratulations to the R.A.F. upon acquiring the services of Mr. E. J. Williams, G2XC, we cannot but express our personal regret that he has been compelled to relinquish his leadership of our most technical Group—Propagation.

Ted Williams, took over the control of "Props" when the Experimental Section was re-organised in Sept. 1939, and from that time onwards he has given us of his best. By helpful advice to the members of his sub-groups, by the inauguration of "Cosmic Notes," by intense enthusiasm in his letter budgets and above all by the weight of his pen in presenting valuable collated information, G2XC has done more than anyone else in recent years to place this Section in the limelight.

We have every confidence in his ability to give to his country that same measure of technical brilliance which has marked his work as our Propagation Group Manager, and we wish him well.

It is early days yet to name his successor, but we have every reason to believe that his co-worker and close friend Denis Heightman, G6DH of Clacton will, like the good trouser he has always been, step into the breach. G6DH is a busy man and may not have quite the same facilities to-day as in peacetime for guiding the destinies of the Propagation Group, but we are confident that if he can take charge, the fine work started by G2XC will be continued to the very best of his ability.

Whether or not G6DH can undertake to prepare "Cosmic Notes," must be left for his decision, but in view of their value we hope it will be possible for them to appear regularly.

We hope to make further announcements next month in this connection.

* * *

The unique series of experiments which Mr. Heap records in his notes will, we have little doubt, interest many readers in and out of this Section. Incidentally, we recently saw an example of a gadget which is designed to provide a miniature light from the house mains. A small step down transformer is fitted into a suitable container and a 4v bulb connected to the secondary. We have not tested the idea, but the member who showed it to us reported very favourably on its performance. It would seem that Mr. Heap and his colleague have improved on the transformer idea.

We are particularly glad to see new ground being broken, even if it has no direct bearing on Experimental Section work in the fullest sense. G2ZC.

Aerial Group.

A great deal of interest is being shown in direction finding and as it is likely to present a field for much experimental work in the future the following brief summary of an article by James E. Bruning W3EZ in the August, 1940, issue of QST (page 19) is thought to be worth recording.

Radio Direction Finding.

At frequencies above 1500 kc., the ground wave attenuates rapidly and is of little importance except for local radiation. All waves independent of frequency vary their direction of travel, which increases

as the wavelength is decreased. Receiving equipment is influenced by other waves travelling longer paths, as well as by the main wave, while the strength of signal relies on frequency, ionosphere conditions and the angle at which the waves enter the ionised regions. As radio waves propagate from the transmitter along a great circle route they can be used in direction finding. A large loop of copper or aluminium with a few turns of insulated wire wound within the tube is used (Fig. 1.). When the plane of the loop is parallel to the direction of wave travel, voltage is maximum. As the loop is rotated, signals drop gradually to a well defined null point, which is used to determine the unknown direction—(the loop is tuned by a variable condenser). A link of one or more turns placed near the loop coil is connected to a low impedance twisted pair feed line to the receiver.

This aerial gives the bearing-angle of passing radio waves but leaves an uncertainty of 180° to the direction of the transmitter—called the bi-lateral. The "sense" of the bearing can be found by the use of a vertical aerial in conjunction with the loop. The polarity of the resultant voltage acting round the loop depends on the direction from which waves arrive, so if a small pick-up from a non-directional

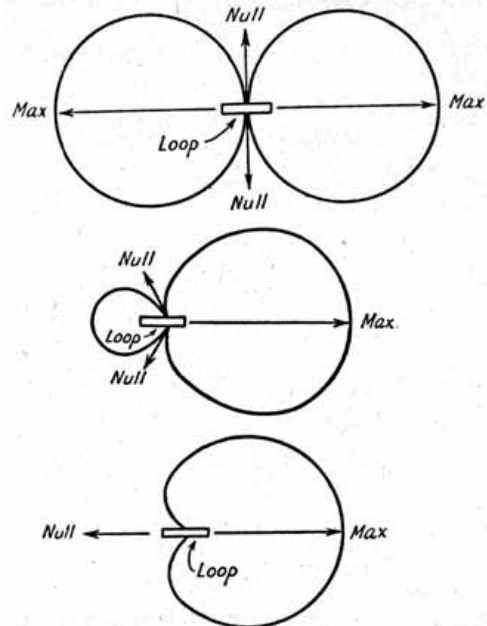

Fig. 1 (Top).—Directional characteristic of plain loop aerial. Fig. 2 (Centre).—The loop characteristic modified by the introduction of some slight additional pick-up from a vertical aerial. Fig. 3 (Bottom).—The cardioid pattern obtained when the pick-up from the loop and aerial effects are equal.

vertical aerial is coupled to the loop it will form a loop pattern as shown in Fig. 2. When two forms of pick-up are of the same strength the directional pattern becomes a cardioid (Fig. 3.).

For direction finding a preliminary bearing is taken by setting the loop for minimum response with the "sense" aerial disconnected, the uncertainty of 180° in bearing is then removed by rotating the loop 90° in the specified direction and coupling the "sense" aerial to the loop circuit. Increase or decrease of signal indicates "sense" of direction. The reader is referred to the original article for the circuit.

Errors are liable due to proximity of metal objects, wires, phones, etc., and to night effects. Compass readings also require care. True North is the direction of the North Geographic Pole. Magnetic compasses usually point to the North Magnetic Pole located in Canada, whilst maps are usually drawn on the basis of true North. GM3OM.

Receiver Group.

Our subject this month is rather off the track of receivers, but is nevertheless, of interest to nearly all amateurs, even those whose effort at home constructing has never gone beyond the standard "one-valver" of school days. The G.M. has recently been experimenting with condensers of the paper and mica type and although such experiments really belong to the "nursery" (because of their simplicity) the results obtained, seem worth recording.

It was thought that a very useful addition to the home would be a transformer of very small dimensions which could be plugged into an ordinary light socket: the secondary to be wound so that an ordinary flash lamp bulb could be connected to it, and just light to full brilliancy. Design difficulties were, however, such as to make the idea impracticable if an extremely small unit was to result. Eventually BRS1375 hit on the "bright idea" of using a condenser in series with the mains and a flash-lamp bulb. For a 6 volt bulb a 4 μ F condenser, and for a 2.5 to 3.0 volt bulb a 2 μ F condenser were found to give satisfaction. A 50,000 ohm carbon resistor placed across the condenser terminals will prevent the bulb from blowing if the light is quickly switched on and off. For an ordinary 25 watt lamp, a 1 μ F condenser, and for a 60 watt lamp a 2 μ F condenser gives sufficient current to light the bulbs to about half brilliance. Obviously the 2.5 volt bulb is the most economical and with a good reflector gives an excellent light for passages, shelters, etc. In this case the total power consumed will be less than one watt!

When used in this way the condenser may be looked upon as a current limiting device, for even if the bulb is short-circuited the fuses will not blow as the maximum current which can flow is limited by the value of the condenser capacity.

Another use for the idea is in the primary circuit of any mains transformer, but in particular it was tried, instead of a lamp, in series with the primary of a breakdown testing transformer. Its advantage over the lamp is that it presents negligible impedance, whereas the lamp produces a definite voltage drop due to its resistance and the transformer magnetising currents passing through it. The size of condenser can be chosen so that under short-circuit conditions no damage can result to transformer or house wiring.

This idea has been definitely tried and proved to be satisfactory.

Following on the last experiment the next obvious step is to place a condenser in the house wiring leads, or at any rate in the shack leads. A 4 μ F condenser (2 μ F in each lead) will save shocks in the fuse box whilst a short circuit will not harm the house wiring even if unrepaired for many hours. The amount of current taken off each wire is limited to low power apparatus but the advantages must be obvious. One word of caution should be added; don't use a condenser to replace a fuse, because it may not last for ever!

A further experiment which has not been thoroughly examined is to use a condenser in series with a valve filament. How many times have we found that we want to use a valve which has a filament voltage different to the rest in the set and that there is no tapping on the transformer to do the job? A series resistor is a nuisance and sooner or later touches a wax-filled condenser with disastrous results. No promises can be made here on the suitability of using condensers, but tests on battery valves have been very promising. It is to be hoped that readers will try out this and similar ideas and then write to the G.M.

One last warning! Use only condensers which are stamped as having high test and working voltages (1500 volts test and 500 volts working) and if possible use only those made by reputable firms. Frequently a short test on a flash-lamp bulb will pass, but when the condenser has been left on for hours, the insulation may heat up, the leakage current increase out of all bounds, and the lamp ultimately blow up.

Here's luck to all who may find time to try out these ideas, and don't forget to write up your results. G5HF.

September "QST."

It would appear that a goodly proportion of the September issue of *QST* dispatched to home members has been lost by enemy action. Those who failed to receive their copy should write direct to the A.R.R.L., 38 La Salle Road, West Hartford, Conn, U.S.A. Headquarters carries no stock and therefore is unable to help on this occasion.

Condolences.

News has just reached us that Mrs. J. S. Nicholson, wife of our South India Representative, VU2JP, succumbed last May to typhoid fever. On behalf of the very large number of home and Empire members who have had the pleasure of meeting Mr. Nicholson, either in person or over the air, we record this expression of our sincere condolences.

* * *

Deepest sympathies are also extended to Mr. L. Herrington, G5QL, who lost his wife and only child when his home in Surrey received a direct hit. G5QL is serving as a wireless operator in the R.A.F.

**MENTION THIS JOURNAL WHEN
WRITING TO OUR ADVERTISERS.
— THANKS. —**

KHAKI AND BLUE

Items for inclusion in this exclusive feature should reach the Secretary-Editor not later than the first day of the month preceding date of publication.

Friends of Jim Turner, G6LU, will be interested to learn that he is now a Corporal Instructor in the R.A.F., located at a Signal School in Victoria, Australia. During the past six months he has had the pleasure of meeting well over 50 VK amateurs, and has attended several meetings of the W.I.A. at Melbourne. On one occasion he had his voice recorded because some of those present were longing for the sound of DX! Jim is receiving expert instruction in the use of bug keys from an ex-newspaper operator.

Although his own copy of THE BULLETIN is delayed in reaching him he reads home news by a perusal of copies sent direct to Australia. He estimates that 60 per cent. of the R.A.A.F. personnel are hams.



Monty Campbell, (G8MK), well known to members of the Thames Valley Society, is now a Lance-Corporal in the R. C. of Signals.

F./Sgt. A. P. Morgan, R.A.F., G8DV, late of Golders Green, and now with a home address at "Woodlands," Gorelands Lane, Chalfont St. Giles, Bucks, tells us that he joined the R.A.F. as a wireless operator in 1935 and more recently has been serving as a pilot in the Coastal Command.

Sgt. G. W. Hicks, G4JP, who is with the 165th Infantry Brigade sends greetings to all old friends. G4CJ and 4FJ are with him.

A.C.2 H. Burton, G2JR, who is stationed in Cheshire would like to hear from his Coventry friends either in or out of the Services. He particularly wishes to contact VE4QS who is a P./O. in the R.A.F. and G2LU who is in the Navy. Letters should be sent *via* his home address, 215, Ansty Road, Coventry.

Congratulations to Ivor Smith, 2BQI, of 29, Wood Lane, Highgate, who has been promoted from Telegraphist R.N.V.(W.)R. to Sub.-Lt. (Special Branch).

P./O. Phil Thorogood, G4KD, who is now on a course at No. 1 Signals School sends greetings to his

friends in Districts 12 and 15. Associated with him are P./O.'s Drage, 2BNI, Dunsford, G6KD, Hendry, BRS3840, Swain, G2HG and Turner, BRS3823.

Edgar Walker, G2LT, 11a, Welwyn Close, Intake, Sheffield, is anxious to contact Lt. Atthill, G8CV. A letter sent to his home at Farnham has been returned marked "Gone Away."

Arthur Broomfield, G6OQ, who is serving in the R.N.V.(W.)R. aboard a very famous P. and O. Liner, has just visited the GI boys. He met G15HU, 6TK and 8PW among others and discovered that an old friend 2FQQ was also in the neighbourhood. Arthur sends greetings to all old friends.

Congratulations to Major W. H. Lloyd, G5TV, who has been promoted to the rank of Lt.-Colonel and decorated with the O.B.E. (Military Division) for his work with the Royal Corps of Signals in France. G5TV in a letter to H.Q. says "I look forward to THE BULLETIN even more than I did in the days of peace. There is that touch of good palship about it which will not die where our hobby is concerned." Col. Lloyd's view is, we know, shared by every member.

Mr. J. Dickson, G2HV, R.N.V.(W.)R., offers to send back issues of THE BULLETIN to any ex-member who through force of circumstances has been obliged to resign. Requests should be forwarded *via* G6CL.

Congratulations to Sq. Ldr. Viscount Carlow, G6XX and to Lady Carlow, on the birth of a second son. Lord Carlow is serving as an Air Attaché to a European Legation.

From a well-known R.A.F. Station in Essex, P./O. Bill Wadsworth, VE5ZM, reports having met G6PA (now a F./Lt.), 6TX, 8TK, 4IO, 2MY, 2BLK and BRS2689. A miniature ham-fest was enjoyed during one afternoon recently. Bill sends greetings to all old friends.

Writing from No. 10 (Signals) R.C., A.C.2 Norman Owen, G4KS, expresses the hope that he will soon meet many fellow amateurs. His address can be obtained from G6CL.

C. D. S. Underwood, G5UD, who was with the R.E. Postal Section in France is now in Shropshire. He sends 73 to all his friends, who will join us in congratulating him on his safe return and on his promotion to Sergeant.

One of our newer service members A.C.1 Fred Boardman, BRS3803, writing from N. Ireland, reports that he has several prominent G hams as companions. Fred was in France with the early C.W.R. members, to whom he sends greetings.

Bill Hamer, G3WT, who is a Telegraphist in the Navy, sends greetings to all old friends in and around Liverpool. He recently met VE3UH, thanks to the old dodge of carrying a copy of the Bull. under his arm.

* * *

Sigm. John Stanffer, No. 1 Coy., 1st Canadian Divisional Signals C.A.S.F. (VE3DF, CJCS-VE9CI), writing from Surrey, sends greetings to all old DX friends. John, who is billeted on a farm (the exact address can be obtained from G6CL) with 20 other Signalmen, would like to get in touch with some member who has for disposal a small 4- or 5-valve superhet chassis and P.M. speaker. He is anxious to fix up some entertainment for the winter. Any offers?

* * *



P/O. Bert Simpson, R.A.F.V.R., G8DI, an early member of the B.E.F. to France, was recently married. Here we present the happy couple on their day of days. We've left the bouquet in for the benefit of the ladies!

* * *

Members of the Thames Valley Amateur Radio Transmitters' Society have learnt with regret that their colleague, Alan Mears, G8SM, has been seriously ill in Belfast. They take this opportunity of sending him special greetings and express the earnest hope that he will soon be in full health. Alan is in the R.C. of Signals.

* * *

L.A.C. Bryan Montague, 2ANR, whose home is at "Onega," Chipstead Valley Road, Chipstead, Surrey, wrote us last month just before leaving for an overseas destination. He asks whether G2ZQ remembers an "illuminating" chat they had together at a N.E. Scottish R.A.F. station recently. Whilst on this station 2ANR met Mr. J. Somers, who requested him to pass the word along that he was the operator of Y16KK some years ago. There was some doubt at the time as to the genuineness of this station.

* * *

Friends of P. D. G. Fraser, G8ST, who until recently was serving in the R.C. of Signals, will be interested to hear that he has been appointed to the Indian Army. Letters can be sent *via* his home, Meadow Cottage, Hemingford Grey, Hunts.

The many friends of Mr. E. J. Williams, B.Sc., G2XC, will be interested to hear that he is now serving as an A.C.2 in the R.A.F. G2XC has been the Society's Propagation Manager for some while and has also prepared "Cosmic Notes" each month. He is a past holder of the Powditch 28 Mc. Trophy and a prominent contributor to this Journal.

Best of luck, Ted, and here's to early recognition of your talents.

* * *

One of our regular correspondents at No.3 R.A.F. Signals School, Cpl. A. M. Boyce, 2CMR, reports that recent trainees have included 2FRT, 2FXS, 2FZU, 2FTN G3RR, 2FZ, 4GG, GW2XZ and GM6DU, together with several BRS. 2CMR extends his congrats to G8DI on his advancement to commissioned rank.

Thanks to some excellent spade work on the part of Cpl. Boyce and his friend Cpl. Edwards, several new Society members have recently been enrolled.

* * *

P/O Harry Jefferies, GM8HJ, after completing a Course is now attached to a station in the West of England. He wishes to be remembered to old friends and to those amateurs who recently shared life in the mess with him at No. 1 Signals School.

* * *

L.A.C. J. Dowding, G8DO of Guernsey, would be glad to hear from any of his old Channel Island friends. Letters can be sent *via* his new home address 29 Vyner Street, Ripon, Yorks.

* * *

Writing from "Somewhere at Sea" under date of October 1, F./Lt. J. V. Newson, G3GY, reported the presence of several hams aboard ship. No details of their destination are yet available.

* * *

Michael Pittam, BRS2977, who is serving as an Ord. Seaman on H.M.S. *Edinburgh Castle*, reports having met G8KU and ZS5B in the course of his duties. Apparently the BULL. is very welcome, but they complain that it arrives one month late!

* * *

News has just been received that Lt. A. N. Lister, G5LG, has been a prisoner of war in Germany since May. No details are yet available.

Silent Key

**JESSE VYSE (G4IR),
WIRELESS OFFICER M.N.**

It is with deep regret that we record the death, at the early age of 18, of Jesse Vyse, G4IR, whose home was at Hull. Although a non-member of the Society, he was a keen amateur and liked by all who came in contact with him.

Jesse Vyse succumbed to the effects of exposure after being adrift in a lifeboat for 13 days, when the ship on which he was serving as Wireless Officer was blown up.

On behalf of fellow amateurs we extend our deep sympathy to his parents, sister, and friends.

J. M. A.

G3BG, 3PJ and 8RI, who are civilian operators at a P.O. radio station in N.W. England, send greetings to the old gang who worked at the H. F. end of 7 Mc. We understand they have the ideal ham shack at present!

One of our new members, P. Pearce, G4AA, writing from a well known R.A.F. station in Yorkshire, tells us that he is now a sergeant observer engaged in "giving Jerry something of what he is giving London." Before his station was closed down Sergeant Pearce operated with very low power (usually less than 1 watt input) from Croydon.

Friends of 2/Lt. Stanley Isaacs, G6ZY, will be interested to hear that he is now in Gibraltar. He had a pleasant surprise on landing when he discovered his O/C was Major Solly, ZB2B.

Capt. R. Postill, G8NO, continues to instruct potential officers for the R.C. of Signals. We understand a well known District 12 DX man under instruction was considerably shaken some time ago when "Test DX" rattled along a land line circuit operated by G8NO!



BELFAST'S HOSPITALITY

How well the amateurs of Northern Ireland are taking their share in extending Ham Hospitality is illustrated in this photograph taken recently at the Y.M.C.A. Radio Club in Belfast

Back Row :—2HCC, G18PA, 2BYC, G15HU, E18F, G18GK, BR52754, G13KN
Centre Row :—G8PR, 2AMW, Mr. J. H. Ireland (Secretary, Y.M.C.A.), G2YN, 2FQQ.

Front Row :—G15UW, 5ZY, 6TK, 2CHJ

ON ACTIVE SERVICE FOURTEENTH LIST

WE publish below our fourteenth list of radio amateurs on active service. Additional details and corrections should be advised to Headquarters as early as possible. The present list contains information received up to November 2, 1940.

Rank and Name	Regiment or or Branch	Pre-war Call or B.R.S.
P./O. J. M. S. Adams ..	R.A.F. ..	3835
L.A.C. G. V. Catt ..	" ..	G4FV
A.C.2 E. W. A. Colls ..	" ..	3741
L.A.C. G. E. Cooper ..	" ..	G3PP
A.C.2 R. S. Cross ..	" ..	G2FZ
L.A.C. J. F. Davis ..	" ..	G3CI
L.A.C. J. Dowding ..	" ..	G8DO
Sig. R. S. Evans ..	R.C. of S. ..	3873
W./C. F. G. H. Ewens ..	R.A.F. ..	3869
L.A.C. J. A. Gough ..	" ..	3872
C.P.O. Tel. T. W. Home-wood	R.N. ..	3623
Sgt. R. Lansley ..	A.M.P.C. ..	G4KV
L.A.C. P. G. Medcalf ..	R.A.F. ..	2FXU
F./Sgt. A. P. Morgans ..	" ..	G8DV

Rank and Name	Regiment or Branch	Pre-war Call or B.R.S.
A.C.2 J. J. B. Paine ..	R.A.F. ..	3867
A.C.2 E. Powell ..	" ..	GW3QB
F./Sgt. A. Redman ..	" ..	3863
Lt. E. J. Ritchie, B.Sc. (Eng.)	R.E. ..	GM3KU
Major H. C. B. Rogers, O.B.E.	R.C. of S. ..	3865
A.C.2 R. J. Rider ..	R.A.F. ..	G8IX
A.C.2 B. K. Rowell ..	" ..	G5RL
A.C.2 C. B. S. Seaman ..	" ..	2603
A.C.2 F. Smith ..	" ..	2DDX
A.C.2 H. D. H. Smith ..	" ..	G6YN
A.C.2 G. R. Strobe ..	" ..	3861
A.C.2 A. E. Sutton ..	" ..	G3BN
L.A.C. L. M. Trimmer ..	" ..	2FDB
A.C.2 R. A. Watson ..	" ..	3871
L./Cpl. R. Wilkins ..	R.C. of S. ..	2ALM
A.C.2 E. J. Williams, B.Sc.	R.A.F. ..	G2XC
A.C.2 F. Wiseman ..	" ..	G6TM
A.C.2 B. J. Worboys ..	" ..	3545
P./O. R. C. M. Young ..	" ..	3862

Corrections.—L.A.C. W. H. Abraham (GW3AX) recorded as GW3AJ in List 13.
A.C.2 (now Sgt.) S. R. Cooke (2CTC) recorded as non-member in List 3.

WINGS OVER THE TUMULI

In fairness to our contributor we relieve him from the responsibility for coining the above title.

We hope that one of our members has now discovered tumuli are not edible!

FOR the second time in two months some three score service members and their friends, who are living *pro tem* in the "Land of the Tumuli" gathered together on September 29th, for yet another R.A.F. Conventionette, the actual venue being the N.A.A.F.I. Canteen attached to No. 2 Wing of the No. 2 E. & W. School.

Among those present was Franta Horkey, OK2HY who is under training at the School.

The proceedings were opened by F/Lt. C. Plant, G8DU, who expressed his regret that Mr. J. Clarricoats (Secretary-Editor, R.S.G.B.) had been prevented from attending. In his absence he called upon P/O Hubbard, G5OX ("Oxo" to all his friends), to say a few words concerning R.S.G.B. activities.

Mr. Hubbard in associating himself with the Chairman in his expression of regret that G6CL was not present, put the meeting at ease by saying that with no "little black book" to provide moral support, he proposed confining his remarks in the main to the splendid work which is being rendered by amateurs who are serving in the R.A.F. It was, he believed, correct to say that nearly 60 per cent. of the R.S.G.B. members serving in H.M. Forces were wearing R.A.F. uniform. From every quarter he had learnt that the hams in the R.A.F. were living up to the high traditions of the amateur movement. The benefits which should accrue to the Society as a result of war experience should prove of an estimable value in the days to come. "Ham spirit," that indefinable spirit which pervades officers' messes, barrack-rooms and dug-outs, was proving to be of even greater significance than in pre-war days. He was glad to remind the company, as G6CL had done at the previous meeting, of the Toc H motto "Abandon rank all ye who enter here." How well everyone responded to that appeal was demonstrated throughout the meeting, when all ranks divided into groups to yarn and exchange experiences.

P/O Hubbard concluded his much appreciated talk by expressing his thanks to all who had made possible the meeting, mentioning in particular F./Lt. Plant, Cpl. Bridges and his Committee.

Our friend from Czechoslovakia was then called upon to address the meeting. In extremely good English he spoke of the activities of the OK amateurs in peace time, mentioning especially the good work which they had done in connection with A.R.P. communications. Prior to the Nazi occupation he stated that newly licensed OK amateurs were only permitted to use an input of 5 watts.

Those present loudly applauded OK2HY when he sat down and the cheers were repeated when the Chairman stated that he had only been learning to speak English for two months. Many of us must have wondered what *our* knowledge of the Czech language would have been after a similar period.

Next followed a talk delivered by Cpl. Wright on the subject of Superhet Design. The speaker made it clear that although not an amateur in the accepted sense of the word, his work followed along the lines of most experimenters, and for that reason he proposed considering design problems as they apply

to short wave and ultra-short wave reception. After a lucid explanation of frequency changer methods from the early days of superhet development, Cpl. Wright dealt in detail with the whys and wherefores of electronic mixing. The effect of using different intermediate frequencies was mentioned and advice given on the problem of overcoming second channel interference.

An explanation was given of the working of the double superhet, a receiver in which the speaker stated he was especially interested. It will be remembered that this type of receiver employs a crystal in the second R. F. Oscillator stage.

The talk was concluded with references to English and American valves, the speaker giving reasons why in his view, present-day English valves were superior to their American counterparts.

The meeting registered its appreciations to Cpl. Wright in no uncertain fashion, after which came a call to tea.

Following a very enjoyable meal the company settled down to listen to a well staged debate on the age-old subject "QRO v. QRP." Speakers were allotted three minutes to express their views—a wise precaution!

Cpl. Turner, G3VI, Cpl. Heathcote, G3JR, and F./Lt. Bamford, G5JB, put forward the case for low power, only to be set upon in earnest by the high power fraternity led by F./Lt. Plant, G8DU, Cpl. Farmer, G3XP and a second operator of GW3GO. So many and varied were the arguments put up by both sides that a draw had to be declared after G5OX had summed up.

The latter part of the proceedings, suggested by G5JB, took the form of short informal talks given by old timers who were asked to bring back to their minds some of their earliest radio experiences. The originator of the idea started the ball rolling by relating some details of component costs in the years around 1925-6. A vivid description was also given of an 11-valve superhet which he used at that time. Those were the days, said the speaker, of Two Emma Tock, Writtle, when hams were as rare as are currants in war-time buns!

F/O J. N. Walker, G5JU, who, in company with F/O Max Buckwell, G5UK and three others, had flown over from a near-by station, recalled even earlier experiences, mentioning his reception of many world-famous spark stations during the early '20's." He mentioned that his first contact was not with a Britisher, but with the famous station F8AB operated by Leon Dely in Nice. He referred also to early experiments in re-filamenting valves, and mentioned that one of his first aerials contained over 1,000 feet of wire!

Cpl. Farmer who spoke next said that he began experimenting as a pirate when still at school, his confederate being located across the town. A converted medical coil and crystal receiver provided the be-all and come-all of their ambitions. He recalled early attempts to make magnetic and electrolytic detectors and referred to the reception of the Hague telephony transmissions during 1923 or thereabouts.

(Continued on p. 164).

73.

G2CP (H.M.S. Selkirk, c/o G.P.O., London), to G2TK, 3KS, 4DY, 5GI, 5MV, 6CP, 6OO, 6SO, 6TG, 6UJ, 8BB, 8KU and all ex-members of S.S.W. Society.

G2PB (R.A.F.), to G2HW, 3AT, 3TU, 4CJ, 4GM, 4KT, 6BH, 8FI and members of Blackburn Group.

G2UX (c/o 204 Bellingdon Road, Chesham, Bucks), to G2GZ, 2JB, 2JK, 2UT, 3QF, 4DC, 4PO, 5JA, 5PY, 6CY, 6OW, 2AMW, and all S.L.D.R.T.S. members.

G3BU (15 Abbeymead Road, Abbey Lane, Leicester), to G3AY, 3HL, 3TP, 4BJ, 5GN, 5MY, 6IM, 8CZ, 8HR, 8QZ, 2HBG, 2CFC.

G3GW (R.A.F.; Home address, "St. Austell," Barton's Hill, Minster-on-Sea, Sheerness, Kent), to G3OA, 3OJ, 3WP, 4BY, 4FI, 4FN, 4HG, 5MM, 6AB, BRS1295.

G3KB (R.A.F.), to G2XY, 3XN, 3YK, 4FO, 5LW, 5VC, 6JB, 8BK, 8FP, 8UO, 8WS and BRS3797.

G3NB (R.A.O.C.), to G3KX, 3XR, 4AR, 4HC, 5BW, 5TN, 6LQ.

G3OJ (86 Grange Road, Felixstowe, Suffolk), to G2YS, 3GH, 3GW, 3TL, 3WP, 4RW, 5MM, 5UM, 5VS, 6AB, 8TL and 2HLP.

G3YY (1A Dover Road, Brighton, 6), to G2AO, 2RU, 4JH, 5LU, 6BW, 6WO, 8CP, 8OQ, 8OS, ZL4DQ, W5KC, W8JFC and all old 56 Mc. friends.

GM3ZH (The Elms, Galashiels), to G2MI, G13UP, G3KB, 3QS, GM3UA, G3YJ, 3YK, 8FP, EI7M.

G4AH (R.C. of S.), to G3LD, 4LY, 5QZ, 6FP, 2AMY, 2BSR, 2CIB, 2DRT.

G4HV (16 Keswick Gardens, Ruislip), to G2JI, 3FS, GM3HY, 3LO, G3OZ, GW3XW, GM4BK, G4CP, 4HT, 4KD, GW8SO, G8TK.

G4JW (79 Glebe Road, Sheffield 10), to G2LT, 2MF, 3VY, 4KB, 4KW, 6TD, 8IO, GM3KC, 3LO, GW3XW, G13ZX, 2HMN.

G5FN (c/o W.P.S., Imperial Buildings, Mount-stuart Square, Cardiff, phone: 7924, ext. 20), to G2CM, 2IG, 2MI, 2VA, 4HG, 5MM, 5XB, 6NU, 6RQ, 6UT, 2AFT, 2BOL and the M.R.S.I. (Medway Gang).

G5PY (18 Parkthorne Road, London, S.W.12), to G2JB, 2JK, 2UJ, 2UX, 3CI, 3CU, 3GS, 3ST, 4DC, 5CI, 6HM, VK5TK and all Ham friends.

G6QZ (3 Barnham Broom Road, Wymondham, Norfolk), to G2UJ, 2UT, 2XS, 2YL, 5IX, 5QO, 5UD, 5UF, 6CW, 6DH, 8FL, 8IY.

G6SO (10 Sydney Street, Scarborough), to G2JK, 2UF, GW3KY, G4JD, 5CJ, 5GI, GM5KQ, G5SO, 6BC, 6UJ, 8ND, 8PO.

G6VD (9 Cecilia Road, Leicester), to G2IX, 2RI, 2WS, 2XD, 3BU, 3HL, 4BJ, 5GN, 5UQ, 6IM, 8CZ and GW8WJ.

G6ZY (Gibraltar), to G2QO, 2ZQ, 3BQ, 6WN, 6XX, 6ZO, 8CK, 8DR, 8FF, 8IH, 8IT and EI5M.

G8BQ (R.A.F.), to ex G2LR, 3AN, 4KZ, 5BD, ex 6AC, 6LI, 6TV, 8AP, 8GI, 8PR and all the Thursday nighters at No. 11.

G8CP (Newhaven Rectory, Sussex), to G2NY, GW3AX, G3KI, 4NX, 5AQ, 5CP, 6BW, 6RM, 8FI, CW8HI, 8IT, 8ND.

G8HA (R.A.F.), to G2GK, 2PL, 3OR, 4BR, 5WP, 6WY, 6ZO, 8CK, 8FF, 8LT, GM6JD, 6MD.

G8NO (R.C. of S.), to G2UJ, 5OQ and 6OB and all other Tonbridge members.

G8PP (R. C. of S.), to G2XG, 3GM, 5BQ, 6TU, 8LX, 8MB, 8PC, 8PL, 8TV, 2DVA, GM3LG, W9TJ.

G8UL (48 Sunny Bank, Hull), to G2FX, 2RX, 2IZ, 2KO, 2VO, 5CJ, 5QG, 5JO, 6SO, 6GO, 6QF, 6VQ.

2DVA ("Restormel," Old Higher Road, Halebank, Lancs), to G4OO, 5KA, 8PL, 8PP, 8TV, 2DKD, VE3PT.

"HAM-RADIO" CROSSWORD No. 5

SOLUTION

1	C	5	R	A	M	I	C	7	F	A	9	T	O	R
	H		A	S		D			R	O		T	A	R
2	A	3	B	Y	S	11	S	13	I	N	15	A		6
													P	I
3	S	E	M	A	T	O	L	O	G	Y				E
4	S	I	A	M		T		L	I		17	T	20	A
22	I	R	R		23	A	24	F	I	L	E	25	U	T
26	S	A	T	27	L	L	I	T	E	28	A	R		
				29	C	L	O	S	E	30	I	R	A	N
32	A	33	I	L	Y		T		34	U	N	C	L	E
35	I	E		I		36	S	37	F	S				P
38	P	R	O	P	E	L		39	U	R	U	G	U	A
40	O	I	L	S		41	A	B	S	O	R	B		42
43	A	D	E		44	N	U	E	C	E	S		45	T
46	E	L			47	E	G	G		K		48	K	S

THE MONTH "OFF" THE AIR—October, 1940

By ARTHUR O. MILNE (G2MI)*

Thanks

VERY many thanks to all who have so splendidly rallied to the call for reports. The response has been most gratifying, so please keep it up and help to make this feature more interesting to your pals.

Notes and News

BRS3821 says that KC4USA still comes in well in the early mornings on 14 Mc. 'phone and is usually the best signal on the band with KF6SJJ a good second. Other stations heard include K6LUJ, 6MYD, 6MYZ, 6FRZ, 6PAZ, 6SKZ, 6SBQ, 6SRZ, ZP3AP, KAIDM, W6LS and 6NYD, all on 'phone. K7BUB has been heard a great deal but his location is not known. YT7TT is also very active.

G2RC and several others have reported "ZB2FQ" who says he is in Gibraltar! From observations made during a contact with D3DSR it would seem likely that he is in Spain. Other DX heard includes NY1AE (14360), CE3AJ (143326) and CX1BO. KC4USC, K4EIL, 4DIF and 4GTH have been heard on 28 Mc. at S9, for full particulars see the 28 Mc. notes. 3.5 Mc. has also produced a number of good 'phones whilst CM7AF puts in a thumping signal on 7,125 kc.

BRS991 and G5RI in a joint report covering September mention ZB2OD and ZB2FQ, both purporting to be in Gib. Other "bad hats" include ZC6Q, TA1UR, SV1XA, LZ3WW, HB3BZ, HB3BB and SM7NR—all but ZC6Q were heard on 7 Mc.

New Germans recently copied are D3DMC, 4ACS, 4AMF, 4CSA, 4DVF, D4LKM, 4WHW, 4XDV and 4XJF.

G8ML comments on EPIAC working D4LEU claiming Tehran as his QRA. I2SA was another queer one calling CQ.

A very encouraging letter comes from G3QD, who says conditions were poor during the first part of October, brightening up around the 19th of the month. An early morning watch on the 20th was almost like old times. 7 Mc. produced W1, 2, 3, 4, 8 and 9, U, TF5C, SV1XA, YU7AL and HA, together with the usual flood of Germans. 28 Mc. has not been brilliant so far this year; it is surprising what a difference just one year can make in the effect of the solar cycle on this band. During October two large sunspots were observed which probably accounts for the patchy conditions during the month. Even the 15 Mc. broadcast stations have been unusually weak and fluttery. 3QD concludes his letter in these words: "I'll send an envelope, just in case you may have just one little QSL card for me. Believe me, it would be a real tonic! Often I go into my shack, look at the cards on the wall and ponder the days of yore."

G5PY, now in Devonshire, remarks on the large number of Germans and Russians on 7 Mc. Estonians are also numerous and still use their old calls. EA1AL, F3NW, F8IO, CT1JU and CT1DF, as well as other calls detailed elsewhere, have been logged. On the 7th he heard W4RHH

at S5 on 7,125 kc. at 16.44 B.S.T. A card from W8UHF reveals that he had logged the American's 7 Mc. harmonic when he was using 30 watts to a 6L6 on 3.5 Mc.!

BRS3789 is now in Sheffield and hopes to be active with the receiver again soon. At the moment, he is busy building a pre-amplifier.

G8PP, writing from East Anglia, mentions a recent visit to BRS3610. Here they spent an interesting time comparing signals from a HRO and a NC44, the latter being fitted with a home-made preselector. They were surprised to find that the HRO's performance was definitely inferior. The "catch" included K7GOR and W7HBK on the NC44, which were inaudible on the HRO. Other stations heard were KA1AA, KA1HR, LZ1US and W6NPU (Utah).



Ted Bracher, ZS2P,
a recent visitor to
Belfast

GI6TK sends in a very interesting log with the following highlights, K4GPU, 4GQO, 5AG, W5ICH, 7GPR, 5IJW, YU7XI, CM2AZ, W6RIF (Utah), 5FIZ, 6QAR, K5AU, NY1AE, KB6RVN and HH2MC.

G8IO reports a pirate broadcasting station on 14 Mc. We can't have that! His loudest signal was PY1CQ.

BRS3607 is another who has a good bag of K4's. The best W was 5BEK. BRS3766, who has heard 131 countries, also notes a number of American calls.

From GI6TK we learn that Lt. L. Scholefield, G5SO has had all the QSL cards which qualified him for the DX Century Club stolen from his car whilst in Belfast. It is hoped that DX stations who have worked G5SO will furnish further evidence of the contact.

Luftwaffe and All That

Congratulations to G2YL on her lucky escape. We are glad to know that "Redholm" and its

* 1, Kent Drive, Harrogate.

occupants are unharmed. G2MI's Hayes QRA was missed by about 30 yards on both sides recently. Yet, although in one case there is a crater the full width of the road, the total damage to "Twemigh" was one cracked tile!

G8TL, minus his roof and most of his windows, writes a cheery letter from his shelter. His house still stands but has given him wide scope to show his ability as carpenter, glazier and slater! "The Cabin," he writes, "was nearly rendered 'portable-mobile' recently but still refuses to lie down."

G2CD has temporarily removed to make room for a D.A. bomb. G2XP is quite fit and well, having erected a cosy shelter in his dining-room! So far he has successfully dodged the "old iron showers!" G6OF reports all correct and G3MD has also come off lightly. G6HU is another East Londoner who has missed it so far and hopes shortly to be called into the comparative safety of the Army! 2CKJ is still in his old home town but visits London fairly regularly.

2BRH of Ilford, affectionately known as "Junks" still carries on from an undamaged shop and has spread himself on gadgets for his super shelter! The monthly meetings in Ilford have been temporarily suspended, as no one has a shelter large enough to hold all the gang!

G8TL recently had a letter from old John Preston, BRS1295, of Weekly Report fame. He is quite fit and most appropriately is in charge of an observer post. All his sons are in the fighting services and his daughter is an Air Raid Warden!

As we feel that news of how the Hams are faring under the air war will be of general interest, we shall be glad to hear from anyone in the "firing line." News must, of course, be of a purely personal character and care taken not to give information which might be of use to the enemy.

American Commentary

A welcome letter from Ralph Summers, W8OQF, mentions that he has just been promoted to the post of manager of his firm's new factory. This has necessitated a change of address to Box 204, Portland, Mich. He sends 73 to his many friends in this country and asks G3HS, 2FCJ, 2FTN and his other correspondents to forgive delay in answering their letters. WIWV, who also sends best wishes to all British amateurs, has just qualified for B.E.R.T.A. with the final card to hand from ZL4AO.

All letters from America speak of 100 per cent. support for the Allied cause and tell of the terrific speed-up in America's productive effort. As one U.S. amateur recently wrote: "We're quite prepared to forgo the honour and glory of direct intervention because we can do far more real good as we are!"

Gibraltar

Sgt. Waddington, ZB2B, finds life rather dull and would very much like to hear from some of his pals in Britain. "There's nothing like a letter about Ham Radio," he writes. How about it, chaps? Letters may be forwarded to him c/o. G2MI, 1 Kent Drive, Harrogate. He sends 73 to G4CL, 2SG, 2UT, W2IXY, W2IKV and W2CYU.

Keep up the good work, chaps, more and more reports please. Cheerio till next month.

All part of the M.A.R.S. Service

G2MI would like to thank the many Birmingham who so kindly 'phoned, visited and wrote to G5XB, as a result of the note in last month's issue. The two stations are now QSO. "Thankin' yew!"

The 28 Mc. Band

By NELLY CORRY (G2YL)

FOR the first eleven days of October it looked as if the DX heard in September had only been a "flash in the pan," but conditions improved considerably later on, and W's were logged daily (except on October 22), to the end of the month. The general impression was that signal strengths were lower, QSB more pronounced, and the band open for shorter periods, than in October, 1939.

In this connection it is interesting to read in a National Bureau of Standards article in QST for October, the statement that one of the direct results of skip distance gradually lengthening with the waning sunspot cycle, will be the absence of regular long-distance transmission on 28 Mc. for five or six years after this winter.

During October, signals from Oceania, Asia and Africa were inaudible and only a few European commercial harmonics were reported, viz., EAK, FZM, IRX and three or four Russians.

The only South American amateur heard was PY7VB, logged by BRS3003 at 15.28 G.M.T. on October 12; incidentally, he is one of that now almost extinct species, the 28 Mc. "c.w. ham." LSA and LSA2 on 27.5 and 31.5 Mc. were heard by G4MR and BRS3003 on 21 days during the period October 1-26, so probably the lack of amateur signals heard from this continent is mainly due to reduced activity. Most of the South American hams' pre-war 28 Mc. QSO's were with Europe and North America, and there is very little to be gained by any of them calling CQ on this band under present circumstances. Porto Rico stations were heard by G4MR, BRS3003 and 3821 on October 4, 6, 10, 20 and 24, and included K4ENT, 4EZR, 4FRN and 4GTH.

West Coast W's were not up to the standard of previous autumns, but a few W6's were logged by G4MR, 2DYN, BRS3003 and 3821 on nine days, between October 12 and 25. East Coast and Central Districts stations were more prolific and were heard at times varying from 13.00-22.00 G.M.T., though they were usually at their best in the early evening. G4MR logged U.S.A. police stations above 30 Mc. on October 14, 15 and 16, and comments on the large number of W5 amateurs audible.

Many thanks to G4MR, 8VG, 2DYN, BRS3003, 3425 and 3821 for their very useful reports.

The Ultra-Highs

By CONSTANCE HALL (G8LY)

AFTER their summer break the editorial staff of *Radio* have come back to the fray with a fine October issue full of interest for the U.H.F. enthusiast. Our old friend E. H. Conklin, W9BNX (the U.H.F. Editor) spreads himself over seven pages in which he summarises the achievements of the U.H.F. gang during the past few months.

Two interesting "Honour Rolls" are published—the first shows that W5AJG has worked all 9 U.S. Districts, and no less than 34 States on 56 Mc. He is followed by W9ZJB with 9 and 27 whilst W9USI is a good third with 9 and 23. In the second Honour Roll we find it recorded that W6QZA-OIN retain their 112 Mc. record of 215 miles from elevated positions with W6BCX-OIN holding second place (201 miles). The best from home stations was a 90 miles contact between W1HBD-W1XW made way back in 1935. The second best distance (74 miles) was covered by WISS and W1BBM.

Conklin confirms that July 23 was the big day of the year. At least 75 contacts were established on that occasion by several of the W5's whilst W6QLZ had an amazing day during which he worked or heard all Districts bar W7. He was using a concentric line receiver. It is of interest to record that this station logged commercials up to 45 Mc on 14 mornings before 9 a.m. local time, without hearing a single amateur signal on 28 or 56 Mc.

Conklin has inaugurated a Question and Answers Section which should provide an added interest to those who follow his commentaries. Space prevents us from mentioning the matters dealt with in the issue under review so our advice is, become a subscriber.

"The Design of Single-ended, U.H.F. Amplifiers" is the title of the leading article in October *Radio*. This includes a description of a 112 Mc F. M. transmitter using the amplifier circuit described. An 807 is used in the final stage. A description of a 112 Mc Converter with a 14 Mc to 112 Mc preselector forms the basis of another U.H.F. article in the same issue.

Apparently some confusion exists between *Radio* and *QST* in regard to U.H.F. records on 112 Mc., for in the October issue of the latter journal we read that W6BJI/6 and W6KIN/6 contacted one another over a distance of 255 miles on July 4, 1940 beating the W6QZA-OIN contact (given as the record by *Radio*) by 40 miles. *QST* also records that W1EYM and W6DNS retain their 56 Mc record of 2,500 miles established on July 22, 1938.

The July winner of the A.R.R.L. U.H.F. Marathon was W6QLZ with a score of 730 points. During the same month W1KLJ made 214 contacts on 56 Mc, 7 on 112 Mc and 5 on 224 Mc.

We must apologise for the omission of home news, but with the exception of further observations on Moon Theory forwarded by BRS3766, there is little to report.

The writer believes that with space restricted it is better to record *happenings* rather than *theories*. Members interested in theoretical aspects of U.H.F. may perhaps like to circulate their views through one of the Experimental Section letter budgets.

W1HDQ, 9BNX, G3YY, 8OS, 2DXS, BRS1151, 2817 and 3766 are thanked for their letters and encouraging remarks. All news for this column must in future reach the compiler by the 25th of the month.

Kilocycles-Metres Conversion Booklets

Copies of this very useful 64-page publication, in vest pocket booklet format, are available from Headquarters, price 1s. 6d. each, post free.

"HAM-RADIO" CROSSWORD No. 6

Prepared by ALAN J. BAYLISS (G8PD)

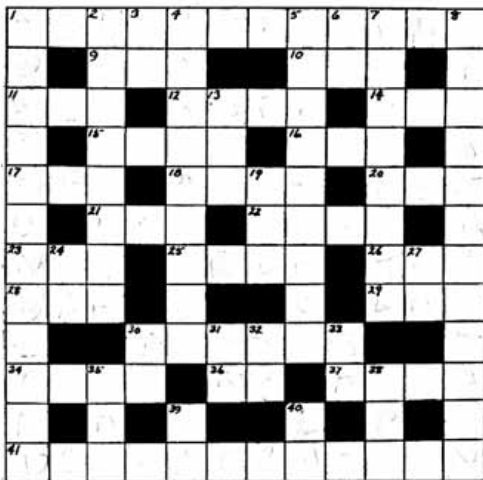

CLUES

ACROSS

- 1. Most power amplifiers need this.
- 9. An American organisation.
- 10. Male human being.
- 11. In many cases amateur activities are curtailed when one is this.
- 12. An enemy of all electrical apparatus.
- 14. Irate B.C.Ls. often threaten to do this to amateurs.
- 15. An Eastern Ruler.
- 16. A bird found in VK.
- 17. Old Vienna (Call Sign).
- 18. Found in accumulators.
- 20. Allow.
- 21. Non-Members of the R.S.G.B. may fall into one of these.
- 22. A mythical story.
- 23. In Germany this is new.
- 25. Found in transformers.
- 26. A hill.
- 28. A man's name (also a German commercial call sign).
- 29. A British television system.
- 30. F.W. rectifiers have two of these.
- 34. With 1,000v. one of these makes a kilowatt.
- 36. Broadcast (abbr.).

- 37. A steerable aerial system.
- 41. Negative feedback.

DOWN

- 1. A land connected with Marconi's name.
- 2. To do this to them usually lengthens valve life.
- 3. Two letters well known to R.S.G.B. members.
- 4. This leaves the aerial.
- 5. A complex resistance.
- 6. South Africa (abbr.).
- 7. To render non-conducting.
- 8. She still rules the waves.
- 13. This can often be drawn from a tank coil.
- 19. A prefix from the Greek meaning equal.
- 24. Spain in the amateur world.
- 27. Old man.
- 30. Like.
- 31. Old boy.
- 32. Direct current.
- 33. The prefix for Sweden.
- 35. Most licensed amateurs have written to him at least once.
- 38. A prefix from the Latin meaning one.
- 39. French India (call prefix).
- 40. A musical note or a country.

SOLUTION NEXT MONTH

Welding Metal to Glass.

An interesting paper entitled "Welding Metal to Glass" has just been issued by Andrew Reid, 14 John Adam Street, London, W.C.2, on behalf of Pilkington Brothers. Members interested in this subject may obtain a copy on application to the above address.

A new method of sealing glass to metal is reported from the laboratories of the Radio Corporation of America. A brief survey of the method is recorded in the current issue of *Electronics and Television and Short Wave World*.

BRITISH ISLES NOTES AND NEWS

District Notes

Due to prevailing circumstances we would urge all D.R.'s and Scribes to post their notes in time to reach Headquarters by not later than November 28.

DISTRICT 1 (North Western)

Blackburn.—The T.R. wishes to notify all local members that he has returned to his home address after a short absence. He was disappointed at being unable to meet 4CJ and 2AKK when they were home on leave. 2FLW, G4FD and 2TM are frequent visitors to 4KT, whilst 2HW and 8JA attend when business permits. G2TM and 2FLW are building superhets and wondering what bands will be allotted after the war. (Aren't we all?—ED.)

The T.R. is pleased to note that other groups in the District are still active and to learn that 8GG is safe and sound. He is looking forward to working the latter on 1.7 Mc. again, and to the usual Blackburn and Bury "ragchews." Greetings are extended to ZD2H (G2QN) on behalf of the Blackburn members. 2FUC has been home on leave.

Cumberland.—G4NS, 6ZT, 8RZ, 2AUM and 2HHV enjoyed a pleasant evening at G6WR on October 10, and some amusement was caused by a number of Morse records belonging to 2AUM. The members were obviously "rusty," and most preferred the slower speed. 6ZT came over from Whitehaven, and it is hoped that he will be a frequent visitor.

G6SZ returned to Whitehaven during the month on a short visit, but was only able to meet 6WR and 2AUM owing to his limited stay, although the T.R. had a lengthy telephone conversation with him. 4PU, of Cleaton, is now in Egypt; 2AYH, of Carlisle, is very busy and reports that 3HS is stationed at Wilmslow. Nothing has been heard of 2DWG. What about dropping the T.R. a line? 3SY of Workington is still busy in the radio trade.

Best wishes are sent to G3BW, 3HS, 4PU and 6VZ.

G6CX.

DISTRICT 2 (North Eastern)

We are pleased to announce that Mr. Edgar Walker, G2LT, 11a Welwyn Close, Intake, Sheffield, has offered to prepare notes covering the Sheffield Area. Members in that town whether in or out of H.M. Forces are cordially invited to send news to him direct.

His first report follows:—

G2MF, 3FN, 3UX, 4AI and 6PJ are on active service, 2JI, 4JW, 5TO and 8RX are Special Constables, 2LT is a Voluntary A. R. Warden, 4HT is busy on his receiver and reports good signals on 28 Mc, 3MY and 3RZ are studying medicine at the University, 8IO, with a new DB20 for his RME69,

reports listening on all bands, 3RP is now employed in Manchester.

Welcomed from Bournemouth is Douglas Kay, BRS3789 who is assisting 8IO in the construction of home-made relays.

Keighley.—Old timers will be pleased to have news of G5ZI, who operated from Thornbury in the early '30's. He is now sergeant i/c of an R.A.F. station "somewhere in England." 4MC, who is an instrument mechanic, R.A.F., has left the "drome near home" and is on a conversion course at a station in the West Country. 2VO is studying at the Royal Dental Hospital and has little time for radio. We are pleased to welcome G3KB (R.A.F.) to membership. Further news from him would be appreciated, as also would news from 6MC, 6HF and members of the Bradford group. 8UO, in spite of being on war work for 12 hours a day, is endeavouring to get meagre information for these notes. Keep in touch with ham friends *via* mail and snatch a few moments to listen on the ham bands, is sound advice.

In regard to the Special Note to Service Members published in the last issue, letters have been received from GW5BI and G5GJ. If amateurs located in military and R.A.F. establishments in Yorkshire will send their QRA, to G8UO, 13 Chandos Street, Keighley, he will endeavour to put them in touch with one another. Remember there may be fellow amateurs located in *your* camp who would like to have a ragchew. The names and addresses of members still in civilian life who are located near military or R.A.F. establishments in the county and who would care to entertain fellow amateurs for a few hours during off duty time, would also be welcome.

G8UO.

DISTRICT 4 (East Midlands)

Mansfield.—The October meeting saw most of the usual faces and by an interchange of correspondence from members playing in the *away* teams a survey of the news in general was passed around. The Acting T.R. (G8MR) would like it made clear that any amateur, member or not, is welcome to these monthly meetings. 2DTQ is on a technical instruction course and hopes the knowledge will be useful when the QRM dies down, 8NS is proud of his 80 hours flying but got a bit caustic about the appearance of 8HX's station from the air. The last two members to join the Forces promised to keep in touch but have changed QRA without notifying 8MR. What about it, 8SA and 2APT?

Nottingham.—The T.R. was very pleased to receive a visit from P./O. Simpson, G8DI, of Liverpool, who is now stationed near Nottingham. Another visitor was G4LY (R.A.F.), who was able to give some news of quite a number who are at one of the Signals Schools. A hearty welcome is extended to 2DTV, BRS3830 and BRS3837 who are new members. It having been suggested that monthly meetings should be held at local QRA's, a rota is being prepared. Particulars are obtainable from G8DZ at 17 Newstead Avenue, Mapperley, Nottingham.

Leicester.—The membership here is getting very thin in terms of those left at home, nearly everybody is either away altogether or otherwise for fairly long periods on one job or another. The rest put all their spare time into National Service. Meetings are now held each alternate Sunday morning at G6VD, and a line now and again from the lads in Khaki and Blue would be appreciated. Our latest addition to the R.A.F. is P./O. R. G. Frisby, 2CFC, who took his appointment during October.

Nothing has been heard from Derby or Northampton for some little time and the D.R. makes yet another appeal for a public spirited member to keep him posted. G2RI.

DISTRICT 6 (South Western)

No reports have been received this month from any part of the District. This is a great pity as the lads who are away like to hear about what is going on at home. It is hoped, therefore, that all who possibly can will send a line to the D.R. each month.

The only thing to report regarding Torquay is that an interesting letter has been received from BRS 3171, now in the R.A.F. Thank you very much O.M. G5SY.

DISTRICT 7 (Southern)

A marked improvement in the notes this month due to the efforts of G2KU, 2HNO, and BRS3005. Keep it up, chaps! Now then, Kingston, Oxford, Reading and Southampton, WHAT ABOUT IT?

Bournemouth.—Due to postal delays last month's notes unfortunately arrived too late for inclusion. The local T.R., 2HNO, contracted rheumatism, whilst spending nights in the rain with the H.G. An anticipated visit from VK3XE and VK2ADE did not materialise. Best of luck to 3789, who has gone to Sheffield. Things are levelled up, however, because G3VY is welcomed from that city. The latter has recently left hospital and is hoping to make a few ham visits shortly. 3BM has acquired a new receiver. 2NS has moved again and would be glad to hear from any of the old District 7 gang at 26 Southsea Avenue, Bournemouth.

Croydon.—G4AA is now an L.A.C. and well on the way to recovery after an accident. 2FWA keeps a watch on 28 Mc. with his one-valve receiver. 3179 finds that DX does not figure in the curriculum of the R.C. of S. BRS3003 is disappointed with poor conditions on 28 Mc. Regular meetings of the S.R.C.C. have had to be abandoned temporarily, but impromptu gatherings still occur at coffee time. 2FH, 3IG and 5XH remain active.

Portsmouth.—G2KU, an "exile" from Croydon, sends the following notes from 105 Clarendon Road, Southsea, where he would like to meet Service members. He has already had visits from VE's 2QH, 3RS, and 5CV. Hopes of further informal meetings, including VU2BY and VE4IG, are entertained. Congratulations to 8MO, who has been promoted to sub-lieut. 2BGH has designed a novel morse instructor. 3KZ finds H.G. more interesting now that he has discovered two hams in the unit. 2KU has completed a new receiver and a U.H.F. convertor.

Guildford.—G6GS made a welcome return to the town whilst on leave. Congratulations to G5YA, who has accepted a commission. G8LT, whilst on leave, imparted the information that G2PL (a frequent visitor to this area) was recently presented

with a second op. Nice work, Peter. (District 8 also got the news!!—Ed.) Best of luck to 8IX, who has joined the R.A.F.; his address can be obtained from 5WP. 5CM is still very busy with the receiver, and sends 73 to the gang. 5WP is giving morse lessons to some of those awaiting call-up.

G5WP.

DISTRICT 8 (Home Counties)

This month we have to report more members leaving the district to join the Services, or to work elsewhere. It seems, therefore, that we shall have to rely more and more upon the post to bring us news of their activities, so here's hoping they won't forget to write occasionally.

Cambridge.—The only resident members, now, are G2XV, 5BQ, 5JO, 8SY, and we believe 3CY, although he has not been seen for some time. 2XV, ever optimistic, has snapped up some useful bargains ready for building a post-war super-station. 5JO often yearns to let go another broadside on 7 Mc. 2PL, recently visiting from London, is now, we understand a proud father 5DQ was looking very fit when home on leave. 5DR is still in the land of banks and braes.

St. Ives.—G6WA recently home on leave from the R.A.F. is a W/Op. and is getting on well. 6DX who has also been home on short leave, is now a sergeant, and has his A.G. half-wings. 4AZ is living at Carlton, Beds. until December 6, when he returns to a new house at Fenstanton. Dick Williams, of Swavesey, is in Northern Ireland, and has sent home for his call-book, preparatory to a round of visits. (Not necessary O.M. Just call at Y.M.C.A. Radio Club, Belfast.—Ed.) Peter Shenton of Graveley is in the R.A.M.C. XZ2DY was O.K. when last heard of at Maymyo, Burma. 8ST has gone abroad, and 5RL to whom we are indebted for all this information, has now been called up for the R.A.F. (Good luck, and thanks, O.M. for co-operation.)

Peterborough.—A really sad blow has fallen, for our indefatigable T.R., Bill Carter, G2NJ, has departed to take up work elsewhere. Though his QRA will have changed, ours will be the same, so we hope to hear from him just as regularly. 2UQ has joined the R.A.F. as a radio-mechanic. 3WW recently visited Cambridge, and reported, "All well with 3 BK, and self." 2XV called on 3DY, who is going strong, but would like to see the old neon tube lighting up again!

Luton and Bedford.—No news from this area. Is there no one who will let us have tidings of the locals?

Since the above notes were written, a letter has arrived from W. T. Pickard (G8KP), of Wakefield, now stationed in Beds. who sends news of G4OC 2DPQ, and 2DTD. 8KP well known to Cambridge amateurs, hopes to pay the town a visit shortly. G5BQ.

DISTRICT 9 (East Anglia)

It seems that at least some members are still at home, and we are indebted to G6QZ, 2FAO and BRS3821 for a few hints as to where all the others have gone to. 2FAO's work with the R.A.F. seems to take him around the District, and we are glad to hear that he has made personal contacts with 2BXJ, 2HFK, BRS3434 (Yarmouth), 5QO, 2CWO

(Lowestoft) and with G5WW, 4FS, 6QB, 4JO and STX elsewhere.

G6QZ (Norwich) has recently been visited by 5IX, who is stationed nearby, whilst 2 MN is still carrying on as usual.

BRS3766 and 3821 (Yarmouth), who are finding time for a certain amount of experimental work, send 73 to 3RW, 2HFK, BRS3468 and 2999, who is now in Notts.

G5UD, who is stationed in the West, rang G2XS to say that he hopes to visit him in November. 6FB is still ploughing the seas in a warmer climate than this. Incidentally, what has happened to that ham who is stationed near King's Lynn and who was going to look in on G2XS? (Possibly posted elsewhere.—Ed.)

G2XS.

DISTRICT II (North Wales)

Mr. David Mitchell, GW6AA, has asked to be relieved of his duties as D.R. until after the war. In accepting his resignation *pro tem* we extend our warm thanks to him for his past services to Council and to our members in North Wales. G6CL.

* * *

From Prestatyn, Mr. C. Spillaine, BRS1060, "Woodside," Meliden Road, reports having contacted several service members including G2KI and BRS1066. Most of the well-known Prestatyn amateurs are now working in other parts of the country, but the newer members GW3CF, 4CK and 2HIY, are co-operating in extending "Ham Hospitality." Informal meetings are held at BRS1060 every Tuesday and all members are welcomed.

DISTRICT I2 (London North and Hertford)

We are pleased to report that letters have been received from G3LT, 3NR, 8CK and BRS3760—it's a good start fellows, but you *can* do better if you try! Seven members attended the meeting held at G5FA last month and thoroughly enjoyed a good ragchew.

G3LT, who manages to spend part of his time in the den improving his receiver and audio equipment, reports the following members of the Edgware S.W. Society are now serving in H.M. Forces, G3HT, 4FZ, 4GB, 4KD, 4JU, and 6ZO. G3II who recently moved to Kingston asks to be remembered to his friends in North and North-west London, as do G3HT and 4KD. BRS3760, at present serving with the R.A.F. as a radio mechanic, would be grateful to any member who can spare a few technical magazines. His QRA may be obtained from G5FA. G3DT was very surprised to meet 6OT in the Orkneys recently and sends 73 to all old friends. Visitors to our last 7 Mc. N.F.D. site will be interested to hear that 2FVX is now spending his nights there endeavouring to get more sleep. We hope he is keeping the ground "radio active" for our next field day!

G8CK, who sends news from the Watford area, says G3KP has made a crystal set for the dugout, while 2HAR is rebuilding his Sky Champion and constructing a super straight receiver, frequency meter and monitor. G8CK, 4BY and 3OJ recently had a grand time together and are looking forward to another occasion when they can whirl round the bands on 3OJ's RME 69 plus DB20.

G3NR, also of the Watford area, writes giving details of a very ambitious S.S. superhet receiver which has kept him busy for the past year. It has been built into two units, the second of which contains a crystal bandpass filter operating at 465 kc., and has provision for plugging in pairs of crystals for variable bandpass separation. These give a bandpass of 3 kc, 1 kc. and 200 kc. The crystals were home made and necessitated the construction of a polariscope, cutting wheel and lap for grinding.

Both machines were made from an old bike, the remainder of which he hopes, has by now been dropped on Hamm! An RF unit covering 1 Mc. to 120 Mc. calibrated at 1 Mc. by a crystal oscillator and a DF unit have also been constructed. He is now in the process of building a UHF adapter to go in front of the super to cover from 60 to 300 Mc. (What about some BULLETIN articles O.M.)

As mentioned last month the next meeting will be held at war-time H.Q's—G6CL—at 3 p.m. on November 17. G5FA.

DISTRICT I4 (Eastern)

Chelmsford. — Local amateurs held their first meeting of the winter session at G6LB on October 7, when G5RV, 5CA, and BRS3650 defied the siren to attend. A proposal to hold future meetings on the first Sunday morning in each month was carried. G5RV brought along volumes of *The Wireless World*, dated 1913 to 1915 and much interest was provoked by reading extracts from them. Comparison of modern amateur practice with that of the years preceding the last Great War was of great interest. Local members send greetings to their brother hams in the Services.

Captain H. G. Mappin, R.C. of S., G3BS, called on 5RV and 6LB recently to swap DX reminiscences and to drink a toast to victory! 2SA continues to do yeoman work in the Home Guard. Lt. Gordon Hill, R.E. G2KG, paid a brief visit some weeks ago and recounted many amusing incidents of life in the army. We understand he is due for his third pip shortly. Good luck O.M.

East Essex.—G2SO regrets he has been passed as unfit for Military service with the R.A.F.(V.) R. With 3OA they represent the last of the civilian active members in this area and owing to travelling difficulties are unable to attend meetings elsewhere. G6UT.

DISTRICT I5 (London West, Middlesex and Buckinghamshire)

So far no one has come forward with any suggestion for further meetings and the D.R. has not been able to find sufficient time to get around to look for alternate accommodation.

No reports have come to hand but the D.R. has, during the month, seen a few members. One or two have suffered as the result of air-raids, but so far as is known there are no casualties.

Letters have been received from Chas. Kirk (G4CL) who wishes to thank District members for the nice tea and the autographed copy of the Handbook with which he was presented at our September meeting. He also wishes to thank G8KZ for showing him around town and conveying him to G2YL. It seems that he had a rather rough passage during the following week, on his way back to York—he says he *nearly* got some sleep one night and by the time he did get back he was almost afraid to go to bed!

A second letter comes from G8GG TR for Blackpool, who is in the R.A.F. and stationed within the district together with 2BVN. Also in the same area are G8PY and 2FVH with the R.C.S. The D.R. hopes to have the pleasure of meeting them all soon. Any other member willing to make arrangements to meet them should write to G6WN for the address to make contact. G6WN.

DISTRICT 16 (South Eastern)

Reports from T.R.'s and members have fallen off recently and none have been received this month. We feel that many of those who are serving outside the District look to this page for news (however scanty it may be) of their brother-members who are still in the South East. Therefore, it is up to us to see they are not disappointed.

May we ask all District 16 members, whether at home or away, who read these notes prior to November 25th, to send a card to G2WS at 8 Beckenham Grove, Shortlands, Kent. Arrangements will then be made to see that every communication received is mentioned in the December BULLETIN. We are sure that at the season of greetings many would welcome news of old colleagues and perhaps a word or two about their present activities. Will T.R.'s please help by sending any news they have of members in their areas?

Remember that it takes more than annual subscriptions to produce that most welcome of all publications—the "Bull!" G2WS.

DISTRICT 17 (Mid East)

Our D.R. Mr. W. Grieve, G5GS, Summerford, New Waltham, Lincs, writes to say that most of the District members are now on active service. Old stagers such as G5BD, 5CY and 6LI are doing odd listening but meetings are out of the question for the time being.

Friends of J. Cory, G5CY, will join us in offering him congratulations on his recent marriage.

G5GS is busy on Government contracts but fits in an odd hour on his receiver when time permits. News from members in and out of H.M. Forces will be welcomed by the D.R.

DISTRICT 18 (East Yorkshire)

We are pleased to give publicity to the following brief notes received from Mr. J. M. Abbott, G8UL, 48, Sunny Bank, Hull.

We extend our best wishes to G6OY who, as announced last month has joined the R.A.F., and to G5MN who is awaiting his call for duty in the same service.

If Hull area notes are of interest to local members, will they please turn to G6CL's editorial in the September issue, and remember news depends on them.

Come on fellows it's up to YOU.

* * *

The Scribe and T.R. for Scarborough, G6TG, having left the town, has had to relinquish the positions. He spent a few days in the R.A.S.C. before being released for civilian work with the R.A.F., and is now stationed in the north of Scotland. All in the District are thanked for their co-operation in gathering together local notes during the last two years. Letters can be sent via Grimes Hill Lodge, Middleton, Nr. Kirby Lonsdale, Westmorland.

G6TG.

Scotland

In an endeavour to gather more news for these notes, we appeal to members in the larger centres of activity to volunteer as District Scribes. The only duty required of them would be to furnish once a month any news suitable for incorporation in the notes. We trust that next month we shall be able to include the results of this appeal.

"A" District.—There was a fair attendance at the October meeting when Mr. James Hunter, GM6ZV, delivered his talk on a "100 kc. Frequency Sub-standard," after which a discussion took place and many interesting suggestions were made relative to the construction of these instruments. Prior to the talk, there was a "junk" sale and the sum of 12/- was realised. The "junk" consisted entirely of some extremely useful receiver components donated by Mr. Crate, BRS2671, who directed that any sum realised should be credited to the District N.F.D. Fund. Mr. Crate's gesture is appreciated by the members, who send him their thanks.

Jim Troy, GM8RJ, who has been home on leave for a few days, wishes to be remembered to old friends. Greetings to members come from Don Duthie, GM6IW, who is abroad, and also from Jim Emerson, GM8HA, particularly to GM6JD, 2CHN, GM5ZX and GM8HJ. The date of the November meeting is the 17th, but as the BULLETIN will most likely not have reached members by then, no detailed announcement is made. We remind members, however, that "A" District meetings are held on the third Sunday of each month, at 2.45 p.m., in the Coffee Room, Y.M.C.A. Residential Club, 100 Bothwell Street, Glasgow. All members who are in Glasgow on these days are heartily invited to attend.

* * *

Apropos the remarks made at the commencement of these notes we learn with much pleasure via G6CL that F/Lt. W. Craig, GM6JJ, has offered to forward notes and news from East Scotland. Reports should be sent to his home address "The Manse," Fort Rose, Ross-shire, by the 24th of each month. GM6ZV.

Northern Ireland

It is very much regretted that, due to Censorship delays, our notes for the October issue arrived too late for inclusion. As readers will have seen from the "Stop Press" notice in that issue, the notes took *eleven days* to travel from Belfast to London! We always said London was DX for those of us who worked in peace time on . . . Metres!

Amateur radio continues to flourish in Northern Ireland and the writer hopes that all who can do so will send notes and news for these columns so that we can truly prove that it is flourishing.

During recent weeks many of our service friends from G, including G8DI, 3BR and 3AH, have left us. Newcomers are Lewis Scholefield (G5SO), Donald Rock (G8DR), P. Halligey (G8PI), W. T. Rees (GW3CR), E. Ratcliffe (2DXA), J. A. Bousfield (2FQQ), V. W. Soven (2BYC) and W. D. Mason (G8PW). Two of our latest visitors were indeed DX, Ted Bracher (ZS2P) and Donald Rex (ZS2BU), both of whom hail from Port Elizabeth, South Africa. Before joining up in the S.A.R.N.V.R. they were near neighbours.

We are glad to record that 2DGU who was seriously ill is now on the mend, as is G8SM who has been down with flu. Perhaps it is only a coincidence that both were recently married! Congrats are offered to G18GK and 6TK on the arrival of Junior Ops.

BRS2744 and 2754 have constructed new receivers which are being put to good use. Many others, including 3JP, 3ZY, 5TK, 6WG, 8LF and 2DHB are doing a spot of listening.

G15TK, who lives in a lovely part of the country, was recently pleased to welcome G3RF, G15HU and G15UW. G15QX continues to extend hospitality at his shack at all hours of the day and night.

The D.R. has had the pleasure of receiving a visit from 2FQQ, who is in the Navy. G15SJ and 6TK are in the same L.D.V. unit, whilst 2FHN has joined the R.A.F. as a wireless mechanic.

Belfast Y.M.C.A. Radio Club

ANNUAL MEETING.

THE Seventeenth Annual General Meeting of the above club was held in the clubroom on Wednesday, September 11, 1940. Those present included G3IY, 5SO, 2YN, 6KS, 3OI, 8PI, 8PR, 3BR, G15UW, 3KV, 6TK, 8GK, 5HU, 2HCC, 2BNM, 2HMQ, 2DXA, 2CHJ, 2AMW, 2DHU, BRS2744, 2754 and BSWL330.

In the absence of the Chairman (Mr. J. Gallagher, 2CIZ), Mr. W. E. Davey, B.A. (BSWL330) was unanimously called upon to preside. He welcomed the visiting amateurs and requested that they should invite to the clubroom anyone whom they knew to be interested in amateur radio.

After other business was attended to, Mr. F. A. Robb (G16TK) submitted the annual report and financial statement. The report mentioned that the membership had risen to over 90; that the W.A.C. Certificate had been issued to G16YM; and a new Sky Champion had been installed in the clubroom. Experiments with receiving aerials had also been carried out with a view to eliminating interference. The club has now its own directory whereby visitors may see at a glance where any G1 amateur resides.

Later News

John Graham (GM3TR), after visiting G and GM, has now returned to Belfast. EI8F is also in the town for duration. Recent service visitors included Maurice Dalton (G8PW), A. H. Broomfield (G6OQ) and J. R. Senior (BRS3582), all of whom are in the R.N.V.(W.)R. Others welcomed were G8IY, 2BWF, 2BYC, BRS2770 and VE1IY. The latter is with the Canadian Air Force.

G16VG has paid a visit to the Y.M.C.A. Radio Club after being away for nearly nine years. Two old timers, G16NY (who was one of the founders of G16YM) and G12BB are back in the ham world.

It is hoped that all amateurs who visit Belfast will make a special point of visiting the Y.M.C.A. Radio Club. Meetings are held on Wednesday evenings. G16TB.

A diagram of the roads from G16YM to the shack sought for, and in most instances a photograph of the amateur concerned, are included along with other information relating to a particular station. It was reported that Mr. W. E. Caughey (2DZG) R.C. of Signals who was for a period Hon. Secretary to the club, was a prisoner of war in Germany.

Amateurs with H.M. Forces who are visitors to Northern Ireland are made honorary members of the club during their stay in the Province—three such members were elected to office.

The office bearers for the ensuing year are:—President, Dr. Andrew Trimble, J.P.; Vice-President, Mr. W. E. Davey, B.A.; Chairman, Mr. A. T. Kennedy (G13KN); Vice-Chairman, Sgt. S. W. Clark, R.A.F. (2AMW); Hon. Secretary, Mr. R. S. Holden (G15HU), 260, Grosvenor Road, Belfast; Hon. Treasurer, Mr. Frank A. Robb, (G16TK); Committee: Messrs. S. H. Pattison (G15UW), Sgt. Frank Adams, R.A.F. (G2YN); Cpl. A. Donald Rock, R.A.F. (G8PR), and H. Carmichael (2CHJ).

G16TK.

War Damage Claims

Mr. R. Parsons, G6RP, 35 Liberia Road, Highbury, London, N.5 who is an architect by profession, will be pleased to give free advice on procedure to any member wishing to lodge a war damage claim. He can be reached on Canonbury 3529.

Angler's Corner

Every week a prominent Belfast newspaper publishes notes and news concerning amateur radio activities in the Province. One week recently, due to a printer's error "Angler's Corner" was substituted for the normal heading!

We are tempted to wonder whether this "error" was not deliberate, especially if the Editor had heard some of the fisherman's tales related at the Y.M.C.A. Radio Club!

Remagnetising Headphones

From time to time we receive inquiries from members for advice on remagnetising headphones. There are probably several simple methods, but we should like to hear of one which can be adopted from the sort of junk gear lying around the average amateur's den. Has anyone a Bright Idea to contribute?

Every Renewal Reminder
COSTS MONEY AND WASTES
TIME AT HEADQUARTERS
PLEASE PAY YOUR SUBSCRIPTION
PROMPTLY WHEN DUE

Book Review

INTRODUCING RADIO RECEIVER SERVICING. By E. M. Squire. Published by Pitman, 6s.

It has been left to the author of this new *Pitman* publication to fill a gap which has gradually been widening in recent years. That gap has been brought about by the introduction into the field of radio servicing, of a large number of men who have, to quote an old tag, "not been brought up in the hard school of radio experience."

The present book is intended to provide an introduction to the practical operation of a receiver, but it goes much further than that avowed object. For example, Chapter 5 "Radio Receiver Circuits and how to read them" contains more useful information per page than is to be found in many much more comprehensive volumes.

Beginning with a short general survey of receivers, the reader is then given advice on resistors, coils, condensers and transformers. Chapter 4 deals with the operation of thermionic valves, while later chapters are devoted to the Radiogramophone, and Radio Servicing Equipment.

The concluding Chapter entitled "Tackling the First Service Job" could perhaps have been improved by the inclusion of a list of typical faults and their cures, but possibly the author considered that this aspect is adequately covered in the more advanced Servicing manuals.

There are 106 well executed diagrams illustrating the text, which occupies 97 pages.

Without doubt this book meets a growing demand, and should prove of especial value to the many young men fresh from school, who are taking up a career as radio service engineer. J. C.

1941 Diary.

Collins Wireless Diary (price 2s. 0d., obtainable from booksellers), makes its customary appearance bound in green imitation cloth. Over 120 pages are devoted to electrical and radio data and it is interesting to note that pride of place in this galaxy of information is taken by a table of Amateur frequency allocations. Prefixes, Q Code and Signal Report Codes are also included. Log, Antilog, and other useful tables, together with well-written notes on Direction Finding, Television, Production of H.F. Oscillations, A.C. Circuits, etc., go to make up what is without question a most useful diary for the radio amateur. The diary entries are one week per opening. J. C.

INDEX TO DISPLAYED ADVERTISEMENTS

A.C.S. Radio	162
Automatic Coil Winder and Electrical Equipment Co., Ltd.	Cover ii
British Mechanical Productions, Ltd. (Clix)	161
Brookes Measuring Tools	161
Bulgin, A. F., & Co. Ltd.	138
Candler System Co.	127
Celestion Ltd.	137
Electradix Radios	126
G5NI (Birmingham) Ltd. (Radiomart)	Cover i
General Electric Co., Ltd.	138
Goodman's Industries Ltd.	125
Hulton Press Ltd.	Cover ii
Leonard Heys	162
McGraw Hill Publishing Co. Ltd.	127
Piezo Crystals Co.	138
Pitman's	162
Premier Radio Co.	Cover iii
Quartz Crystal Co., Ltd. (Q.C.C.)	161
R.S.G.B.	128
Stratton & Co., Ltd. (Eddystone)	144
Taylor Electrical Instruments, Ltd.	126
Webb's Radio	Cover iv

Band Pass Filter Crystals



Ground to any specified frequency between 440 kc., and 500 kc. and supplied in selected pairs to give any desired band width from 200 cycles to 10 kc.

PRICE PER PAIR
mounted in compact
air gap holder
£1 17s. 6d.

Single crystals for any frequency between 440 and 500 kc., for use in the Lamb type filter can be supplied mounted in the normal $\frac{3}{8}$ in. pin spacing plug-in holder at **£1 7s. 6d.** each.

The QUARTZ CRYSTAL CO., LTD., Kingston Road
NEW MALDEN, SURREY. Telephone: Malden 0334

CLIX

FLEXIPIN Self-Adjusting PLUGS

If your radio **CRACKLES** when you touch the plug which connects your set to the wall socket, it is because the plug-pins are not making proper contact with the socket-tubes.

The CLIX plug has been specially designed to eliminate this trouble and its self-centering, expanding pins will fit and make perfect contact in any make of B.S.S. Socket.

CLIX 5 amp. 2-pin "M" type plug as used by all the leading radio manufacturers.

COSTS ONLY **4 $\frac{1}{2}$ ^{D.}**



A full range of 2 and 3-pin B.S.S. types in 2, 5 and 15 ampere sizes is available from all good radio and electrical dealers.

If in difficulty write to the makers:—

BRITISH MECHANICAL PRODUCTIONS - LTD.

1 Church Road, Leatherhead, Surrey

FIT "CLIX" and CUT THE CRACKLE

GOERING'S next move— not ours*

COMMUNICATION RECEIVERS

We can still supply new American models for H.M. Services, and also have a few shop soiled or slightly used models for private purchase.

We are also seeking to purchase for cash, good modern American Communication Receivers, especially National. Why not let us make you an offer? A fair and square deal assured.

RECONDITIONED All-Wave RECEIVERS

Have you seen our current bargain list? Excellent value offered. Inspection invited. We also offer a good range of American type valves, components, meters, etc., and a selection of new and reconditioned Recording equipment.

*Please Note: We are still at No. 44.

A.C.S. RADIO

44 WIDMORE ROAD, BROMLEY, KENT.
Phone & Grams: RA Vensbourne 0156. Close Wed. 1 p.m.

VALVES — AMERICAN & BRITISH TYPES

— LARGE STOCKS CARRIED —

Send enquiry (on your trade stationery) together with 2½d. stamp for our

16-page "VALVE COMPARATIVE CHARTS and PRICE LIST"

(Reviewed in October "T. & R. Bulletin," page 99)

LEONARD HEYS FARADAY HOUSE

36/38 Henry St., BLACKPOOL, LANCs. EST.: 1922

CRYSTAL CONTROL

FOR ALL—

BAND.		ACCURACY.
(a) 1.75 Mc. ...	16/6	± 1 kc.
" 3.5 and 7 Mc. ...	15/-	± 2 kc.
" 14 Mc. ...	30/-	± 5 kc.
(b) 100 kc. ...	15/6	± 0.1 kc.
Temp. Coeff. (a)—(23 × 10 ⁶)		
(b)—(5 × 10 ⁶)		

Enclosed Holders, plug-in type, suitable all bands, 12/6

BROOKES MEASURING TOOLS,
51-53 Church Street, Greenwich, London, S.E.10
Tel.: Greenwich 1828

RADIO BOOKS

INTRODUCING RADIO RECEIVER SERVICING

By E. M. Squire

An informative guide for those training to be radio service engineers or testers. It deals first with the receiver as a whole and then successively with the various components, devoting a complete chapter to the valves. Other chapters deal with the reading of circuit diagrams, the special features of radio-gramophones, and how to use radio servicing equipment. A final chapter shows how to carry out a typical service job. 100 pages. Over 100 illustrations. 6/- net (by post 6/4).

PITMAN, Parker Street, Kingsway, London, W.C.2.

GET ONE OF PITMAN'S

"THE T. & R. BULLETIN"

ADVERTISEMENT RATES

FULL PAGE (ordinary position) ...	£5. 0.0
HALF PAGE " " ...	£2. 10.0
QUARTER PAGE " " ...	£1. 5.0
EIGHTH PAGE " " ...	15.0

No Series Discounts allowed.

For covers and specified positions an additional cost of £1 per page and pro-rata.

NOTE: These rates are still £1 per page below the pre-war level.

Exchange and Mart rates:—

MEMBERS private advertisements, 1d. per word; minimum charge, 1/6.

TRADE advertisements, 2d. per word; minimum charge 3/-.

TERMS Cash with order.

All communications to:—

PARRS ADVERTISING LTD.
121 KINGSWAY, LONDON, W.C.2

Telephone: HOLborn 2494

Advertisement Managers to The Radio Society of Great Britain

HEADQUARTERS CALLING

A.R.R.L. Handbook (1941 Edition)

Advice has been received from the A.R.R.L. that the 1941 edition of their Handbook was placed on sale on November 1. The new books runs to about 600 pages and weighs nearly 2 lbs.

The A.R.R.L. has been forced to increase its charge to the Society for individual orders, consequently we have with reluctance been compelled to raise our price to 10/- per copy post paid.

"Radio" Handbook (1941 Edition).

From the October issue of *Radio* we learn that the 1941 *Radio Handbook* was published on November 1. This edition, which is unique, in that it is in a cloth bound cover, contains over 600 pages, including 24 pages of valve data.

Orders will be accepted by Headquarters on the same terms and conditions as those which apply to the A.R.R.L. Handbook. The price is 10/6 and delivery will be made direct from America.

Christmas Orders.

Although a full month remains before Christmas, Headquarters recommended that Sales Dept. orders, intended for Christmas gifts, should be given as early as possible, to avoid delays during the holiday period. In particular Call Sign Badges and Car Plaques with call sign should be ordered not later than December 1.

Members who wish to send Sales Dept. items (including the Handbook) to friends in the Services may forward a greetings card with their order and Headquarters will then arrange for direct delivery to be made in time for Christmas.

Overprinted Members Notepaper.

Arrangements have been made for members notepaper to be overprinted with name, address, telephone number, and pre-war call sign. The price per 100 sheets is 8/- or 12/6 per 200 sheets, post free.

Ham Hospitality

We are pleased to give publicity to the following additional names of members who have kindly offered to extend "Ham Hospitality."

OXFORD.—W. E. Beck (2ALG), 31 Ridgefield Road, (Oxford 47703 during business hours).

STOCKPORT.—C. Lingard (G3IR), Alasdair, Chester Road, Poynton (Poynton 2087).

SWANSEA.—W. S. Hall (2AOL), 58 Newton Road, Mumbles.

* * *

Our old friend Jim Corbin, VK2YC, wishes us to state that a most cordial welcome will be extended to any G Ham who finds himself in the neighbourhood of his home town—Sydney, N.S.W. Jim's telephone number is Mascot 560 and his full address 78 Maloney Street, Eastlakes, via Mascot.

A similar welcome will be extended to visiting amateurs by Mr. Wal Ryan, VK2TI, Hon. Secretary, W.I.A. (N.S.W.) Division. Phone FX3305.

District II Representative

Due to pressure of private business, our North Wales D.R., David Mitchell, GW6AA, feels compelled to relinquish his office *pro tem*. It is hoped to announce the name of a District Scribe in our next issue.

Returned Bulletins

Readers are asked to assist us in tracing the present whereabouts of the following members who have moved from the address recorded at Headquarters:—

A. B. Boswell (G3DA), 2 Beech Avenue, Higher Irlam, Manchester.

G. G. Eastwick-Field (2FNM), Prior's Hatch, Godalming, Surrey.

K. N. Franklin (G2SJ), 152 Longcroft Lane, Welwyn Garden City.

P./O. F. Inchley (G3AG), R.A.F.

F./Lt. A. W. Langton (G4MP), Wyken House, Links Road, Kirby Muxloe, Leics.

A.C.2 W. H. Nuttall (2AGP), R.A.F.

G. E. Oakley (G5OA), Thames Bank House, East Greenwich, S.E.10.

A. J. Stephens (G3NO), Hilltops, Englishcombe Lane, Bath.

J. E. Tompkins (G6ZF), 33 West Hill, St. Leonards-on-Sea.

J. W. Turton (2DTV), 59 Marple Street, Alfred Street, Nottingham.

R. N. Wellington (BRS1279), Sound Sales Ltd., Tremlett Grove, Highgate.

New Members

W. BOWEN (GW4CC), Thistledhu, Upper Killay, Swansea.

R. LANSLEY (G4KV), 27 Bascott Road, Wallisdown, Bournemouth.

E. H. RUTLEDGE (2FAM), 5 Wharram Street, Hull.

D. F. SULLIVAN (2FCJ), "Holcombe," Bryn-Marle Rd., Mochdre, Nr. Colwyn Bay.

R. W. WILLIAMS (2HAK), 64 Stour Road, Christchurch, Hants.

G. R. STRODE (BRS3861), 24 Keys Avenue, Horfield, Bristol 7.

R. C. M. YOUNG (BRS3862), Formosa Fishery, Cookham, Berks.

A. REDMAN (BRS3863), 16 Ashfield Terrace, Bingley, Yorks.

S. H. JONES (BRS3864), 51 Lakefield Road, Llanelly, Carmes.

Major H. C. B. ROGERS, O.B.E. (BRS3865), R.C. of Signals.

R. ROSE (BRS3866), 212 Spies Lane, Quinton, Birmingham 32.

J. J. B. PAINE (BRS3867), 38 Alpha Street, Slough, Bucks.

L. A. SPONG (BRS3868), 112 Brighton Road, Sutton, Surrey.

Wing Comdr. F. G. H. EWENS (BRS3869), "Fairfield," Hinksey Hill, Oxford.

M. RADLEY (BRS3870), Rathkeale, Ffriddoedd Road, Bangor, Caernarvon.

R. A. WATSON (BRS3871), 6 Milton Avenue, Kingsbury, N.W.9.

J. A. GOUGH (BRS3872), 40 Lostock Road, Davyhulme, Urmston, near Manchester.

R. S. EVANS (BRS3873), Drayton, Penns Lane, Erdington, Birmingham 24.

C. A. WOOLGER (BRS3874), Somerford, Hants.

Returned Bulletins

Dozens of Bulletins are being returned to Headquarters each month because members have moved without sending advice. Please co-operate by sending us your change of address promptly.

EDITORIAL.—(Continued from page 129)

television stations within our recognised frequency assignments.

It may be remembered that some years ago British amateurs were given an allocation just outside the 28 Mc. band for television experiments. It seems to us that if, after the war, this latest development "catches on" in Great Britain our authorities would be well advised to place amateur Television stations in a "world apart" from those who are Disciples of the Key and Mike.

What sayest thou?

J. C.

A FREQUENCY METER OF NEW DESIGN.

(Continued from page 133).

readings are to be taken at long intervals, and in any case each time the instrument is switched on.

The whole instrument may be housed in a suitable metal cabinet, and the design has been arranged for this refinement. If this is done, and the instrument is left undisturbed, its calibration will remain fairly constant, and its stability will be found to be of a high order.

It should be pointed out that the accuracy of the instrument is limited by the accuracy of the sub-standard check, and may be taken as being in the order of .01 per cent.

Multi-Vibrator

In response to several requests, the design of a suitable multi-vibrator for use in conjunction with the frequency meter will be presented in an early issue.

WINGS OVER THE TUMULI.

(Continued from page 151).

The meeting concluded after the Chairman had expressed, on behalf of all present, thanks to P/O Hubbard for his valuable co-operation.

Among those known to be in attendance were:—GW2WO, 3AM, 3JR, 3MX, 3VI, 3XP, 3ZQ, 4BQ, 4HK, 4JI, 4DS, 5JB, 5JR, 5JU, 5LB, 5OX, 5PN, 5UK, 6HY, 6WL, 8DU, 2AZI, 2CJT, 2CNX, 2BGI, 2FQW, 2FTN, 2FXU, 2FXX, 2HCW, 2HKS, BRS. 935, 3763 and OK2HY, and at least another dozen interested non-members.

It was agreed to meet again on November 10 at the same time and venue. F. C. T.

News from British West Africa

Congratulations are extended to ZD2G on the occasion of the birth of a junior op. and to ex-VQ3FAR, now stationed in ZD2, on his recent marriage. In a personal rag-chew with ZD2H, FAR bemoaned the fact that the ban came when he was contemplating starting up under a ZD2 call sign. No news is available of ZD2KM or BERS440. What about a line, chaps?

ZD2H recently renewed his acquaintance with ZD4AB over a commercial circuit, a long way removed from 14 Mc.! It was unanimously agreed to renew their previous Sunday 7 Mc. sked as soon as possible after the cessation of hostilities.

Amateurs stationed in this part of the globe are asked to drop a line to A. Tomlinson, ZD2H/G2QN, c/o Posts and Telegraphs, Lagos, marking their letters "Please forward!" It may then be possible to get acquainted and perhaps to send more regular and detailed notes to the "Bull." ZD2H.

Two Useful Books

Mr. E. H. Simmonds, G8QH, reminds us that the current edition of *The Admiralty Handbook* (published in two parts, price 4/- and 6/- respectively), is a storehouse of first-class material bearing closely on amateur problems.

He also finds that Mr. Scroggie's *Radio Laboratory Handbook* provides much useful data for those who have the time for constructing test gear.

EXCHANGE AND MART.**Advertisement Rates**

MEMBERS' private advertisements 1d. per word, minimum 1s. 6d.

TRADE advertisements. 2d. per word, minimum 3/-

TERMS: Cash with Order.

All copy and payments to be sent direct to Advertisement Managers, Parrs Advertising Ltd., 121 Kingsway, London, W.C.2, by the 30th of the month for following month's issue.

ALL KINDS of PRINT. Send your enquiries to G6MN, Worksp.

EXCHANGE.—First 40 parts "Harmsworths Pictorial History of War," new condition. Collection of 111 Canadian stamps, all different, including many complete sets. Want Panel meters, Test meter, or what have you.—BRS3852, 99 Woodfield Drive, Romford.

FOR SALE.—Howard 460. Complete with speaker and phones. Brown lightweight. Crystal filter, Built-in frequency monitor. New.—R. S. HALL, 119 Dorchester Road, Leicester.

WANTED.—Communications receiver, in good condition, for cash. State specification, frequency range, condition and price.—H. F. BRIGGS, 3A Romney Park, Dalton-in-Furness.

WANTED.—Eddystone Microdenser No. 1130, capacity .00016 mfd. Must be in new condition.—WESTLAKE, "Ardlui," Wenlock Road, Shrewsbury.

WANTED.—Small Communication Receiver in good condition. State price, usage and full particulars to C. SHARPE (2HIF), 20 Park Road, Swanage, Dorset.

1939 Howard 438 model Communication Receiver, crystal filter, separate "R" meter, 7½ to 550 metres. Little used. Cost £20 10s., accept £15.—G5QG, Police Station, High Street, Harborne, Birmingham.

PATENTS AND TRADE MARKS

KING'S Patent Agency Ltd. (B. T. King, G5TA, Mem. R.S.G.B., Reg. Pat. Agent), 146a Queen Victoria Street, London, E.C.4. Handbook and Advice on Patents and Trade Marks free. Phone: City 6161. 50 years' refs.

RADIO MAP AND GLOBE

WEBB'S RADIO MAP of the World enables you to locate any station heard. Size 40" by 30". 2-colour heavy Art Paper, 4/6, postage 6d. Limited supply on Linen, 10/6, postage 6d. WEBB'S RADIO GLOBE—superb 12" full-colour model Radio prefixes, zones, etc. Heavy oxidised mount. Post paid, 27/6.—WEBB'S RADIO, 14 Soho Street, London, W.1. Phone: Gerrard 2089.

PREMIER RADIO

PURCHASE TAX.—We have sufficient stocks of all taxable radio goods (with very few exceptions) for a reasonable period. When these are sold tax will become operative. Purchase now and save money.

PREMIER 1940 "5V5" COMMUNICATIONS RECEIVER

A 5-valve Superhet, covering 12-2,000 metres in 5 wave bands.

- Beat Frequency Oscillator
- Band-Spread Control
- A.V.C. Switch
- Illuminated Band-Spread Dial
- Send-Receive Switch
- Iron-Cored IF's
- Phone Jack
- Over 4 Watts Output

Provision for single wire or Dipole Aerial. International Octal Valves for 200-250 v. mains (A.C.). Built into Black Crackle Steel Case providing complete screening, 10½ in. Moving Coil Speaker in separate steel cabinet to match. Receiver. Complete with all tubes and Speaker ... £9.9.0

AMERICAN VALVES

We can still supply all types at competitive prices.

SHORT-WAVE GEAR

Short-Wave Coils, 4- and 6-pin types, 13-26, 22-47, 41-94, 78-170 metres, 2/- each, with circuit. Premier 3-Band S.W. Coil, 11-25, 19-43, 38-86 metres. Suitable any type circuit, 2/11.

4-pin or 6-pin Coil Formers. Plain or Threaded, 1/2 each.

Utility Micro Cursor Dials, Direct and 100:1 Ratios, 4/3.

Bakelite Dielectric Variable Condensers. .0005 mf. Suitable Tuning or Reaction, 1/6 each.

Short-Wave H.F. Chokes. 10-100 m., 10½d. each. High grade Pie Wound U.S.A. type, 1/9 each.

Lissen Dual Range Screened Coils. Medium and Long Waves, 2/9 each.

LEARNING MORSE

Premier Morse Practice Key on Bakelite Base and Brass Movement ... 3/3

General purpose Morse Key ... 5/10

Heavy Duty TX Key on Cast Base... 10/-

Bakelite Buzzers ... 2/-

Complete Kit of Parts for Valve Oscillator as described in W.V.V. "Learning Morse" ... 25/-

PREMIER 1940 HIGH FIDELITY AMPLIFIERS

Ideal for A.R.P. Alarm Systems

Complete Range of 7 High Fidelity P.A. Amplifiers for A.C. or A.C./D.C. Mains operation.

	Kit of Parts with Valves.	Completely Wired and Tested.
3-watt A.C. Amplifier	£2.14.0	£3.11.6
3-watt A.C./D.C. "	£3.0.0	£3.17.6
6-watt A.C. "	£6.16.6	£7.13.6
8-10-watt A.C./D.C. "	£6.11.6	£7.9.0
15-watt A.C. "	£7.13.9	£9.8.0

Black Crackle Steel Cabinet, 17/6 extra.

SHORT-WAVE CONDENSERS

Trolital insulation. Certified superior to ceramic. All-brass construction. Easily gauged.

15 m.mfd. ... 1/9	100 m.mfd. ... 2/3
25 m.mfd. ... 2/-	160 m.mfd. ... 2/6
40 m.mfd. ... 2/-	250 m.mfd. ... 2/11

NEW PREMIER 2-GANG S.W. CONDENSER, 2x.00015 mf. with integral slow motion, 7/6.

PREMIER'S OFFER OF PICK-UPS

Heads, will fit any tone arm 7/6
Pick-up with Arm and Volume Control, 2,000 ohms ... 12/6

Pick-up with Arm and Volume Control, 6,500 ohms ... 17/6

Rothermel Junior, Piezo Xtal Pick-up ... 24/6

Rothermel S.8, Piezo Xtal Pick-up ... 34/9

Rothermel Xtal Pick-up Head ... 19/6

Marconi K25, 1941 Model ... 25/8

PREMIER BATTERY CHARGERS

FOR A.C. MAINS

Westinghouse Rectification complete and ready for use

To Charge:

2 volts at ½ amp. ... 11/9

6 volts at ½ amp. ... 19/-

6 volts at 1 amp. ... 22/6

6 volts at 2 amps. ... 37/6

SPECIAL OFFER ROLA SPEAKERS

6 in. P.M.'s ... 15/-

8 in. P.M.'s ... 17/6

10 in. P.M.'s ... 22/6

G.12 Energised ... 63/-

All complete with O.P. transformer.

NEW PREMIER S.W. A.C. RECEIVER KIT

In response to many requests here is the New Premier 4-valve A.C. S.W. Kit. Circuit: Pen. H.F. Stage, Pen. Detector, Beam Output and F.W. Rec. 200-250 v. A.C. operation. Built-in Power Pack. Hum-free operation. For use with phones or P.M. Speaker. Complete Kit of Parts with drilled chassis, all components, Plug-in Coils covering 13-170 metres, 4 valves and full instructions and circuits £4.10.0. Completely wired and tested £5.10.0. Send for full details.

DE LUXE S.W. KITS

Complete to the last detail, including all Valves and coils, wiring diagrams and lucid instructions for building and working. Each Kit is supplied with a steel Chassis and Panel and use plug-in coils to tune from 13 to 170 metres.

1 Valve Short-Wave Receiver or Adapter Kit ... 20/-

1 Valve Short-Wave Superhet Converter Kit. Battery Operation ... 23/-

1 Valve Short-Wave A.C. Superhet Converter Kit ... 26/3

2 Valve Short-Wave Receiver Kit ... 29/-

3 Valve Short-Wave Screen Grid and Pentode Kit ... 68/-

PREMIER SHORT-WAVE KITS for OVERSEAS NEWS

Incorporating the Premier 3-Band S.W. Coil, 11-86 Metres without coil changing. Each Kit is complete with all components diagrams and 2-volt valves.

3-Band S.W. 1 Valve Kit ... 14/9

3-Band S.W. 2 Valve Kit ... 22/6

REPLACEMENT VALVES

FOR ALL SETS

Europa Mains Valves. 4 v. A.C. Types A.C./H.L., A.C./L., A.C./S.G., A.C./V.M.S.G., A.C./H.P., A.C./V.H.P., A.C.P., 5-pin types, all 5/6 each. A.C./H.P., A.C./V.H.P., 7-pin, 8/6. A.C./Pens, I.H., 8/6; A.C./P.X.4, 7/6; Oct. Freq. Changers, 8/6; Double Diode Triodes, 7/6; 3½-watt D.H. Triode, 12/6. 350 v. F.W. Rect., 5/6; 500 v., 7/6. 13 v. 2. amp. Gen. Purpose Triodes, 5/6; H.F. Pens. and Var.-Mu. H.F. Pen., Double Diode Triodes, Oct. Freq. Changers, 8/6 each. Full and Half-wave Rectifiers, 6/6 each.

PREMIER RADIO CO.

All Post Orders to: JUBILEE WORKS, 167 LOWER CLAPTON ROAD, LONDON, E.8 (Amherst 4723).

Callers to: Jubilee Works, or 169 Fleet Street, E.C.4 (Central 2833), or 50 High Street, Clapham, S.W.4 (Macaulay 2381).

WEBB'S IN WAR-TIME

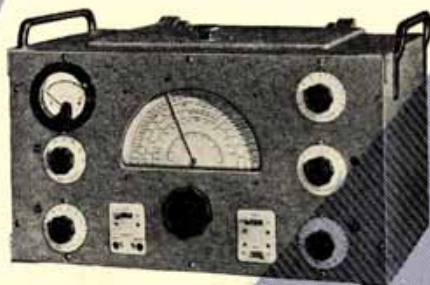

WHEN YOU ARE NEXT IN THE WEST END. PROVE TO YOURSELF THAT WEBB'S ARE STILL VERY MUCH ALIVE TO YOUR WANTS.

EVEN THOUGH YOU CANNOT BUY — COME IN AND SEE ONE OUTSTANDING PRODUCT OF WARTIME DEMAND — THE EDDYSTONE 358 COMMUNICATION RECEIVER.

SOME DAY THE WAR WILL END AND YOU MUST KNOW WHAT IS AVAILABLE FOR THAT NEW STATION.

ALL departments of His Majesty's Services have relied to a great extent on "Webb's" for the enormous number of essential components which have not been procurable elsewhere.

THE Radio Amateur and Experimenter have appreciated for years that they could procure any instrument or component necessary for development of high and ultra-high frequency equipment actually from "Webb's" stock.

THE War Office, Admiralty, Air Ministry are increasing their demands on our services, and despite the difficulties of trading, we are maintaining supplies in the interests of the great national effort. At the same time, we are not overlooking the immediate needs of our numerous friends who desire equipment for personal use.

ALTHOUGH supplies of many well-known products are strictly limited, we are still able to deliver most types of American valves, both transmitting and receiving — numerous American hard-to-substitute components and even a few communication receivers. Supplies of Headphones, telegraph keys, morse equipment, Eddystone components etc., are good. If it is humanly possible, we will never disappoint you.

WORLD-WIDE INFORMATION

WEBB'S RADIO

14, SOHO ST., OXFORD ST., LONDON, W.1.

Open 9.0 a.m to 6.0 p.m. Sats. 1 o'clock. Telephone: Gerrard 2089

